

Basler sprint



USER'S MANUAL FOR MONO CAMERAS

Document Number: AW000162

Version: 08 Language: 000 (English)

Release Date: 09 April 2009

For customers in the U.S.A.

This equipment has been tested and found to comply with the limits for a Class A digital device, pursuant to Part 15 of the FCC Rules. These limits are designed to provide reasonable protection against harmful interference when the equipment is operated in a commercial environment. This equipment generates, uses, and can radiate radio frequency energy and, if not installed and used in accordance with the instruction manual, may cause harmful interference to radio communications. Operation of this equipment in a residential area is likely to cause harmful interference in which case the user will be required to correct the interference at his own expense.

You are cautioned that any changes or modifications not expressly approved in this manual could void your authority to operate this equipment.

The shielded interface cable recommended in this manual must be used with this equipment in order to comply with the limits for a computing device pursuant to Subpart J of Part 15 of FCC Rules.

For customers in Canada

This apparatus complies with the Class A limits for radio noise emissions set out in Radio Interference Regulations.

Pour utilisateurs au Canada

Cet appareil est conforme aux normes Classe A pour bruits radioélectriques, spécifiées dans le Règlement sur le brouillage radioélectrique.

Life Support Applications

These products are not designed for use in life support appliances, devices, or systems where malfunction of these products can reasonably be expected to result in personal injury. Basler customers using or selling these products for use in such applications do so at their own risk and agree to fully indemnify Basler for any damages resulting from such improper use or sale.

Warranty Note

Do not open the housing of the camera. The warranty becomes void if the housing is opened.

All material in this publication is subject to change without notice and is copyright Basler Vision Technologies.

Contacting Basler Support Worldwide

Europe:

Basler AG
An der Strusbek 60 - 62
22926 Ahrensburg
Germany

Tel.: +49-4102-463-500
Fax.: +49-4102-463-599

bc.support.europe@baslerweb.com

Americas:

Basler, Inc.
855 Springdale Drive, Suite 160
Exton, PA 19341
U.S.A.

Tel.: +1-877-934-8472
Fax.: +1-610-280-7608

bc.support.usa@baslerweb.com

Asia:

Basler Asia Pte. Ltd
8 Boon Lay Way
03 - 03 Tradehub 21
Singapore 609964

Tel.: +65-6425-0472
Fax.: +65-6425-0473

bc.support.asia@baslerweb.com

www.baslerweb.com

Table of Contents

1	Specifications, Requirements, and Precautions	1
1.1	Document Applicability	1
1.2	General Specifications	2
1.2.1	Camera Models with 2k Pixels	2
1.2.2	Camera Models with 4k Pixels	3
1.2.3	Camera Models with 8k Pixels	4
1.3	Lens Adapters	5
1.3.1	Lens Adapters for 2k and 4k Cameras	5
1.3.2	Lens Adapters for 8k Cameras	5
1.3.2.1	Adapting with the UNIFOC 100/95/_/_V-Basler Helical Mount	6
1.3.2.2	Adapting with the M58 x 0.75/_/_V-Basler Lens Mount	8
1.4	Spectral Response	10
1.5	Mechanical Specifications	11
1.5.1	Camera Dimensions and Mounting Points for 2k and 4k Cameras	11
1.5.2	Sensor Positioning Accuracy for 2k and 4k Cameras	13
1.5.3	Sensor Line Location for 2k and 4k Cameras	14
1.5.4	F-mount Adapter Dimensions (2k and 4k Cameras)	15
1.5.5	Camera Dimensions and Mounting Points for 8k Cameras	15
1.5.6	Sensor Positioning Accuracy for 8k Cameras	17
1.5.7	Sensor Line Location for 8k Cameras	18
1.6	Environmental Requirements	19
1.6.1	Temperature and Humidity	19
1.6.2	Heat Dissipation	19
1.7	Precautions	20
2	Physical Interface	23
2.1	General Description of the Connections	24
2.2	Connector Pin Assignments and Numbering	25
2.2.1	Pin Assignments for the MDR Connectors	25
2.2.2	Pin Assignments for the 6-pin Micro-miniature Receptacle	27
2.2.3	Pin Numbering	27
2.3	Connector Types	28
2.3.1	26-pin Connectors	28
2.3.2	6-pin Connector	28
2.4	Cabling Requirements	29
2.4.1	Camera Link Cable	29
2.4.2	Power Cable	29
2.5	Camera Power	30
2.6	Camera Link Implementation	31
2.7	Input Signals	33
2.7.1	Serial to Camera	33
2.7.2	External Sync (ExSync)	33

2.8	Output Signals	34
2.8.1	Line Valid Bit	34
2.8.2	Data Valid Bit	34
2.8.3	Pixel Data Bits	34
2.8.4	Camera Link Pixel Clock	35
2.8.5	Serial to Frame Grabber	36
2.9	RS-644 Serial Communication	37
2.9.1	Making the Serial Connection	37
3	Line Acquisition Modes	39
3.1	Introduction	39
3.2	Single Line [Max 70 kHz] Acquisition Mode	40
3.3	Dual Line [Max 140 kHz] Acquisition Modes	41
3.4	Vertical Binning Acquisition Mode	49
3.5	Time Delayed Line Summing Acquisition Mode	51
3.6	Line Averaging Acquisition Mode	57
3.7	Time Delayed Line Averaging Acquisition Mode	58
3.8	Horizontal Binning	59
3.9	Recommendations for Using Time Delayed Line Summing or Time Delayed Line Averaging	61
3.9.1	Camera Operating Recommendations	61
3.9.2	System Design Recommendations	61
3.9.3	System Design Calculations	63
4	Exposure Start and Exposure Time Control	67
4.1	ExSync Controlled Operation	67
4.1.1	Basics of ExSync Controlled Operation	67
4.1.2	Selecting an ExSync Exposure Mode & Setting the Exposure Time	69
4.1.3	Guidelines When Using an ExSync Signal	69
4.2	Free Run	71
4.2.1	Basics of Free Run Controlled Operation	71
4.2.2	Selecting a Free Run Exposure Mode, Setting the Line Period, and Setting the Exposure Time	72
4.2.3	Guidelines When Using Free Run	73
4.3	Maximum Allowed Line Rate / Minimum Line Period	74
4.3.1	Max Segment AOI Pixels	77
4.3.2	Example of Calculating the Maximum Allowed Line Rate / Minimum Line Period	80
4.3.3	Increasing the Maximum Allowed Line Rate	81
4.3.4	Camera Settings for the Maximum Specified Line Rate	82

5	Video Data Output Modes	85
5.1	Overview	85
5.1.1	Setting the Video Data Output Mode	87
5.2	Video Data Output Mode Details	88
5.2.1	2 Tap Output Modes	88
5.2.1.1	Video Data Sequence for 2 Tap Output Modes	89
5.2.1.2	Line Valid Delays for 2 Tap Output Modes	93
5.2.2	4 Tap Output Modes	96
5.2.2.1	Video Data Sequence for 4 Tap Modes	97
5.2.2.2	Line Valid Delays for 4 Tap Output Modes	102
5.2.3	8 Tap 8 Bit Output Mode	105
5.2.3.1	Video Data Sequence for 8 Tap 8 Bit Mode	105
5.2.3.2	Line Valid Delays for 8 Tap Output Modes	112
6	Features	115
6.1	Gain and Offset	115
6.1.1	Gain	115
6.1.2	Offset	116
6.2	Area of Interest	118
6.2.1	Setting the AOI	120
6.3	Shading Correction	121
6.3.1	Enabling Shading Correction	122
6.3.2	Generating and Saving User Shading Correction Values	123
6.3.3	Activating a Shading Values File	128
6.3.4	Copying the Factory Shading Values into the User Shading Values File	129
6.3.5	Downloading a Shading Values File to Your PC	130
6.3.6	Uploading a Shading Values File to Your Camera	131
6.4	Test Images	132
6.4.1	Test Image One (Fixed Gradient)	133
6.4.2	Test Image Two (Moving Gradient)	134
6.4.3	Test Image Three (Uniform Black)	135
6.4.4	Test Image Four (Uniform Gray)	135
6.5	Line Stamp	136
6.5.1	Enabling and Setting the Line Stamp	140
6.6	Lookup Table	141
6.7	Imaging Sensor Temperature	144
6.8	Camera Power Undervoltage and Overvoltage Protection	145
6.9	Error Condition Detection	146
6.9.1	Imaging Sensor Overtemperature Condition Detected	146
6.9.2	Camera Power Overvoltage Condition Detected	147
6.10	Camera Status Checks	148
6.11	Camera Reset	148

6.12	Configuration Sets	149
6.12.1	Saving the Work Set to a User Set File	151
6.12.2	“Activating” a User Set File or the Factory Set File	152
6.12.3	Which Configuration Set File will Load at Startup or at Reset?	153
6.12.4	Downloading Configuration Set Files to Your PC	153
6.12.5	Uploading Configuration Set Files to Your Camera	154
7	Configuring the Camera	155
7.1	Configuring the Camera with the Camera Configuration Tool Plus (CCT+)	156
7.2	Configuring the Camera By Setting Registers	157
7.2.1	Inquiry Registers	158
7.2.1.1	Inquiry Register Details	158
	Vendor Information Inquiry	158
	Model Information Inquiry	158
	Product ID Inquiry	159
	Serial Number Inquiry	159
	Camera Version Inquiry	159
	Firmware Version Inquiry	160
	Camera Status Inquiry	161
	FPGA Status Inquiry	162
	Binary Command Protocol Status Inquiry	163
	Imaging Sensor Temperature Inquiry	163
7.2.2	Feature Control and Status Registers	164
7.2.2.1	“Raw” Value Fields vs. “Absolute” Value Fields	164
7.2.2.2	Feature Control and Status Register Details	166
	Camera Link Clock Speed CSR	166
	Video Data Output Mode CSR	166
	Line Acquisition Mode CSR	167
	Horizontal Binning CSR	168
	Exposure Time Control Mode CSR	168
	Exposure Time CSR	169
	Line Period CSR	171
	Gain CSR	173
	Offset CSR	174
	Area of Interest Starting Pixel CSR	176
	Area of Interest Length CSR	177
	Shading Mode CSR	178
	Shading Value Generate CSR	178
	Test Image Mode CSR	179
	Line Stamp Mode CSR	180
	Line Stamp Low Pixel Limit CSR	181
	Line Stamp High Pixel Threshold CSR	182
	Lookup Table Mode CSR	183
	Lookup Table Index CSR	184
	Lookup Table Value CSR	185
	Camera Reset CSR	186
	Serial Communication CSR	187

7.2.3	Bulk Data and the Bulk Data Control and Status Registers	188
7.2.3.1	Using the Configuration Set Bulk Data CSR	189
7.2.3.2	Using the Shading Values Bulk Data CSR	190
7.2.3.3	General Procedures for Working with Bulk Data CSRs.	191
7.2.3.4	Bulk Data Control and Status Register Details	194
	Configuration Set CSR	194
	Shading Values CSR	195
7.3	Using Binary Read/Write Commands	196
7.3.1	The Binary Read/Write Command Protocol	197
7.3.1.1	Error Checking and Responses.	200
7.3.2	Basic Read/Write Command Explanations	201
7.3.2.1	Read Command	201
7.3.2.2	Write Command.	202
7.3.2.3	Calculating the Block Check Character	203
7.4	Binary Command Sample Code	204
8	Troubleshooting and Support	205
8.1	Tech Support Resources	205
8.2	Obtaining an RMA Number.	205
8.3	Fault Finding Using the Camera LED.	206
8.4	Troubleshooting Charts	208
8.4.1	No Image	209
8.4.2	Poor Quality Image	211
8.4.3	Interfacing	212
8.4.4	RS-644 Serial Communication.	213
8.4.5	Before Calling Basler Technical Support	214
	Revision History	217
	Feedback	221
	Index.	223

1 Specifications, Requirements, and Precautions

This section lists the camera models covered by the manual. It provides the general specifications for each model and outlines the basic requirements for using the cameras.

This section also includes specific precautions that you should keep in mind when using the cameras. We strongly recommend that you read and follow the precautions.

1.1 Document Applicability

This User's Manual applies to sprint mono cameras with a camera version ID number of 04.

Cameras with a lower or a higher ID number may have fewer features or have more features than described in this manual. Features on cameras with a lower or a higher ID number may not operate exactly as described in this manual.

An easy way to see the camera version ID number for a sprint camera is by using the CCT+. To see the camera version ID number:

1. Double click the CCT+ icon on your desktop or click **Start > All Programs > Basler Vision Technologies > CCT+ > CCT+**. The CCT+ window will open and the software will connect to your camera.
2. Scroll down until you find the "Camera Information" group heading. If there is a plus sign beside the Camera Information group heading, click on the plus sign to show the list of parameters in the group.
3. Find the parameter called "Camera Version." As shown in Figure 1-1, the last two numbers of this parameter are the camera version ID number.

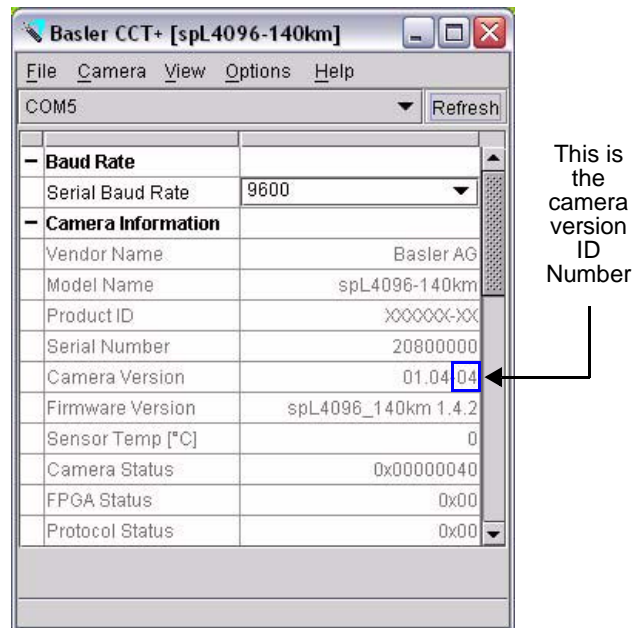

Fig. 1: CCT+ Window

You can also access the camera version ID number by using binary commands to read the Camera Version Inquiry register. (See Section 7.2.1 on page 158 for an explanation of inquiry registers and Section 7.3 on page 196 for information on using binary commands.)

1.2 General Specifications

1.2.1 Camera Models with 2k Pixels

Specification	spL2048-39km	spL2048-70km	spL2048-140km
Sensor Size	2 lines - 2048 pixels per line		
Sensor Type	Monochrome linear CMOS		
Pixel Size	10 μm x 10 μm		
Camera Link Clock Speed	40 MHz	40 MHz or 80 MHz (switchable)	
Maximum Line Rate	38.6 kHz	70 kHz	140 kHz (in dual line acquisition mode)
Minimum Line Rate	1 kHz		
Data Output Type	Camera Link base configuration		Camera Link medium/full configuration
Data Output Modes	2 tap - 8, 10, or 12 bit		2 tap - 8, 10, or 12 bit 4 tap - 8, 10, or 12 bit 8 tap - 8 bit
Synchronization	Via external trigger signal or free run		
Exposure Control	Edge controlled, level controlled, or programmable		
Gain and Offset	Programmable via a serial link		
Connectors	One, 6-pin, Hirose micro-miniature receptacle One, 26-pin, female MDR connectors		One, 6-pin, Hirose micro-miniature receptacle Two, 26-pin, female MDR connector
Power Requirements	+12 VDC ($\pm 10\%$) Max 5.0 W @ 12 VDC when set for the single line acquisition mode Max 6.0 W @ 12 VDC when set for all other line acquisition modes		
Lens Adapter	F-mount, M42, C-Mount (see Section 1.3 on page 5)		
Housing Size (L x W x H)	48.0 mm x 87.0 mm x 62.0 mm (without lens adapter or connectors) 84.9 mm x 87.0 mm x 62.0 mm (with F-mount adapter and connectors)		
Weight	~ 360 g (without lens adapter)		

Table 1: General Specifications for 2k Cameras

For information about the combinations of parameter settings for achieving the maximum specified line rates, see Table 10 on [page 83](#).

1.2.2 Camera Models with 4k Pixels

Specification	spL4096-20km	spL4096-39km	spL4096-70 km	spL4096-140km
Sensor Size	2 lines - 4096 pixels per line			
Sensor Type	Monochrome linear CMOS			
Pixel Size	10 μm x 10 μm			
Camera Link Clock Speed	40 MHz	40 MHz or 80 MHz (switchable)		
Maximum Line Rate	19.4 kHz	38.6 kHz	70 kHz	140 kHz (in dual line acquisition mode)
Minimum Line Rate	1 kHz			
Data Output Type	Camera Link base config.	Camera Link medium/full configuration		
Data Output Modes	2 tap - 8, 10, or 12 bit	2 tap - 8, 10, or 12 bit 4 tap - 8, 10, or 12 bit	2 tap - 8, 10, or 12 bit 4 tap - 8, 10, or 12 bit 8 tap - 8 bit	
Synchronization	Via external trigger signal or free run			
Exposure Control	Edge controlled, level controlled, or programmable			
Gain and Offset	Programmable via a serial link			
Connectors	One, 6-pin, Hirose micro-miniature receptacle One, 26-pin, female MDR connector	One, 6-pin, Hirose micro-miniature receptacle Two, 26-pin, female MDR connectors		
Power Requirements	+12 VDC (\pm 10%) Max 7.0 W @ 12 VDC when set for the single line acquisition mode Max 10.0 W @ 12 VDC when set for all other line acquisition modes			
Lens Adapter	F-mount, M42			
Housing Size (L x W x H)	48.0 mm x 87.0 mm x 62.0 mm (without lens adapter or connectors) 84.9 mm x 87.0 mm x 62.0 mm (with F-mount adapter and connectors)			
Weight	~ 360 g (without lens adapter)			

Table 2: General Specifications for 4k Cameras

For information about the combinations of parameter settings for achieving the maximum specified line rates, see Table 10 on [page 83](#).

1.2.3 Camera Models with 8k Pixels

Specification	spL8192-20km	spL8192-39km	spL8192-70km
Sensor Size	2 lines - 8192 pixels per line		
Sensor Type	Monochrome linear CMOS		
Pixel Size	10 μm x 10 μm		
Camera Link Clock Speed	40 MHz	40 MHz or 80 MHz (switchable)	
Maximum Line Rate	19.4 kHz	38.6 kHz	70 kHz
Minimum Line Rate	1 kHz		
Data Output Type	Camera Link medium config.	Camera Link medium/full configuration	
Data Output Modes	2 tap - 8, 10, or 12 bit 4 tap - 8, 10, or 12 bit	2 tap - 8, 10, or 12 bit 4 tap - 8, 10, or 12 bit 8 tap - 8 bit	
Synchronization	Via external trigger signal or free run		
Exposure Control	Edge controlled, level controlled, or programmable		
Gain and Offset	Programmable via a serial link		
Connectors	One, 6-pin, Hirose micro-miniature receptacle Two, 26-pin, female MDR connectors		
Power Requirements	+12 VDC ($\pm 10\%$) Max 10.0 W @ 12 VDC when set for the single line acquisition mode Max 13.5 W @ 12 VDC when set for all other line acquisition modes		
Lens Adapters	Sets of optical components including a helical mount or a lens mount with V-Basler interface		
Housing Size (L x W x H)	49.0 mm x 92.0 mm x 102.0 mm (without optical components or connectors) 53.5 mm x 92.0 mm x 102.0 mm (without optical components, with connectors)		
Weight	~ 580 g (without optical components) ~ 1480 g (with UNIFOC 100/95/_/_V-Basler helical mount) ~ 780 g (with M58 x 0.75/_/_V-Basler lens mount)		

Table 3: General Specifications for 8k Cameras

For information about the combinations of parameter settings for achieving the maximum specified line rates, see Table 10 on [page 83](#).

1.3 Lens Adapters

1.3.1 Lens Adapters for 2k and 4k Cameras

An F-mount lens adapter is standard for all cameras with 2048 pixels per line (2k cameras) and with 4096 pixels per line (4k cameras).

For 4k cameras an optional M42 lens adapter is also available.

For 2k cameras, an optional M42 lens adapter and an optional C-mount lens adapter are also available.

For cameras with 8192 pixels per line (8k cameras), a helical mount or a lens mount with V-Basler interface are required as adapters. For more information about the optical components and how to obtain them, see Section 1.3.2.1 on [page 6](#) and Section 1.3.2.2 on [page 8](#).



Note

When a C-mount lens is used with a 2k camera, the image produced by the pixels near the ends of the sensor lines may appear degraded. This effect is caused by using a lens with a relatively small diameter compared to the length of the sensor lines. Typically, use of a C-mount lens on 2k cameras is appropriate in applications where the image data from pixels near the ends of each line can be discarded.

1.3.2 Lens Adapters for 8k Cameras

Basler sprint 8k cameras feature specific V-Basler interfaces which allow connecting to Basler-specific adapters. Two Basler-specific adapters are available:

- UNIFOC 100/95_/_V-Basler helical mount, a Basler-specific modification of UNIFOC 100/95 of Schneider-Kreuznach
- M58 x 0.75_/_V-Basler lens mount, a Basler-specific conical tube.

The choice of a Basler-specific adapter, further optical components, and lens depends e.g. on the magnification and the working distance required by your application. Contact Basler technical support for selecting the Basler-specific adapter, further optical components, and the lens that will best suit your requirements.

For information about obtaining the UNIFOC 100/95_/_V-Basler helical mount or the M58 x 0.75_/_V-Basler lens mount, contact Basler technical support.

For information about additional optical components and how to obtain them, visit e.g. the Schneider-Kreuznach website: www.schneiderkreuznach.com.

The following sections illustrate how the Basler sprint 8k cameras connect to Basler-specific adapters and further optical components. As examples, components by Schneider-Kreuznach are considered.

1.3.2.1 Adapting with the UNIFOC 100/95/_/V-Basler Helical Mount

The following example illustrates the use of the UNIFOC 100/95/_/V-Basler helical mount, connected to a Makro-Symmar HM 5.6/120-0058 lens by Schneider-Kreuznach. The UNIFOC 100/95/_/V-Basler helical mount includes a sliding insert that allows adjusting the extension over a range of ca. 100 mm.

The assembly shown in [Figure 2](#) as an example, is adjusted for a magnification of 1:1. The overall length of the adjusted assembly including the camera (with connectors) is ca. 306.7 mm. Taking account of the working distance of the Makro-Symmar HM 5.6/120-0058 lens of ca. 212 mm, the overall distance between the imaged object and the camera's back (with connectors) is ca. 518.7 mm.

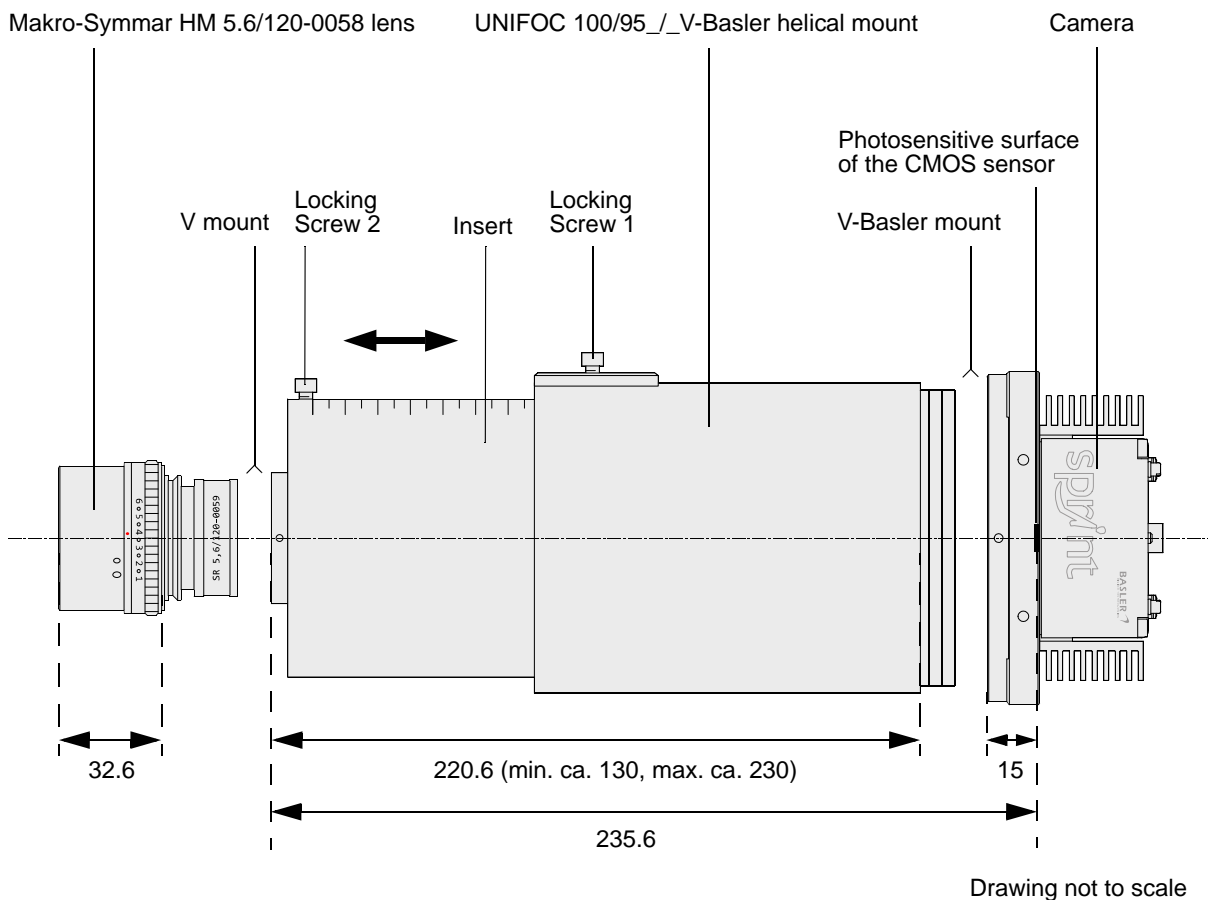

Fig. 2: Using the UNIFOC 100/05/_/V-Basler Helical Mount (Distances in mm)

Attaching the UNIFOC 100/95_/_ V-Basler Helical Mount to the Camera

Use the four M3 setscrews supplied with the camera to attach the helical mount to the camera. See Figure 9 for information where to place the M3 screws.



Note

When screwing in the M3 screws make sure to never exceed a torque of 0.1 Nm. If the torque is exceeded, the helical mount can be damaged and may no longer be light-proof.

Adjusting the Assembly of Optical Components

For a reproduction ratio of 1:1, the Makro-Symmar HM 5.6/120-0058 lens requires a distance of 235.6 mm between its flange and the CMOS sensor. The distance to the CMOS sensor is accounted for by adding the following partial distances:

- 15 mm: distance between the CMOS sensor and the flange of the camera's V-Basler mount
 - ca. 130 mm: minimum extension of the helical mount,
 - 90.6 mm: added extension of the helical mount by partly sliding out the insert.
1. Coarsely focus on an object placed in front of the lens at working distance (212 mm), by sliding the insert of the helical mount in its correct position. Lock the insert by screwing in locking screw 1.
 2. Fine focus the lens on the object by turning the lens to employ the helical threads. After having attained the optimum focus, screw in locking screw 2.

1.3.2.2 Adapting with the M58 x 0.75/_/_V-Basler Lens Mount

The following example illustrates the use of the M58 x 0.75/_/_V-Basler lens mount, connected to an assembly of further optical components, including a UNIFOC 76 helical mount, an M39 x 26 tpi adapter, and an Apo-Componon 4.5/90 lens by Schneider-Kreuznach. The UNIFOC 76 helical mount allows adjusting its extension over a range of 25.7 mm.

The assembly shown in [Figure 3](#) as an example, is adjusted for a magnification of 1:0.3. The overall length of the adjusted assemblage including the camera (with connectors) is ca. 185.1 mm. Taking account of the working distance of the Apo-Componon 4.5/90 lens of ca. 362 mm, the overall distance between the imaged object and the camera's back (with connectors) is ca. 547.1 mm.

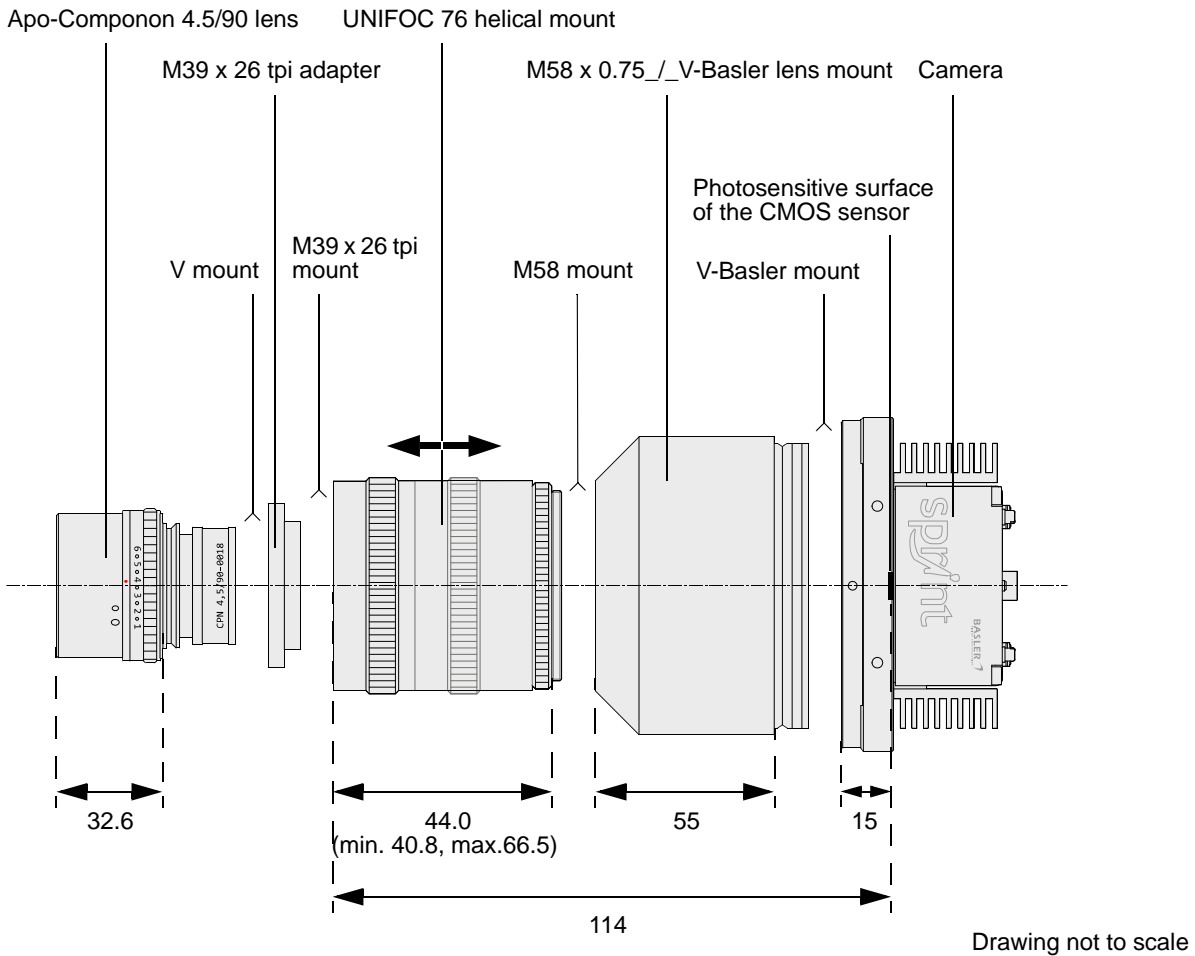

Fig. 3: Using the M58 x 0.75/_/_V-Basler Lens Mount (Distances in mm)

Adjusting the Assembly of Optical Components

For a magnification of 1:0.3, the Apo-Componon 4.5/90 lens requires a distance of 114 mm between its flange and the CMOS sensor. The distance to the CMOS sensor is accounted for by adding the following partial distances:

- 15 mm: distance between the CMOS sensor and the flange of the camera's V-Basler mount
- 55 mm: extension of the M58 x 0.75_/_V-Basler lens mount
- 44 mm: extension of the UNIFOC 76 helical mount

The M39 x 26 tpi adapter fits completely inside the UNIFOC 76 helical mount

1. Focus the lens on an object placed in front of the lens at the working distance of ca. 362 mm. Use the helical mount for focussing.

1.4 Spectral Response

The following graph shows the spectral response for monochrome cameras.



Note

The spectral response curves exclude lens characteristics and light source characteristics.

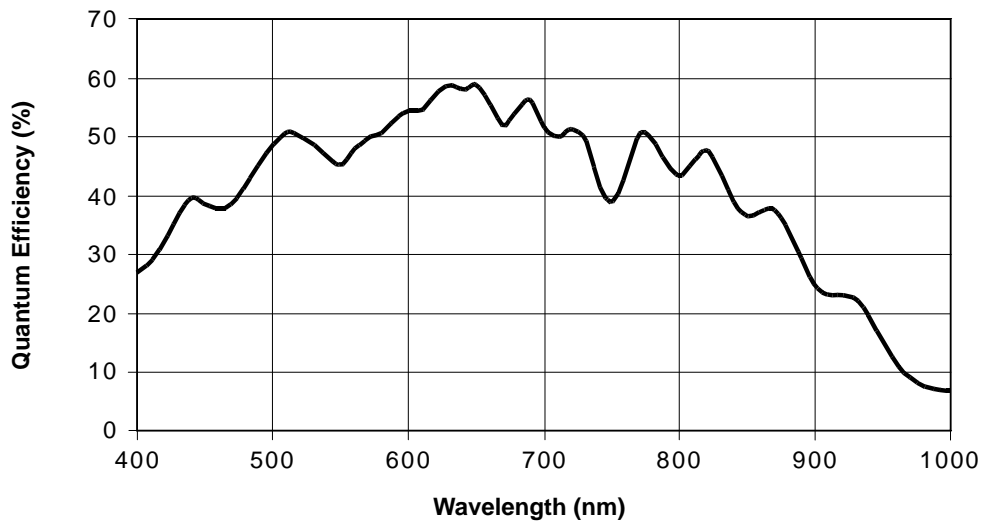

Fig. 4: Camera Spectral Response

1.5 Mechanical Specifications

1.5.1 Camera Dimensions and Mounting Points for 2k and 4k Cameras

The cameras are manufactured with high precision. Planar, parallel, and angular sides guarantee precise mounting with high repeatability.

The camera's dimensions in millimeters are as shown in Figure 5 on [page 12](#).

Camera housings are equipped with four mounting holes on the front and two mounting holes on the sides as shown in the drawings

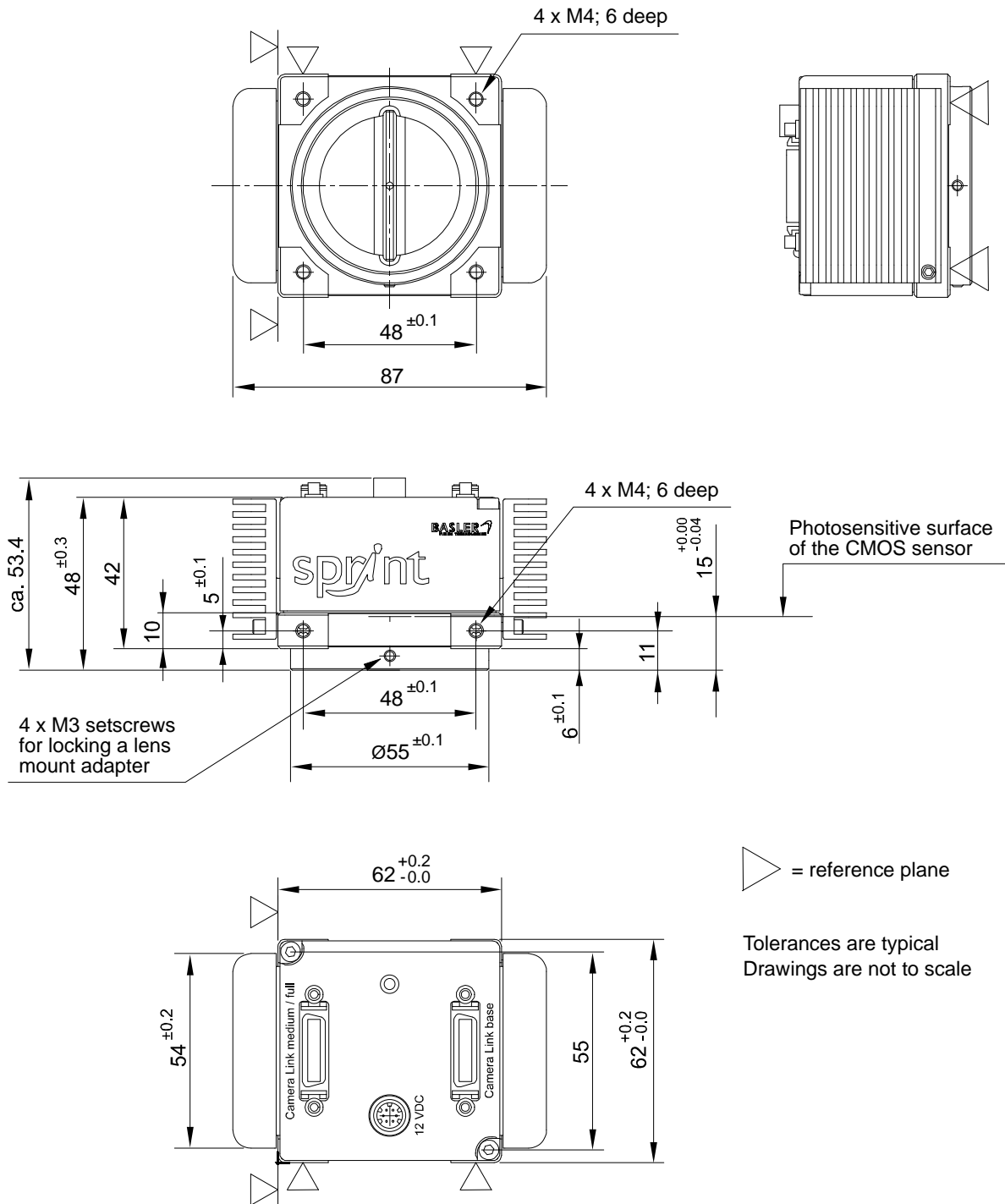

Fig. 5: Mechanical Dimensions (in mm; 2k and 4k Cameras)

1.5.2 Sensor Positioning Accuracy for 2k and 4k Cameras

The sensor positioning accuracy is as shown in the drawings below.

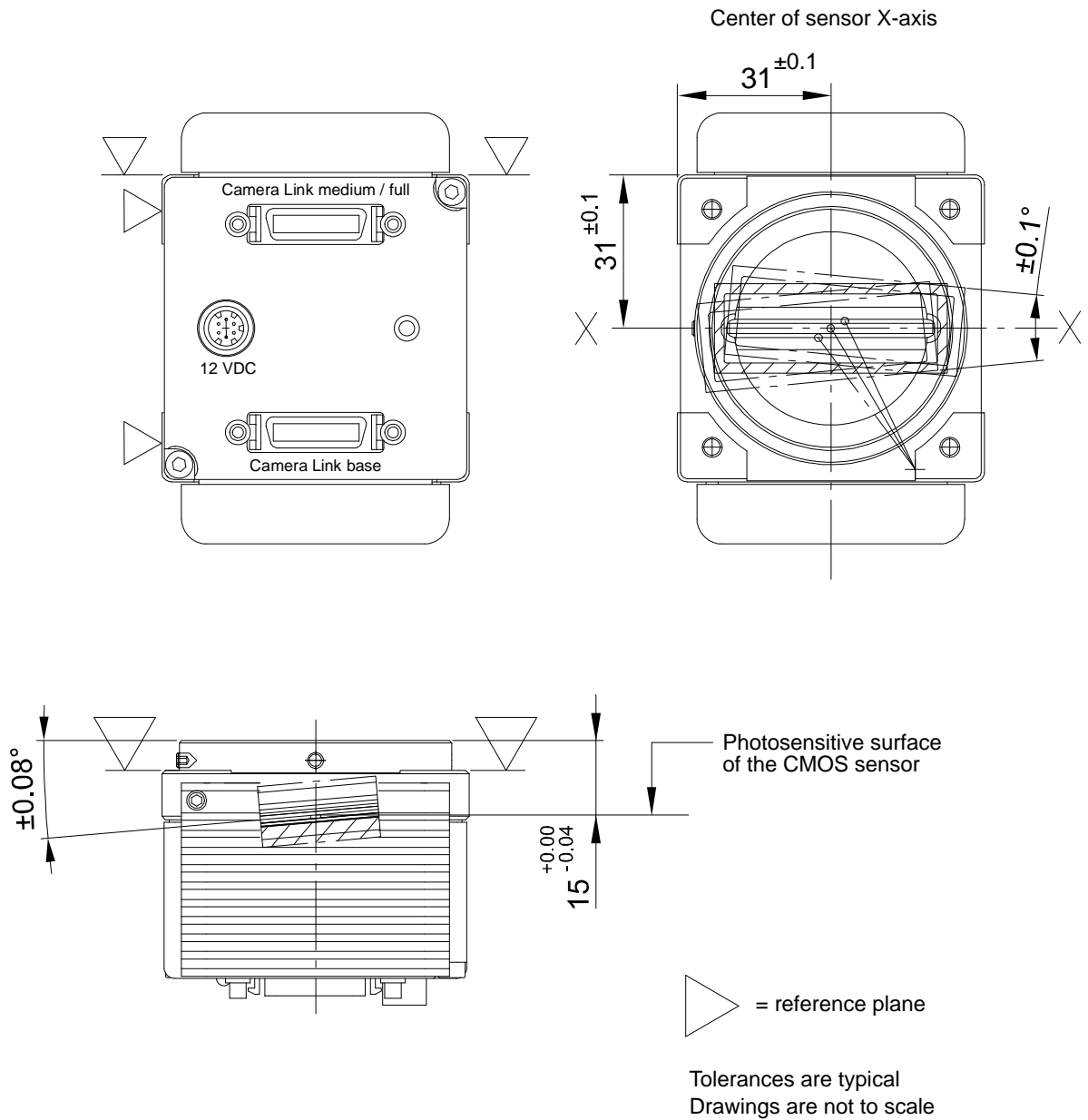

Fig. 6: Sensor Positioning Accuracy (in mm unless otherwise noted; 2k and 4k Cameras)

1.5.3 Sensor Line Location for 2k and 4k Cameras

The location of the lines on the sensor chip is as shown in the drawing below.

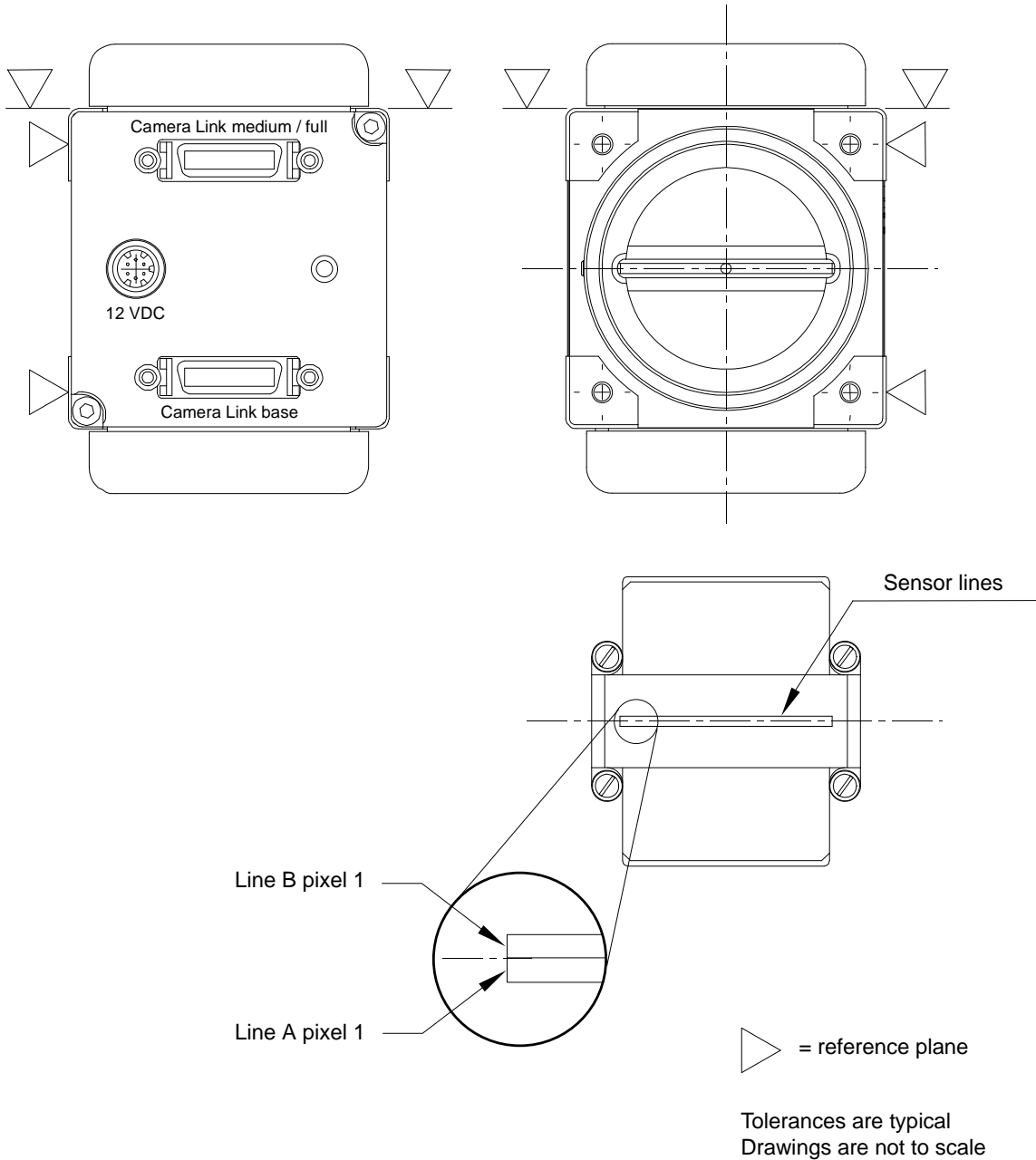
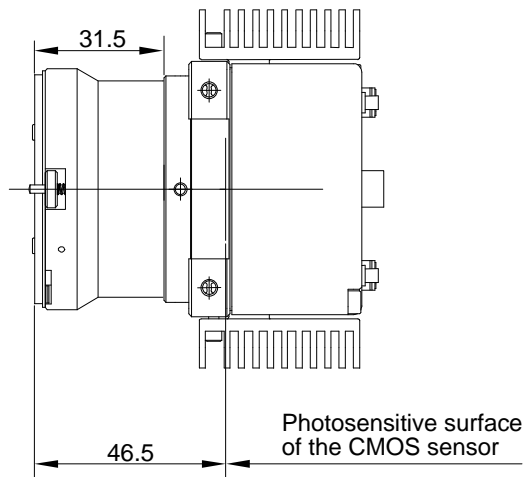

Fig. 7: Sensor Line Location (2k and 4k Cameras)

1.5.4 F-mount Adapter Dimensions (2k and 4k Cameras)



Drawing is not to scale

Fig. 8: Camera with F-mount Adapter Attached (in mm; 2k and 4k Cameras)

1.5.5 Camera Dimensions and Mounting Points for 8k Cameras

The cameras are manufactured with high precision. Planar, parallel, and angular sides guarantee precise mounting with high repeatability.

The camera's dimensions in millimeters are as shown in Figure 5 on [page 12](#).

Camera housings are equipped with four mounting holes on the front and two mounting holes on the sides as shown in the drawings

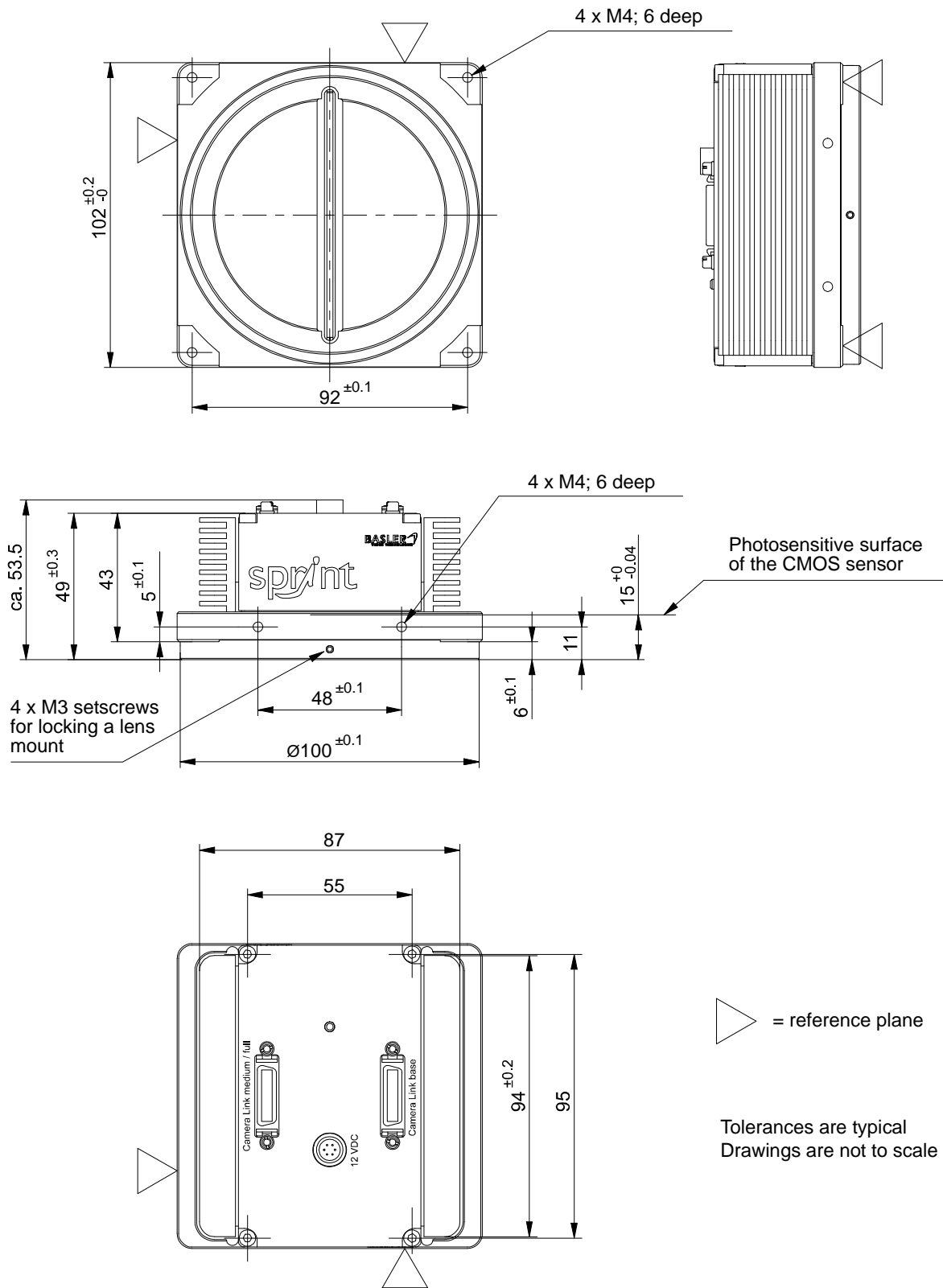

Fig. 9: Mechanical Dimensions (in mm; 8k Cameras)

1.5.6 Sensor Positioning Accuracy for 8k Cameras

The sensor positioning accuracy is as shown in the drawings below.

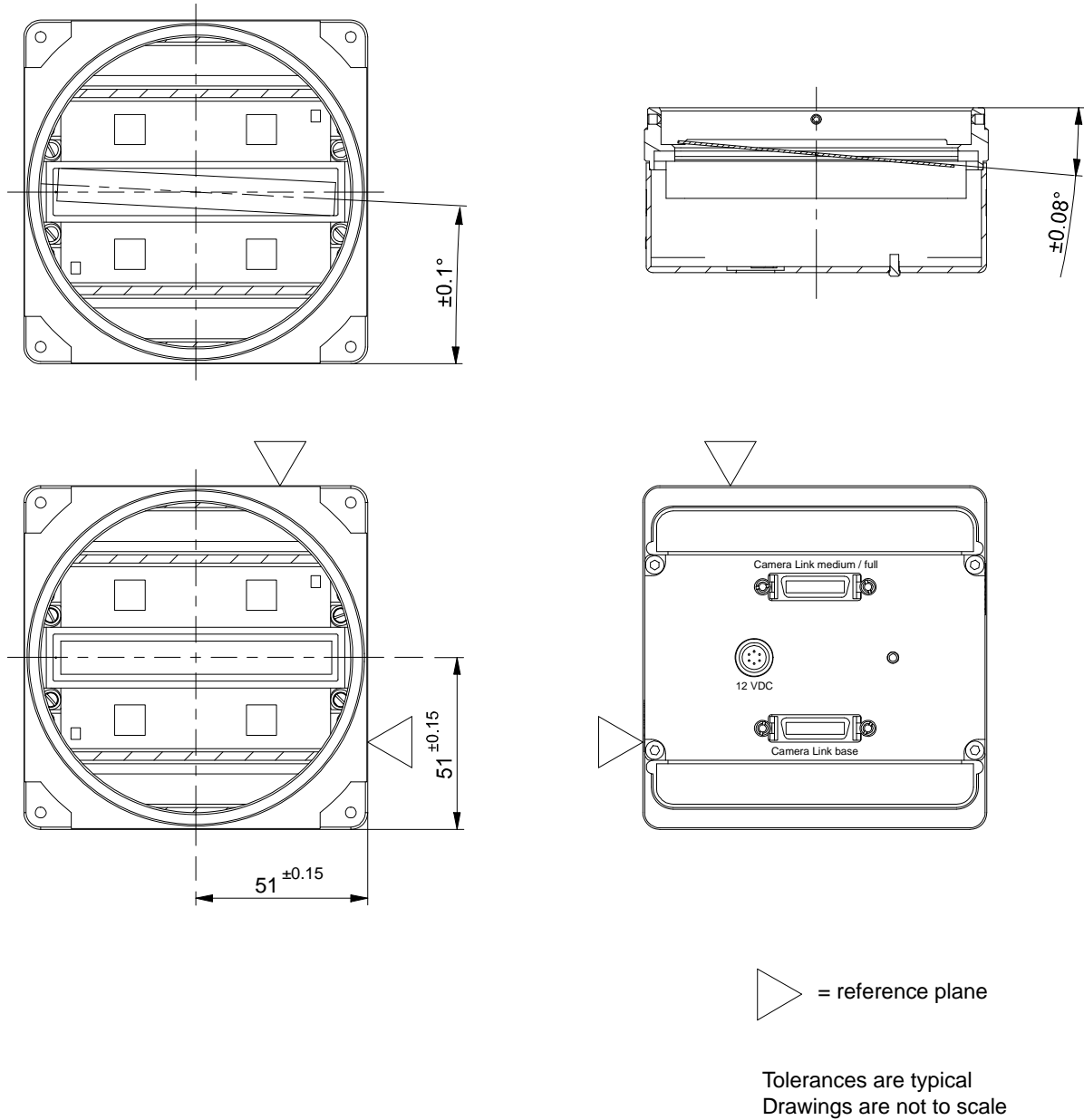

Fig. 10: Sensor Positioning Accuracy (in mm unless otherwise noted; 8k Cameras)

1.5.7 Sensor Line Location for 8k Cameras

The location of the lines on the sensor chip is as shown in the drawing below.

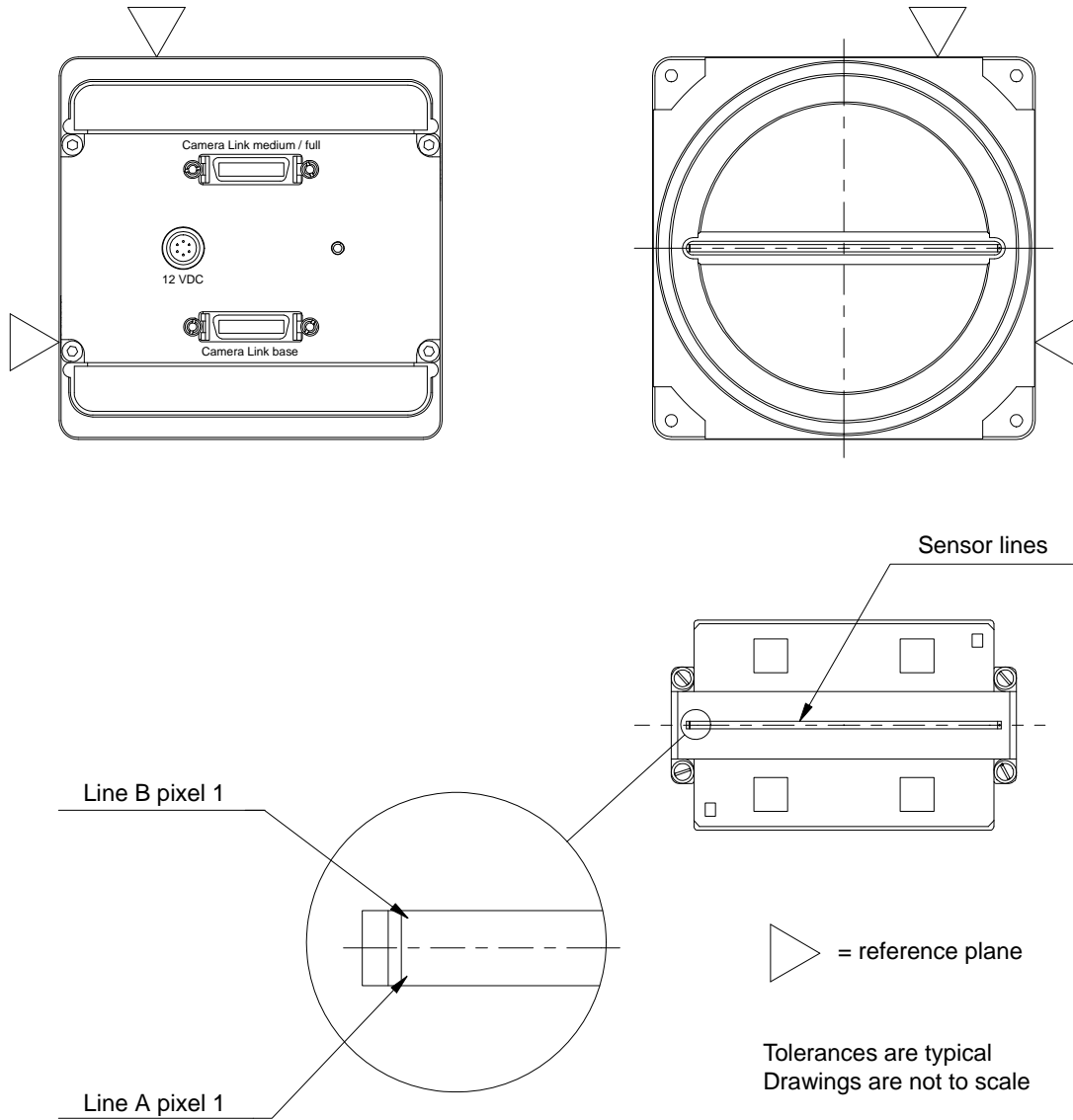

Fig. 11: Sensor Line Location (8k Cameras)

1.6 Environmental Requirements

1.6.1 Temperature and Humidity

Housing temperature during operation:	0° C ... +50° C (+32° F ... +122° F)
Humidity during operation:	20% ... 80%, relative, non-condensing
Storage temperature:	-20° C ... +80° C (-4° F ... +176° F)
Storage humidity:	5% ... 95%, relative, non-condensing

1.6.2 Heat Dissipation

You must provide sufficient heat dissipation to maintain the temperature of the camera housing at 50° C or less. Since each installation is unique, Basler does not supply a strictly required technique for proper heat dissipation. Instead, we provide the following general guidelines.

- In all cases, you should monitor the temperature of the camera housing and make sure that the temperature does not exceed 50° C. Keep in mind that the camera will gradually become warmer during the first 1.5 hours of operation. After 1.5 hours, the housing temperature should stabilize and no longer increase.
- If your camera is mounted on a substantial metal component in your system, this may provide sufficient heat dissipation.
- Use of a fan to provide air flow over the camera is an extremely efficient method of heat dissipation. Using a fan to provide air flow over the camera's heat sinks provides the best heat dissipation.

The camera includes an overtemperature protection function that will switch off the imaging sensor circuitry if the temperature of the sensor is too high. See Section 6.9.1 on [page 146](#) for more information.

The camera also includes an internal temperature sensor that lets you monitor the temperature of the imaging sensor. See Section 6.7 on [page 144](#) for more information.

**Note**

Keeping the camera cool will give you the best signal-to-noise ratio. When the camera operates hot, the signal-to-noise ratio is reduced.

1.7 Precautions



CAUTION

Applying Incorrect Camera Power Can Damage the Camera

The nominal voltage for the camera power is 12 VDC ($\pm 10\%$). We do not recommend applying a voltage less than 10.8 VDC or greater than 13.2 VDC.

The camera has camera power undervoltage protection that is triggered if the voltage drops below 10.5 VDC. It also has camera power overvoltage protection up to 25 VDC. See Section 6.8 on [page 145](#) for more detailed information about camera power undervoltage and overvoltage protection.

Applying a camera power voltage greater than 25 VDC can seriously damage the camera.



CAUTION

Making or Breaking Connections Incorrectly Can Damage the Camera

Be sure that all power to your camera and to your host PC is switched off before you make or break connections to the camera. Making or breaking connections when power is on can result in damage to the camera or to the frame grabber.

If you can't switch off the power, be sure that the camera power plug is the last connector that you plug into the camera when making connections and the first connector that you unplug from the camera when breaking connections.



CAUTION

An Incorrect Plug Can Damage the Camera's 6-pin Connector

The plug on the cable that you attach to the camera's 6-pin connector must be a plug for 6 pins. Using a plug designed for a smaller or a larger number of pins can damage the pins in the camera's 6-pin connector.

**CAUTION****Avoid Dust on the Sensor**

The 2k and 4k cameras are shipped with caps on the lens mounts. To avoid collecting dust on the camera's sensor, make sure that the cap is always in place when there is no lens mounted on the camera.

Whenever you remove the cap to mount a lens, be sure that the lens mount is pointing down.

The 8k cameras are shipped with protective self-adhesive foils covering the lens mounts. To avoid collecting dust on the camera's sensor, make sure that the foil is always in place when there is no lens mounted on the camera.

Whenever you remove the foil to mount a lens, be sure that the lens mount is pointing down.

Warranty Precautions

To ensure that your warranty remains in force:

Do not remove the camera's serial number label

If the label is removed and the serial number can't be read from the camera's registers, the warranty is void.

Do not open the camera housing

Do not open the housing. Touching internal components may damage them.

Keep foreign matter outside of the camera

Be careful not to allow liquid, flammable, or metallic material inside of the camera housing. If operated with any foreign matter inside, the camera may fail or cause a fire.

Electromagnetic fields

Do not operate the camera in the vicinity of strong electromagnetic fields. Avoid electrostatic charging.

Transportation

Transport the camera in its original packaging only. Do not discard the packaging.

Cleaning

Avoid cleaning the surface of the camera's sensor if possible. If you must clean it, use a soft, lint free cloth dampened with a small quantity of high quality window cleaner. Because electrostatic discharge can damage the sensor, you must use a cloth that will not generate static during cleaning (cotton is a good choice).

To clean the surface of the camera housing, use a soft, dry cloth. To remove severe stains, use a soft cloth dampened with a small quantity of neutral detergent, then wipe dry.

Do not use solvents or thinners to clean the housing; they can damage the surface finish.

Read the manual

Read the manual carefully before using the camera!

2 Physical Interface

This section describes the camera's physical interface. It includes details about connections, input signals, and output signals. It also includes a description of how the Camera Link standard is implemented in the camera.



CAUTION

Applying Incorrect Input Power Can Damage the Camera

The camera's nominal input power voltage is 12 VDC ($\pm 10\%$). We do not recommend applying an input voltage less than 10.8 VDC or greater than 13.2 VDC.

The camera has undervoltage protection that is triggered if the input voltage drops below 10.5 VDC. It also has input overvoltage protection up to 25 VDC. See Section 6.8 on [page 145](#) for more detailed information about input undervoltage and overvoltage protection.

Applying an input power voltage greater than 25 VDC can seriously damage the camera.



CAUTION

Making or Breaking Connections Incorrectly Can Damage the Camera

Be sure that all power to your camera and to your host PC is switched off before you make or break connections to the camera. Making or breaking connections when power is on can result in damage to the camera or to the frame grabber.

If you can't switch off the power, be sure that the input power plug is the last connector that you plug into the camera when making connections and the first connector that you unplug from the camera when breaking connections.

2.1 General Description of the Connections

The camera is interfaced to external circuitry via connectors located on the back of the housing:

- one or two, 26-pin, 0.050 inch Mini D Ribbon (MDR) female connectors used to transfer pixel data, control data, and configuration data. The number of MDR connectors present on the camera varies by camera model as shown in Table 4.
- a 6-pin, micro-miniature, push-pull receptacle used to provide power to the camera.

An LED located on the back of the camera is used to indicate power present and to display the camera's status. Figure 12 shows the connectors and the LED for 2k and 4k cameras. The connectors and the LED for 8k cameras are analogous.

Model	MDR Connectors	Camera Link Configuration
spL2048-39km, spL2048-70km, spL4096-20km	MDR Conn. 1 only	Base
spL2048-140km, spL4096-39km, spL4096-70km, spL4096-140km, spL8192-20km, spL8192-39km, spL8192-70km	MDR Conn. 1 and MDR Conn. 2	Medium/full

Table 4: MDR Connectors by Camera Model

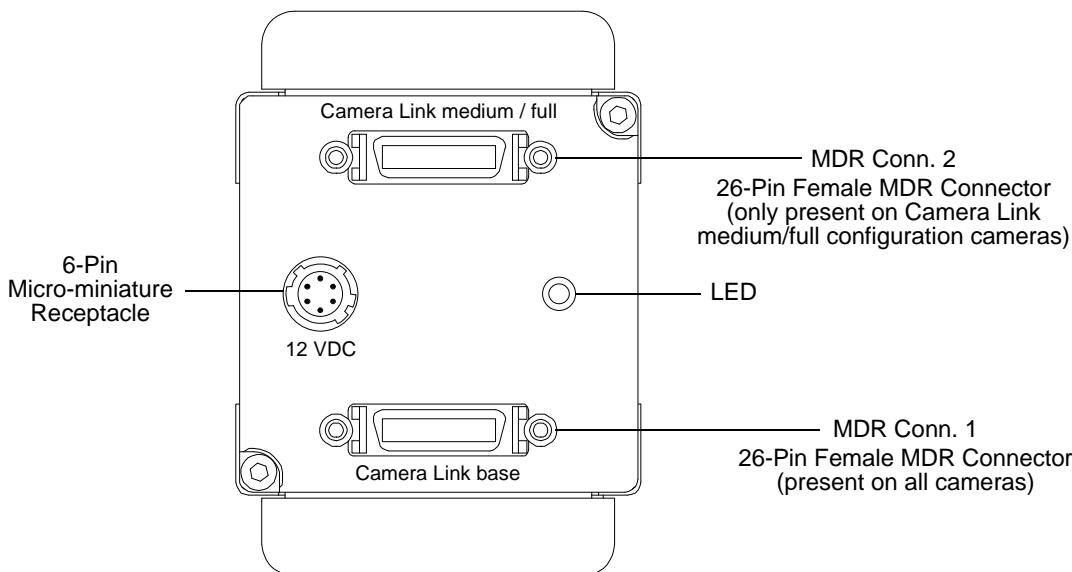

Fig. 12: Connectors and LED (2k and 4k cameras; 8k cameras are analogous)

2.2 Connector Pin Assignments and Numbering

2.2.1 Pin Assignments for the MDR Connectors

The pin assignments for MDR Connector 1 (see Figure 12 on [page 24](#)) are shown in Table 5. The pin assignments for MDR connector 2 are shown in Table 6.

Pin Number	Signal Name	Direction	Level	Function
1, 13, 14, 26 ¹	Gnd	Input	Ground	Ground for the inner shield of the cable
2	X0-	Output	Camera Link LVDS	Data from the Camera Link transmitter
15	X0+			
3	X1-	Output	Camera Link LVDS	Data from the Camera Link transmitter
16	X1+			
4	X2-	Output	Camera Link LVDS	Data from the Camera Link transmitter
17	X2+			
6	X3-	Output	Camera Link LVDS	Data from the Camera Link transmitter
19	X3+			
5	XClk-	Output	Camera Link LVDS	Transmit clock from the Camera Link transmitter
18	XClk+			
7	SerTC+	Input	RS-644 LVDS	Serial communication data receive (SerTC = "serial to camera")
20	SerTC-			
8	SerTFG-	Output	RS-644 LVDS	Serial communication data transmit (SerTFG = "serial to frame grabber")
21	SerTFG+			
9	CC1-	Input	RS-644 LVDS	ExSync (external trigger)
22	CC1+			
10	CC2+	Input	RS-644 LVDS	Not used
23	CC2-			
11	CC3-	Input	RS-644 LVDS	Not used
24	CC3+			
12	CC4+	Input	RS-644 LVDS	Not used
25	CC4-			

Table 5: Pin Assignments for MDR Connector 1

¹ Pins 1, 13, 14, and 26 are all tied to ground inside of the camera.

Pin Number	Signal Name	Direction	Level	Function
1, 13, 14, 26 ¹	Gnd	Input	Ground	Ground for the inner shield of the cable
2	Y0-	Output	Camera Link LVDS	Data from the Camera Link transmitter
15	Y0+			
3	Y1-	Output	Camera Link LVDS	Data from the Camera Link transmitter
16	Y1+			
4	Y2-	Output	Camera Link LVDS	Data from the Camera Link transmitter
17	Y2+			
6	Y3-	Output	Camera Link LVDS	Data from the Camera Link transmitter
19	Y3+			
5	YClk-	Output	Camera Link LVDS	Transmit clock from the Camera Link transmitter
18	YClk+			
8	Z0-	Output	Camera Link LVDS	Data from the Camera Link transmitter
21	Z0+			
9	Z1-	Output	Camera Link LVDS	Data from the Camera Link transmitter
22	Z1+			
10	Z2-	Output	Camera Link LVDS	Data from the Camera Link transmitter
23	Z2+			
12	Z3-	Output	Camera Link LVDS	Data from the Camera Link transmitter
25	Z3+			
11	ZClk-	Output	Camera Link LVDS	Transmit clock from the Camera Link transmitter
24	ZClk+			

Table 6: Pin Assignments for MDR Connector 2

¹ Pins 1, 13, 14, and 26 are all tied to Ground inside of the camera.

2.2.2 Pin Assignments for the 6-pin Micro-miniature Receptacle

The pin assignments for the 6-pin, micro-miniature, receptacle are as shown in Table 7.

Pin Number	Signal Name	Direction	Level	Function
1, 2 ¹	+12 VDC	Input	+12 VDC ($\pm 10\%$)	Camera power
3, 4	---	---	---	Not used
5, 6 ²	DC Gnd	Input	Ground	DC ground

Table 7: Pin Assignments for the 6-Pin Receptacle

¹ Pins 1 and 2 are tied together inside of the camera.

² Pins 5 and 6 are tied together inside of the camera.

2.2.3 Pin Numbering

Figure 13 shows the pin numbering for the connectors on the back of the camera for 2k and 4k cameras. The pin numberings for 8k cameras are analogous.

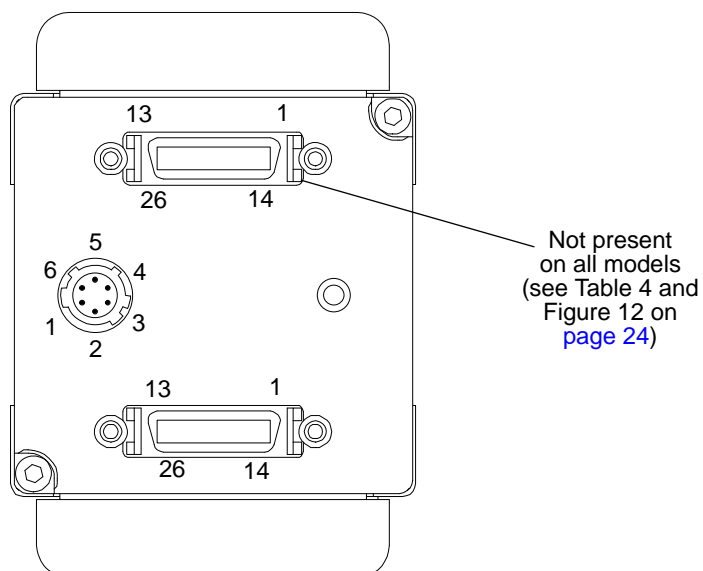

Fig. 13: Pin Numbering (2k and 4k cameras; 8k cameras are analogous)

2.3 Connector Types

2.3.1 26-pin Connectors

Each 26-pin connector on the back of the camera is a female, 0.050 inch MDR connector as called for in the Camera Link specification.

2.3.2 6-pin Connector

The 6-pin connector on the camera is a Hirose micro-miniature locking receptacle (part number HR10A-7R-6PB) or the equivalent.

The recommended mating connector is the Hirose micro-miniature locking plug (part number HR10A-7P-6S). A plug of this type should be used to terminate the cable on the power supply for the camera.

A power supply that has an output cable terminated with the correct connector is available from Basler. Contact your Basler sales representative for more information.

2.4 Cabling Requirements

2.4.1 Camera Link Cable

The Mini D Ribbon (MDR) cables used between the camera and your frame grabber must comply with the Camera Link specification. Compliant MDR cable assemblies in several different lengths are available from Basler as stock items. Contact your Basler sales representative for more information.

The maximum allowed length for the MDR cable used with a sprint camera is 10 meters.

2.4.2 Power Cable

A Hirose, 6-pin locking plug will be shipped with each camera. This plug should be used to connect the output cable on your power supply to the camera.

For proper EMI protection, the power supply cable that is terminated with the Hirose connector and attached to the camera must be a twin-cored, shielded cable. Also, the Hirose plug must be connected to the cable shield and the shield must be connected to earth ground at the power supply.

A power supply and cable assembly that meets these requirements is available from Basler. Contact your Basler sales representative for more information.



CAUTION

An Incorrect Plug Can Damage the Camera's 6-pin Connector

The plug on the cable that you attach to the camera's 6-pin connector must be a plug for 6 pins. Using a plug designed for a smaller or a larger number of pins can damage the pins in the camera's 6-pin connector.

2.5 Camera Power

Camera power must be supplied to the camera's 6-pin connector via a cable from your power supply. Nominal camera power voltage is +12 VDC ($\pm 10\%$) with less than one percent ripple. Power consumption is as shown in Table 1 on [page 2](#).

The camera has camera power overvoltage protection as described in Section 6.8 on [page 145](#).



CAUTION

Applying Incorrect Camera Power Can Damage the Camera

The nominal voltage for the camera power is 12 VDC ($\pm 10\%$). We do not recommend applying a voltage less than 10.8 VDC or greater than 13.2 VDC.

The camera has camera power undervoltage protection that is triggered if the voltage drops below 10.5 VDC. It also has camera power overvoltage protection up to 25 VDC. See Section 6.8 on [page 145](#) for more detailed information camera power voltage greater than 25 VDC can seriously damage the camera.



CAUTION

Making or Breaking Connections Incorrectly Can Damage the Camera

Be sure that all power to your camera and to your host PC is switched off before you make or break connections to the camera. Making or breaking connections when power is on can result in damage to the camera or to the frame grabber.

If you can't switch off the power, be sure that the camera power plug is the last connector that you plug into the camera when making connections and the first connector that you unplug from the camera when breaking connections.

2.6 Camera Link Implementation

The camera uses National Semiconductor DS90CR287 devices as Camera Link transmitters. For the Camera Link receivers on your frame grabber, we recommend that you use the National Semiconductor DS90CR288, the National Semiconductor DS90CR288A or an equivalent. Detailed data sheets for these components are available at the National Semiconductor web site (www.national.com). The data sheets contain all of the information that you need to implement Camera Link, including application notes.

The camera uses a National Semiconductor DS90LV048A differential line receiver to receive the RS-644 camera control input signals and the serial communication input signal defined in the Camera Link specification. A DS90LV047A differential line transmitter is used to transmit the serial communication output signal defined in the specification. Detailed spec sheets for these devices are available at the National Semiconductor web site (www.national.com).

Camera models with a single MDR connector (see Table 4 and Figure 12 on [page 24](#)) implement the "base configuration" as defined in the Camera Link specification and include one differential line transmitter. The transmitter in the camera is designated as Transmitter X. When a camera is set for a 2 tap video data output mode, it uses the base Camera Link configuration.

Camera models with two MDR connectors implement the "medium/full configuration" as defined in the Camera Link specification and include three differential line transmitters. The transmitters in the camera are designated as Transmitter X, Transmitter Y, and Transmitter Z. If a camera is set for a 4 tap video data output mode, it uses the medium Camera Link configuration and employs transmitters X and Y. If a camera is set for an 8 tap video data output mode, it uses the full Camera Link configuration and employs transmitters X, Y, and Z.



Note

Cameras that implement the medium/full configuration can also be used as base configuration cameras. To do so, simply set the camera for a 2 tap video data output mode. In this situation, only one Camera Link cable is required. The cable should be connected to MDR connector 1 on the camera and to the "base" connector on your frame grabber.

Table 5 on [page 25](#) and Table 6 on [page 26](#) show the pin assignments for the MDR connectors.

The schematic in Figure 14 on [page 32](#) shows the full configuration Camera Link implementation for the camera and a typical implementation for a full configuration frame grabber.

For more information about how the pixel data captured by the camera is assigned to the camera's transmitter(s), see Chapter 5 on [page 85](#).

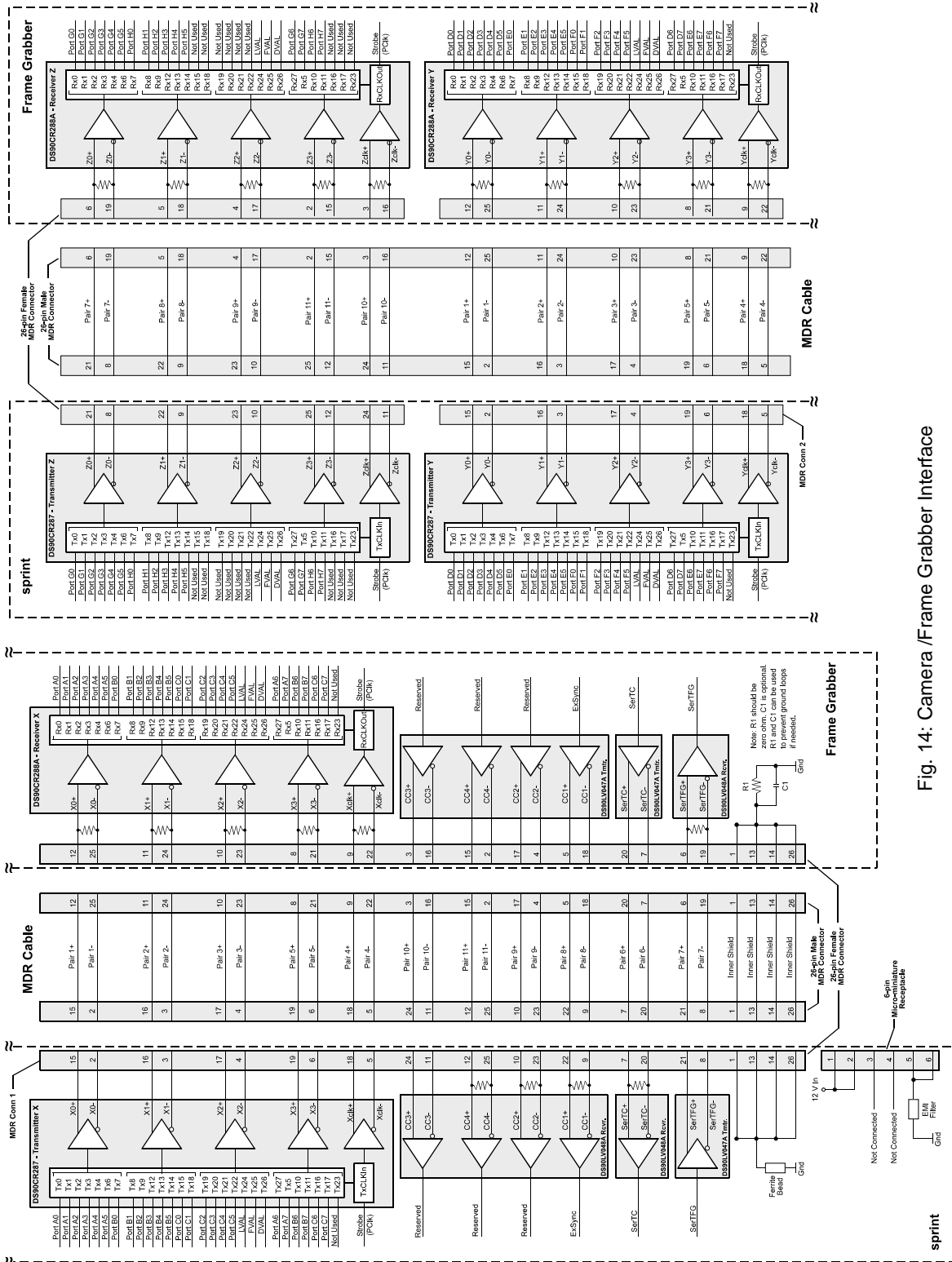

Fig. 14: Camera /Frame Grabber Interface

2.7 Input Signals

The camera's input signals include a SerTC signal and an ExSync signal as described below.

2.7.1 Serial to Camera

The Serial To Camera (SerTC) input signal is an RS-644 LVDS signal as specified in the Camera Link standard. The signal is input to the camera on pins 7 and 20 of MDR connector one as specified in the standard and as shown in Table 5 on [page 25](#) and in Figure 14 on [page 32](#).

Signals applied to the SerTC input are used to configure the camera. For more detailed information about the serial connection, see Section 2.9 on [page 37](#) and Section 7.3 on [page 196](#).

2.7.2 External Sync (ExSync)

An external sync (ExSync) signal can be input into the camera and can be used to control line acquisition and exposure time. The ExSync signal is an RS-644 LVDS signal as specified in the Camera Link standard and is usually supplied to the camera by your frame grabber. The signal is input to the camera on pins 9 and 22 of MDR connector one as shown in Table 5 on [page 25](#) and in Figure 14 on [page 32](#).

When the camera is operating under the control of an ExSync signal, three exposure time control modes are available: edge controlled, level controlled, and programmable. For more detailed information about exposure control modes, see Section 4.1 on [page 67](#).

When the camera is operating under the control of an ExSync signal, the period of the ExSync signal determines the camera's line rate:

$$\text{Line Rate} = \frac{1}{\text{ExSync Signal Period}}$$

Note that the ExSync signal is edge sensitive and therefore must toggle.

In order for the camera to detect a transition from low to high, the ExSync signal must be held high for at least 1.3 μs when the camera is set for the level controlled exposure mode and for 100 ns when the camera is set for programmable or edge controlled exposure mode.

2.8 Output Signals

Data is output from the camera in accordance with the Camera Link standard. The camera's output signals include pixel data qualifiers such as line valid and data valid, pixel data, a Camera Link clock signal, and a SerTFG signal.

2.8.1 Line Valid Bit

As shown in Figure 14 on [page 32](#), a line valid (LVAL) bit is assigned to the Tx24 pin on the X, Y, and Z Camera Link transmitters as defined in the Camera Link standard.

The line valid bit included in the video data output from the camera indicates that a valid line is being transmitted. Pixel data is only valid when this bit is high. For more detailed information about the line valid bit, see Chapter 5 on [page 85](#).

2.8.2 Data Valid Bit

As shown in Figure 14 on [page 32](#), a data valid (DVAL) bit is assigned to the Tx26 pin on the X, Y, and Z Camera Link transmitters as defined in the Camera Link standard.

The data valid bit included in the video data output from the camera indicates that valid data is being transmitted. Pixel data is only valid when this bit is high. For more detailed information about the data valid bit, see Chapter 5 on [page 85](#).

2.8.3 Pixel Data Bits

Pixel data bits are transmitted via output ports on the X, Y, and Z Camera Link transmitters. The ports as defined in the Camera Link standard are shown in Figure 14 on [page 32](#).

The assignment of pixel data bits to output ports varies depending on the video data output mode of the camera. The available video data output modes and the bit assignments are explained in detail in Chapter 5 on [page 85](#). The bit assignments comply with the Camera Link standard.

The tables also show the assignments for the line valid bit, the data valid bit, and the pixel clock. These assignments are constant for all output modes.

2.8.4 Camera Link Pixel Clock

As shown in Figure 14 on [page 32](#), the Camera Link clock signal is assigned to the strobe port (TxClkIn pin) on the X, Y, and Z Camera Link transmitters as defined in the Camera Link standard. The Camera Link clock is used to time the transmission of acquired pixel data.

As shown in Table 8, the Camera Link clock speed is fixed at 40 MHz on some camera models and can be set to either 80 MHz or to 40 MHz on some models. The default on cameras with a settable clock speed is 80 MHz.

Model	Camera Link Clock Speed
spL2048-39km	40 MHz
spL2048-70km	40 or 80 MHz
spL2048-140km	40 or 80 MHz
spL4096-20km	40 MHz
spL4096-39km	40 or 80 MHz
spL4096-70km	40 or 80 MHz
spL4096-140km	40 or 80 MHz
spL8192-20km	40 MHz
spL8192-39km	40 or 80 MHz
spL8192-70km	40 or 80 MHz

Table 8: Camera Link Clock Speed(s)

Setting the Camera Link Clock Speed

On camera models with a settable clock speed, you can set the speed with the Camera Configuration Tool Plus (CCT+) or by using binary write commands from within your own application to set the camera's control and status registers (CSRs).

With the CCT+

With the CCT+ (see Section 7.1 on [page 156](#)), you use the Camera Link Clock parameter in the Output Mode parameters group to set the clock speed.

By Setting CSRs

You set the clock speed by writing a value to the Clock Speed field of the Camera Link Clock Speed CSR (see [page 166](#)).

See Section 7.2.2 on [page 164](#) for an explanation of CSRs and Section 7.3.1 on [page 197](#) for an explanation of using read/write commands.

**Notes**

Keep in mind that a change to the Camera Link clock speed is a parameter change and that parameter changes are normally lost when the camera is reset or switched off and back on. To avoid this, you can make changes to the camera's parameters, save the changed parameters to a "user set", and then activate the user set. This will ensure that the changed parameters are saved and are loaded into the camera at reset or power off/on. For more information about saving and activating sets of parameters, see Section 6.12 on [page 149](#).

Lowering the clock speed from 80 MHz to 40 MHz may lower the camera's maximum allowed line rate. For more information about calculating the maximum allowed line rate, see Section 4.3 on [page 74](#).

Some frame grabbers are not compatible with an 80 MHz pixel clock speed. Refer to the documentation for your frame grabber to determine if it is compatible.

2.8.5 Serial to Frame Grabber

The Serial To Frame Grabber (SerTFG) output signal is an RS-644 LVDS signal as specified in the Camera Link standard. The signal is output from the camera on pins 8 and 21 of MDR connector one as specified in the standard and as shown in Table 5 on [page 25](#) and in Figure 14 on [page 32](#).

Signals from the SerTFG output are used during camera configuration. For more detailed information about the serial connection, see Section 2.9 on [page 37](#) and Section 7.3 on [page 196](#).

2.9 RS-644 Serial Communication

The camera is equipped for RS-644 serial communication via a serial port integrated into the frame grabber as specified in the Camera Link standard. The RS-644 serial connection in the Camera Link interface is used to issue commands to the camera for changing modes and parameters. The serial link can also be used to query the camera about its current setup.

The Basler Camera Configuration Tool Plus (CCT+) is a convenient, graphical interface that can be used to change camera modes and parameters via the serial connection. The configuration tool is installed on your host PC as described in the Installation and Setup Guide for Camera Link Cameras. The guide is available in the downloads section of the Basler website: www.baslerweb.com.

Basler has also developed a binary read/write command protocol that can be used to change camera modes and parameters via the serial connection from within your own application software using the API delivered with the frame grabber. See Section 7.3 on [page 196](#) for details on the binary read/write command protocol.

2.9.1 Making the Serial Connection

Frame grabbers compliant with the Camera Link specification are equipped with a serial port integrated into the Camera Link interface that can be used for RS-644 serial communication. The characteristics of the serial port can vary from manufacturer to manufacturer.

If you are using the Basler Camera Configuration Tool Plus (CCT+) to configure the camera, the tool will detect the characteristics of the serial port on the frame grabber and will determine the appropriate settings so that the tool can open and use the port.



Note

In order for the CCT+ to detect and use the port, the characteristics of the port must comply with the Camera Link standard and the `clser****.dll` called for in the standard must be present.

When the camera is powered on or when a camera reset is performed, your PC may receive one random character on the serial interface. We recommend clearing the serial input buffers in your PC after a camera power on or reset.

If you are configuring the camera using binary commands from within your application software, your software must be able to access the frame grabber serial port and to determine the appropriate settings so that it can open and use the port. Consult your frame grabber's documentation to determine the port access method and the port characteristics.

3 Line Acquisition Modes

This section describes the line acquisition modes available on the camera.

3.1 Introduction

Several different methods can be used to acquire (capture) lines with the sensor in the camera. Each of these different methods is referred to as a line acquisition mode. The line acquisition modes include:

- Single Line [Max 70 kHz]
- Dual Line [Max 140 kHz] - Line A First (spL2048-140km and spL4096-140km only)
- Dual Line [Max 140 kHz] - Line B First (spL2048-140km and spL4096-140km only)
- Vertical Binning
- Time Delayed Line Summing - Line A Delayed
- Time Delayed Line Summing - Line B Delayed
- Line Averaging
- Time Delayed Line Averaging - Line A Delayed
- Time Delayed Line Averaging - Line B Delayed

The line acquisition modes are described in detail from Section 3.2 on [page 40](#) through Section 3.5 on [page 51](#).

To understand the line acquisition modes, you must be aware of the architecture of the sensor. Refer to Figure 7 on [page 14](#) for 2k and 4k cameras, and to Figure 11 on [page 18](#) for 8k cameras. When you examine a figure, notice that the sensor contains two lines that are adjacent to each other and are oriented along the center line of the camera. Also notice that one of the lines is designated as line A and the other is designated as line B.

Horizontal Binning

A feature called horizontal binning is also described in this section. Horizontal binning is not a discrete line acquisition mode. Rather it is a function that can be used together with any of the line acquisition modes described above. For more information about horizontal binning, see Section 3.8 on [page 59](#)

3.2 Single Line [Max 70 kHz] Acquisition Mode

When single line acquisition mode is active, the camera will only use line A. Each time a line acquisition is triggered, only line A will be exposed. When line acquisition is complete (i.e., exposure is finished), the pixel values from the single line will be read out of the sensor and transmitted from the camera.

For more information about triggering line acquisition and controlling exposure, see Chapter 4 on [page 67](#).

The maximum line acquisition rate when the camera is set for this acquisition mode is 70 kHz at full resolution. If the AOI feature is used, the maximum line acquisition rate may be higher. See Section 6.2 on [page 118](#) and Section 4.3 on [page 74](#) for more information.

Setting the Camera for Single Line [Max 70 kHz] Acquisition Mode

You can set the camera for single line [max 70 kHz] acquisition mode by using the Camera Configuration Tool Plus (CCT+) or by using binary write commands from within your own application to set the camera's control and status registers (CSRs).

With the CCT+

With the CCT+ (see Section 7.1 on [page 156](#)), you use the Line Acquisition Mode parameter in the Output Mode parameters group to set the line acquisition mode to Single Line [Max 70 kHz].

By Setting CSRs

You set the line acquisition mode to single line by writing the appropriate value to the Mode field of the Line Acquisition Mode CSR (see [page 167](#)).

Section 7.2.2 on [page 164](#) explains CSRs and Section 7.3.1 on [page 197](#) explains using read/write commands.

3.3 Dual Line [Max 140 kHz] Acquisition Modes



Note

The Dual Line [Max 140 kHz] acquisition modes are only available on spL2048-140km and spL4096-140km cameras.

Two dual line acquisition modes are available:

- Dual Line [Max 140 kHz] - Line A First
- Dual Line [Max 140 kHz] - Line B First

When Dual Line [Max 140 kHz] - Line A First acquisition modes is active, the camera will use both line A and line B. When an acquisition is triggered, both lines in the sensor are exposed. When exposure is complete, the pixel values from the line A are read out of the sensor and transmitted from the camera. While the pixel values from line A are being read out, the values from line B are also read out, but they are held in a buffer in the camera. The next time that an acquisition is triggered, the pixels from line B are transmitted but no exposure will occur.

When Dual Line [Max 140 kHz] - Line B First acquisition modes is active, the camera will use both line A and line B. When an acquisition is triggered, both lines in the sensor are exposed. When exposure is complete, the pixel values from the line B are read out of the sensor and transmitted from the camera. While the pixel values from line B are being read out, the values from line A are also read out, but they are held in a buffer in the camera. The next time that an acquisition is triggered, the pixels from line A are transmitted but no exposure will occur.

If the object being imaged will cross line A first and line B second (the **image** of the object will cross line B first and line A second; see Figure 16 on [page 44](#)), you should use the Line A First mode. If the object being imaged will cross line B first and line A second (the **image** of the object will cross line A first and line B second), you should use the Line B First mode.

The maximum line acquisition rate when the camera is set for a dual line mode is 140 kHz at full resolution. If the AOI feature is used, the maximum line acquisition rate may be higher. See Section 6.2 on [page 118](#) and Section 4.3 on [page 74](#) for more information.

Two ExSync Signal Cycles Required

If you have the camera set for a dual line [max 140 kHz] acquisition mode and are you using an ExSync signal to trigger line acquisition, you should be aware that two cycles of the ExSync signal are required to acquire and transmit the two lines in the sensor.

Assuming that you have the camera set for the Line A First mode, the first cycle of the ExSync signal will:

- trigger the start of image acquisition (i.e., exposure) on BOTH lines in the sensor. The exposure time you are using will apply to BOTH lines.
- time the start of pixel data readout for both lines.
- time the start of transmission of line A pixel data.

The second cycle of the ExSync signal will be used to:

- time the start of transmission of line B pixel data.

The time line shown in Figure 15 illustrates this situation when an ExSync signal is used to trigger line acquisition, the camera is set for programmable exposure, and the camera is set for Dual Line [Max 140 kHz] - Line A First. The figure shows what occurs through two cycles of the ExSync signal.

For more information about triggering line acquisition and controlling exposure, see Chapter 4 on [page 67](#).

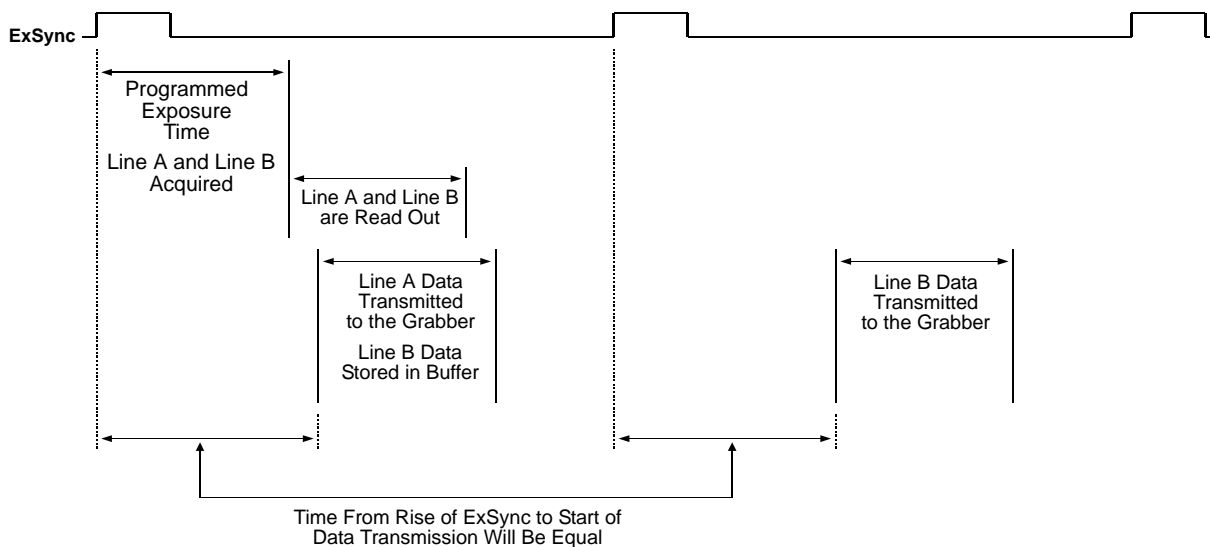

Fig. 15: Dual Line Acquisition with ExSync Programmable Exposure and Line A First

To better understand the concept of dual line acquisition, consider the example that is illustrated in Figure 16 through Figure 19. This example describes dual line acquisition (line A first) when an ExSync signal and the programmable exposure control mode are used. The example looks at four contiguous "points" on an object moving past the camera. Each point represents the area on the object that will be captured by one line in the sensor when a line acquisition is performed. As you look at the figures, notice that on the ExSync cycles where an acquisition is performed, line A will capture one point on the object and line B will capture a different point on the object. Also notice that on these cycles, the pixel data for line A will be transmitted while the pixel data for line B will be buffered. On the ExSync cycles where acquisition is not performed, the buffered pixel data for line B will be transmitted.

ExSync Cycle 1

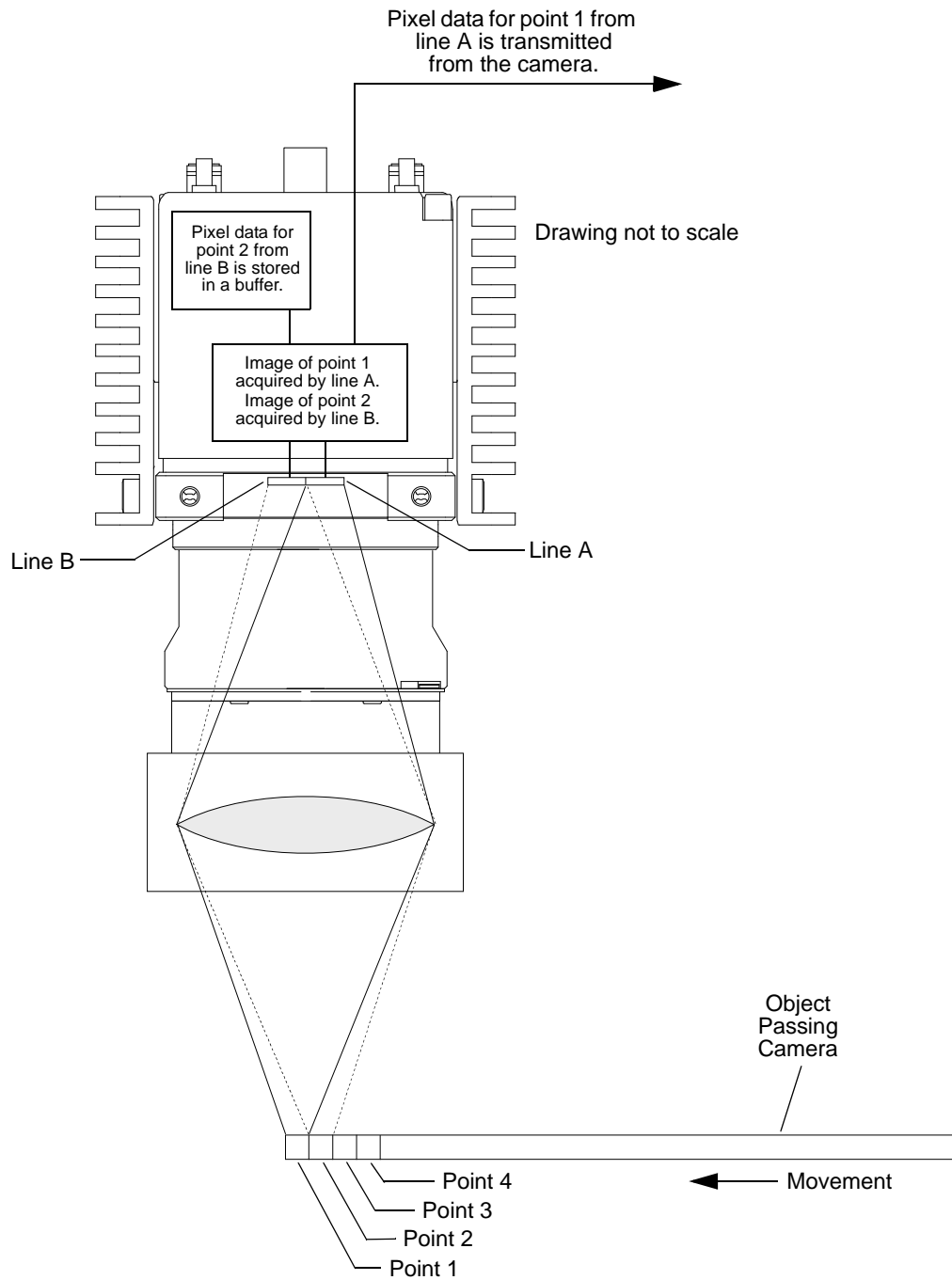

Fig. 16: Dual Line Acquisition - ExSync Cycle 1

ExSync Cycle 2

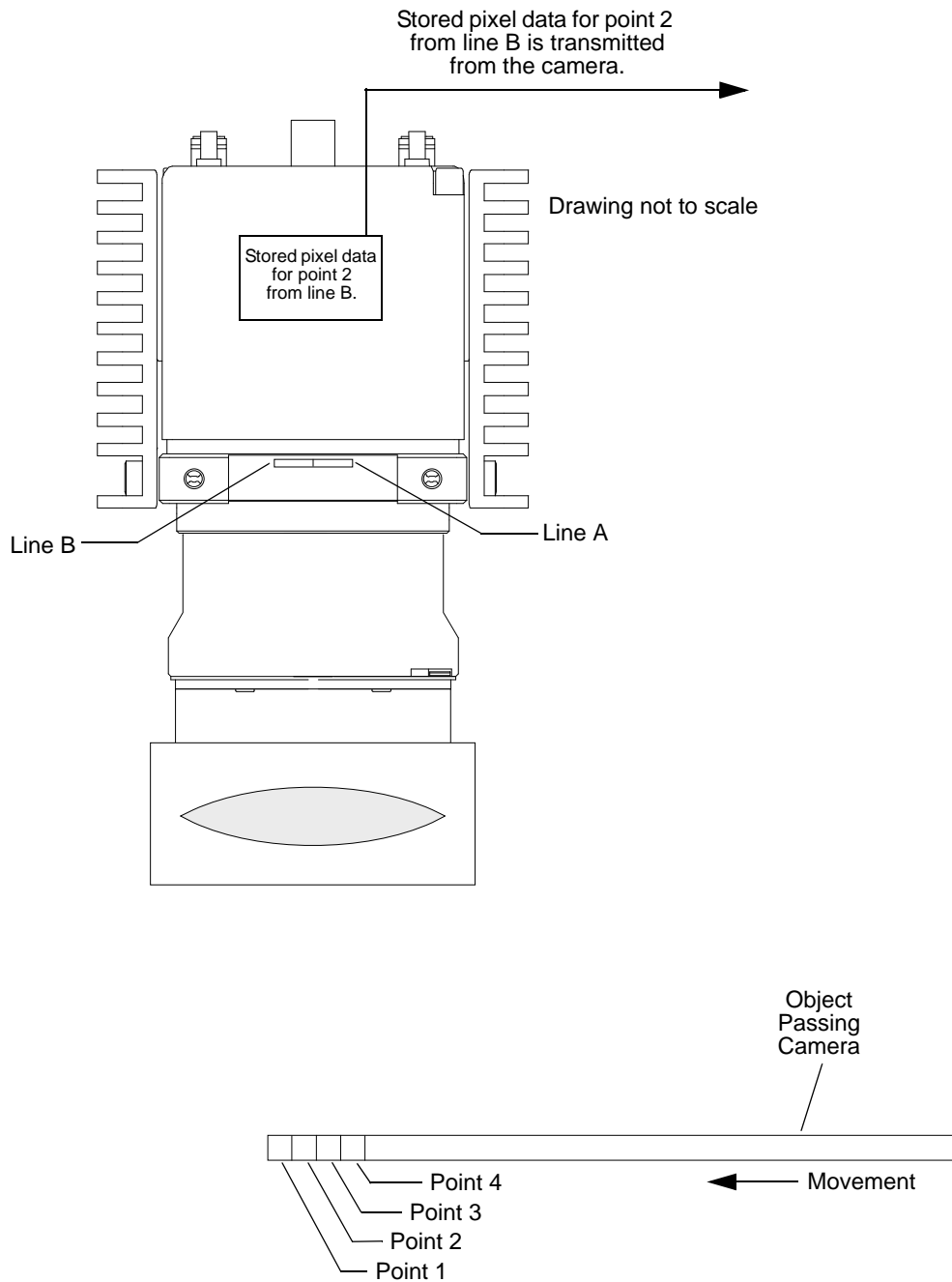

Fig. 17: Dual Line Acquisition - ExSync Cycle 2

ExSync Cycle 3

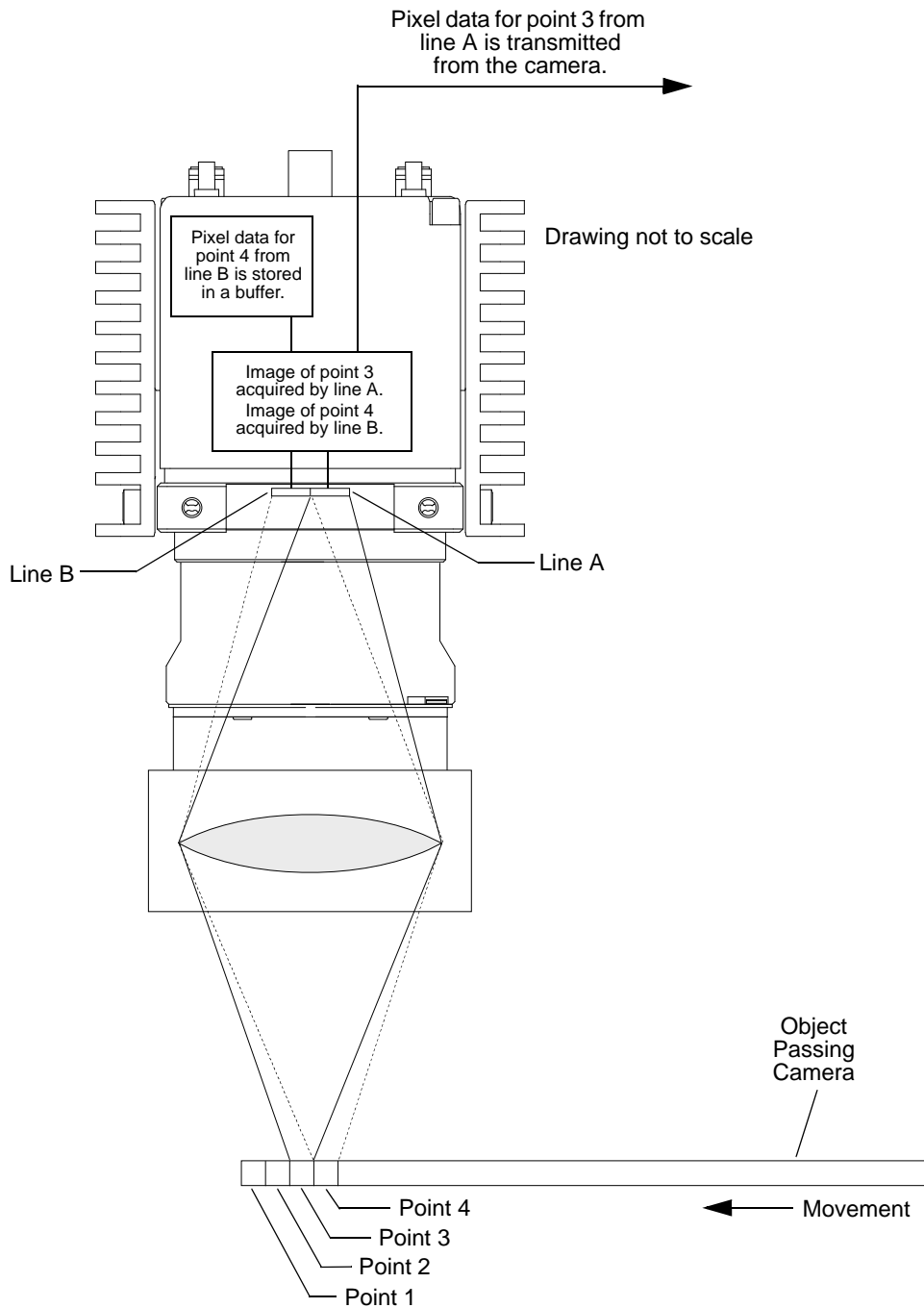

Fig. 18: Dual Line Acquisition - ExSync Cycle 3

ExSync Cycle 4

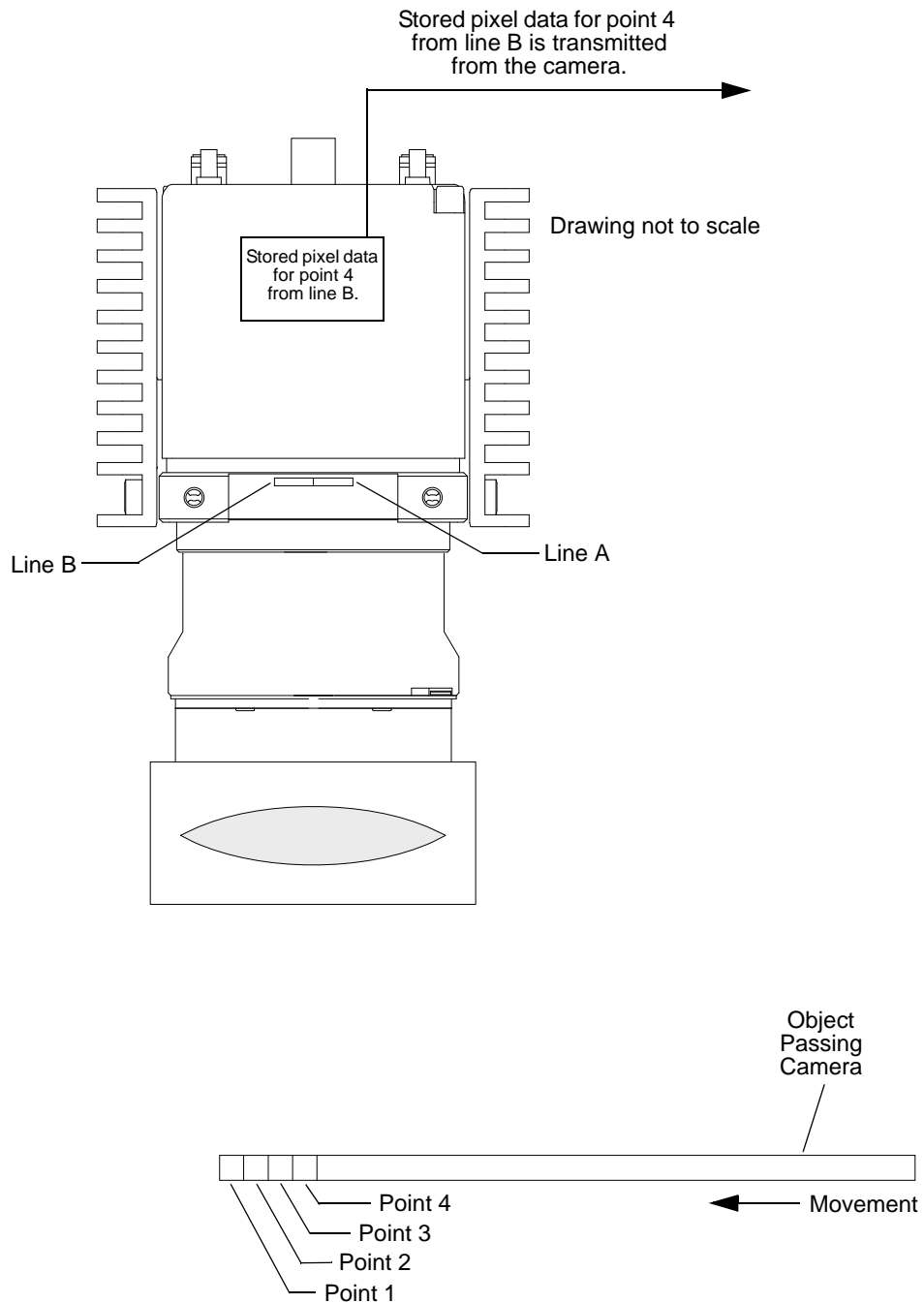

Fig. 19: Dual Line Acquisition - ExSync Cycle 4

Setting the Camera for a Dual Line [Max 140 kHz] Acquisition Mode

You can set the camera for two line acquisition mode by using the Camera Configuration Tool Plus (CCT+) or by using binary write commands from within your own application to set the camera's control and status registers (CSRs).

With the CCT+

With the CCT+ (see Section 7.1 on [page 156](#)), you use the Line Acquisition Mode parameter in the Output Mode parameters group to set the line acquisition mode to Dual Line [Max 140 kHz] - Line A First or to Dual Line [Max 140 kHz] - Line B First.

By Setting CSRs

You set the line acquisition mode to two line by writing the appropriate value to the Mode field of the Line Acquisition Mode CSR (see [page 167](#)).

Section 7.2.2 on [page 164](#) explains CSRs and Section 7.3.1 on [page 197](#) explains using read/write commands.

3.4 Vertical Binning Acquisition Mode

When the vertical binning acquisition mode is active, each time a line acquisition is triggered, the camera will expose both line A and line B. When acquisition is complete (i.e., exposure is finished), the pixel values from line A will be added to the pixel values from B in the following manner:

- The value for pixel 1 in line A will be added to the value for pixel 1 in line B
- The value for pixel 2 in line A will be added to the value for pixel 2 in line B
- The value for pixel 3 in line A will be added to the value for pixel 3 in line B
- And so on

The summed values for each pair of pixels will be transmitted from the camera as though they were from a single pixel.

Vertical binning can be useful if you are capturing images in low light conditions and you want to get an increased response from the camera. Using vertical binning will result in approximately double the response of single line acquisition.

Figure 20 illustrates vertical binning.

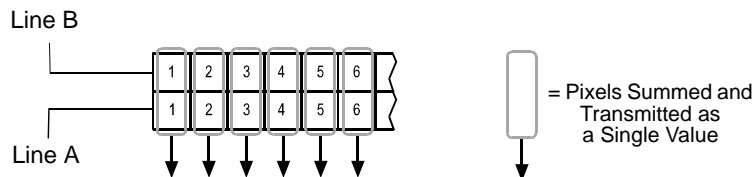

Fig. 20: Vertical Binning

The physical pixels in each line of the sensor are $10\ \mu\text{m}$ (H) x $10\ \mu\text{m}$ (V). So when you use vertical binning, you get the same effect as using a single line sensor that has $10\ \mu\text{m}$ (H) x $20\ \mu\text{m}$ (V) pixels. Some users may find the effective $10\ \mu\text{m}$ x $20\ \mu\text{m}$ pixel size to be objectionable because the effective pixel is no longer square. Note that if you use the vertical binning acquisition mode together with the camera's horizontal binning feature, the effective pixel size will become $20\ \mu\text{m}$ (H) x $20\ \mu\text{m}$ (V). In this situation, you will get a response that is approximately four times higher than normal, and you will have a square pixel size.

For more information about the horizontal binning feature, see Section 3.8 on [page 59](#).

Setting the Camera for Vertical Binning

You can set the camera for vertical binning acquisition mode by using the Camera Configuration Tool Plus (CCT+) or by using binary write commands from within your own application to set the camera's control and status registers (CSRs).

With the CCT+

With the CCT+ (see Section 7.1 on [page 156](#)), use the Line Acquisition Mode parameter in the Output Mode parameters group to set the line acquisition mode to *Vertical Binning*.

By Setting CSRs

To enable vertical binning acquisition mode, write the appropriate value to the Mode field of the Line Acquisition Mode CSR (see [page 167](#)).

Section 7.2.2 on [page 164](#) explains CSRs and Section 7.3.1 on [page 197](#) explains using read/write commands.

3.5 Time Delayed Line Summing Acquisition Mode

When the time delayed line summing acquisition mode is active, each time a line acquisition is triggered, the camera will expose both line A and line B. When line acquisition is complete (i.e., exposure is finished), the pixel values from line A and from line B will be handled in the following manner:

- The pixel values for line A will be read out of the sensor and will be stored in a buffer in the camera.
- The pixel values for line B will be read out of the sensor and they will be summed with the pixel values for line A that were stored during the previous acquisition cycle. The values will be summed in the following manner:
 - The value for pixel 1 in line A will be added to the value for pixel 1 in line B
 - The value for pixel 2 in line A will be added to the value for pixel 2 in line B
 - The value for pixel 3 in line A will be added to the value for pixel 3 in line B
 - And so on
- The summed values are transmitted out of the camera as though they were from a single captured line.

In essence, this process acquires each line on the object twice, sums the captured data, and reports the result as if it was from a single acquisition.

Line summing can be useful if you want to decrease the noise level in the pixel values output from the camera. Using line summing will result in an increase of approximately 3 dB in the signal-to-noise ratio.

To better understand the concept of time delayed line summing, consider the example that is illustrated in Figure 21 through Figure 24. The example looks at four contiguous "points" on an object moving past the camera. Each point represents the area on the object that will be captured by one line in the sensor when a line acquisition is performed. As you look at the figures, notice that when each acquisition is performed, line A will capture one point on the object and line B will capture a different point on the object.

Line A Delayed or Line B Delayed

When you use time delayed line summing, you have two choices: "time delayed line summing with line A delayed" or "time delayed line summing with line B delayed." You should use "time delayed line summing with line A delayed" if the image of the object you are capturing will pass line A first (the object being imaged will pass line B first). You should use "time delayed line summing with line B delayed" if the image of the object you are capturing will pass line B first (the object being imaged will pass line A first).

In Figure 21 through Figure 24, the image of the object is passing line A first, and line A will be delayed.

Acquisition 1

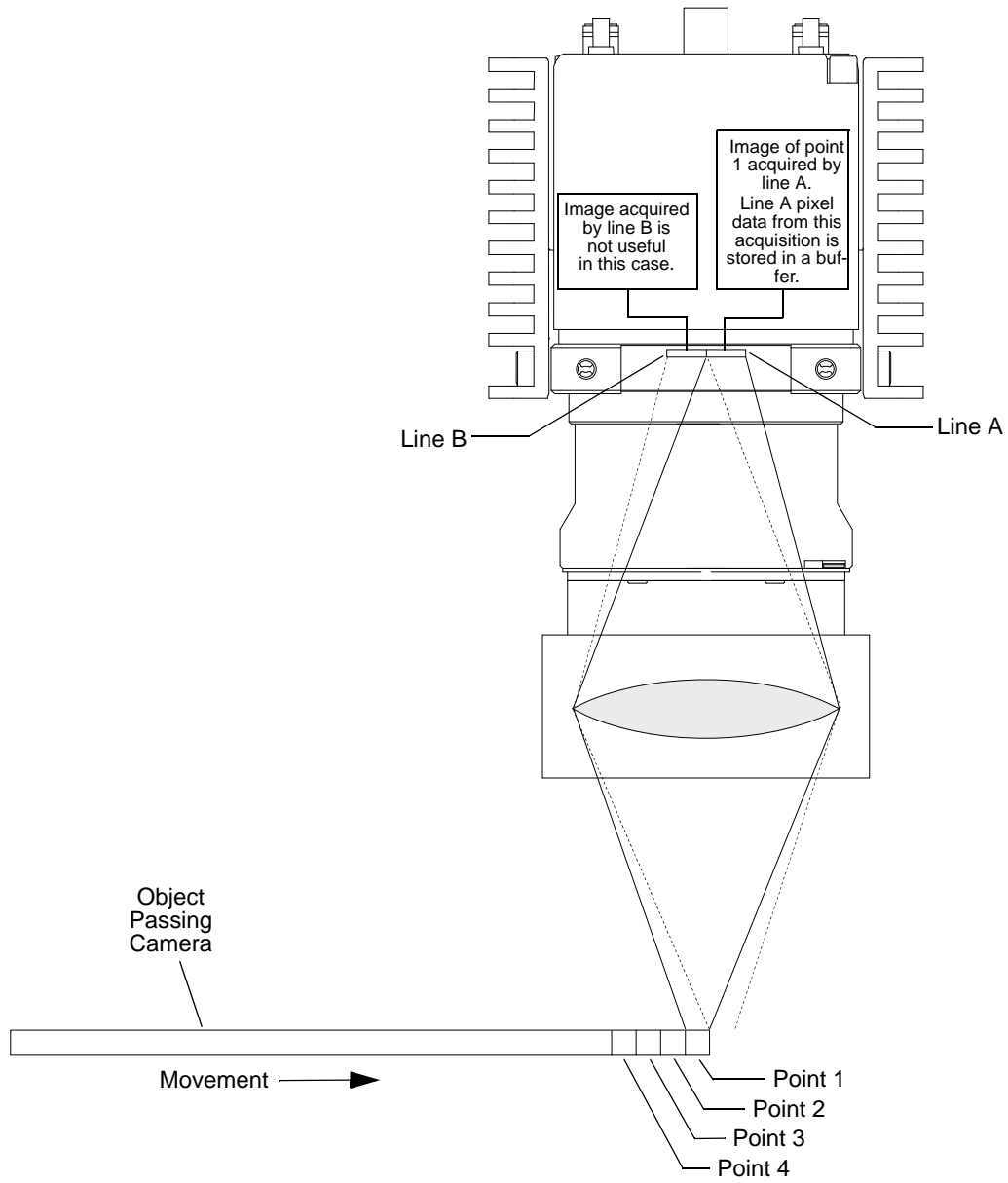

Fig. 21: Time Delayed Line Summing - Acquisition One

Acquisition 2

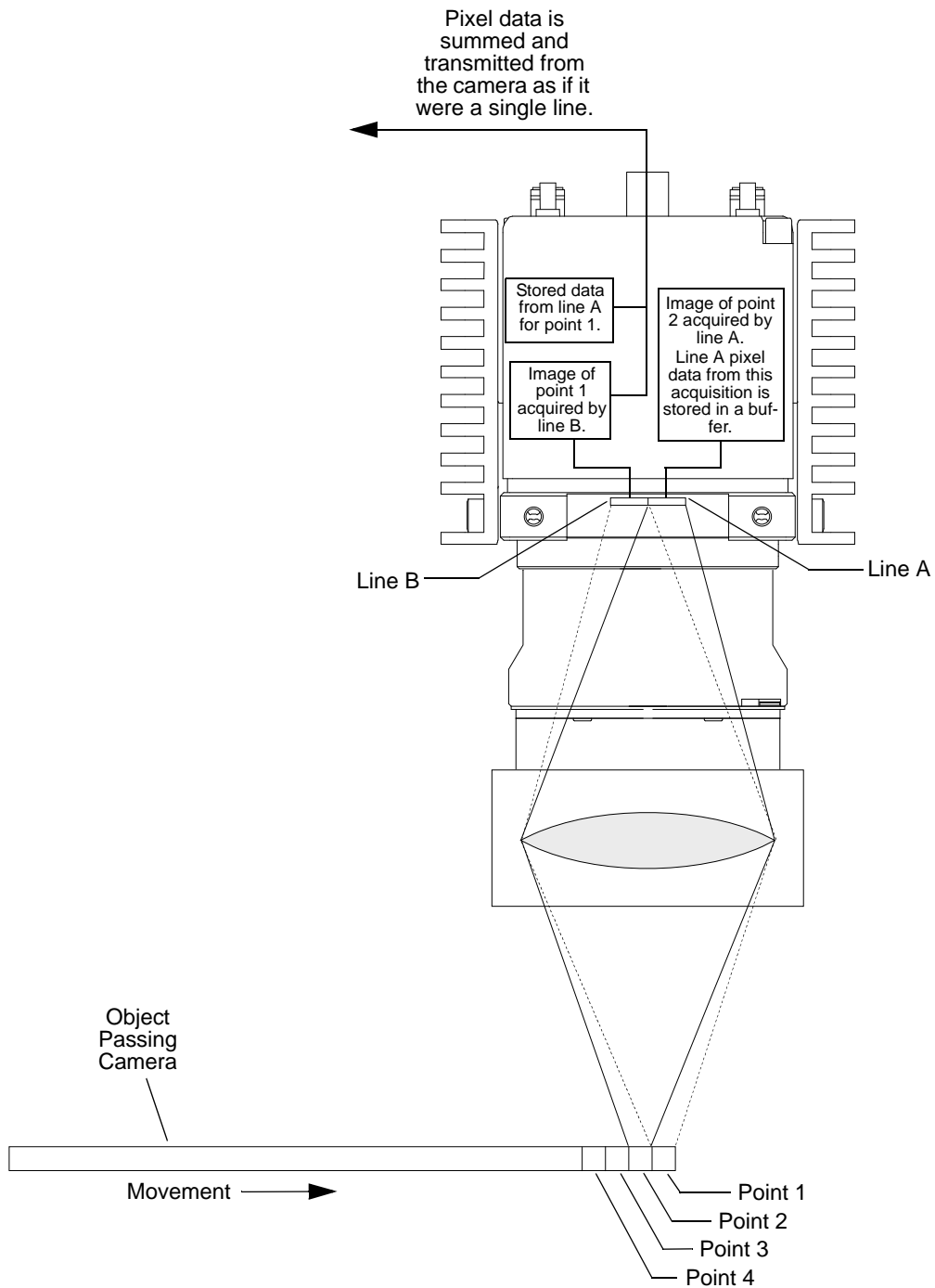

Fig. 22: Time Delayed Line Summing - Acquisition Two

Acquisition 3

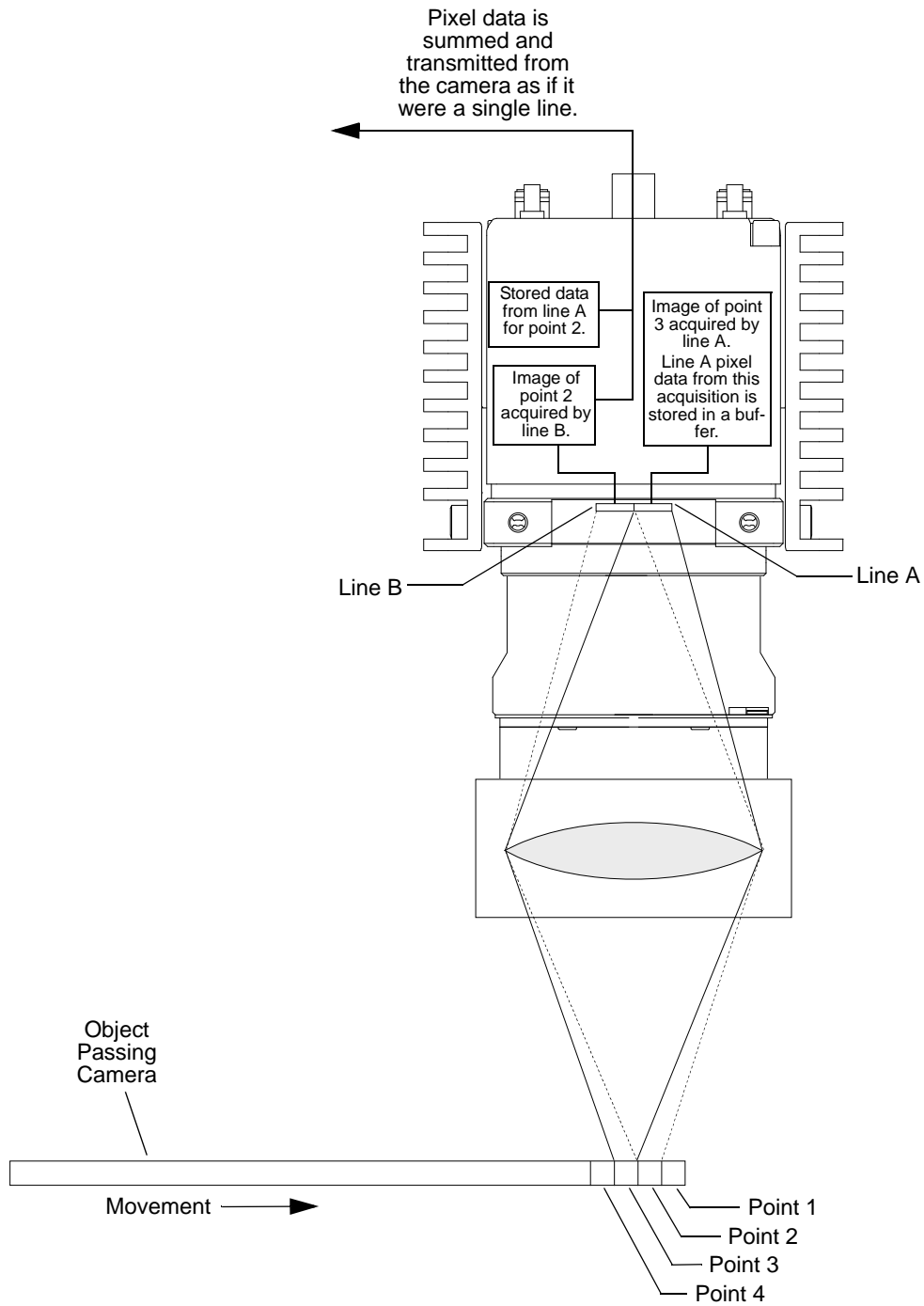

Fig. 23: Time Delayed Line Summing - Acquisition Three

Acquisition 4

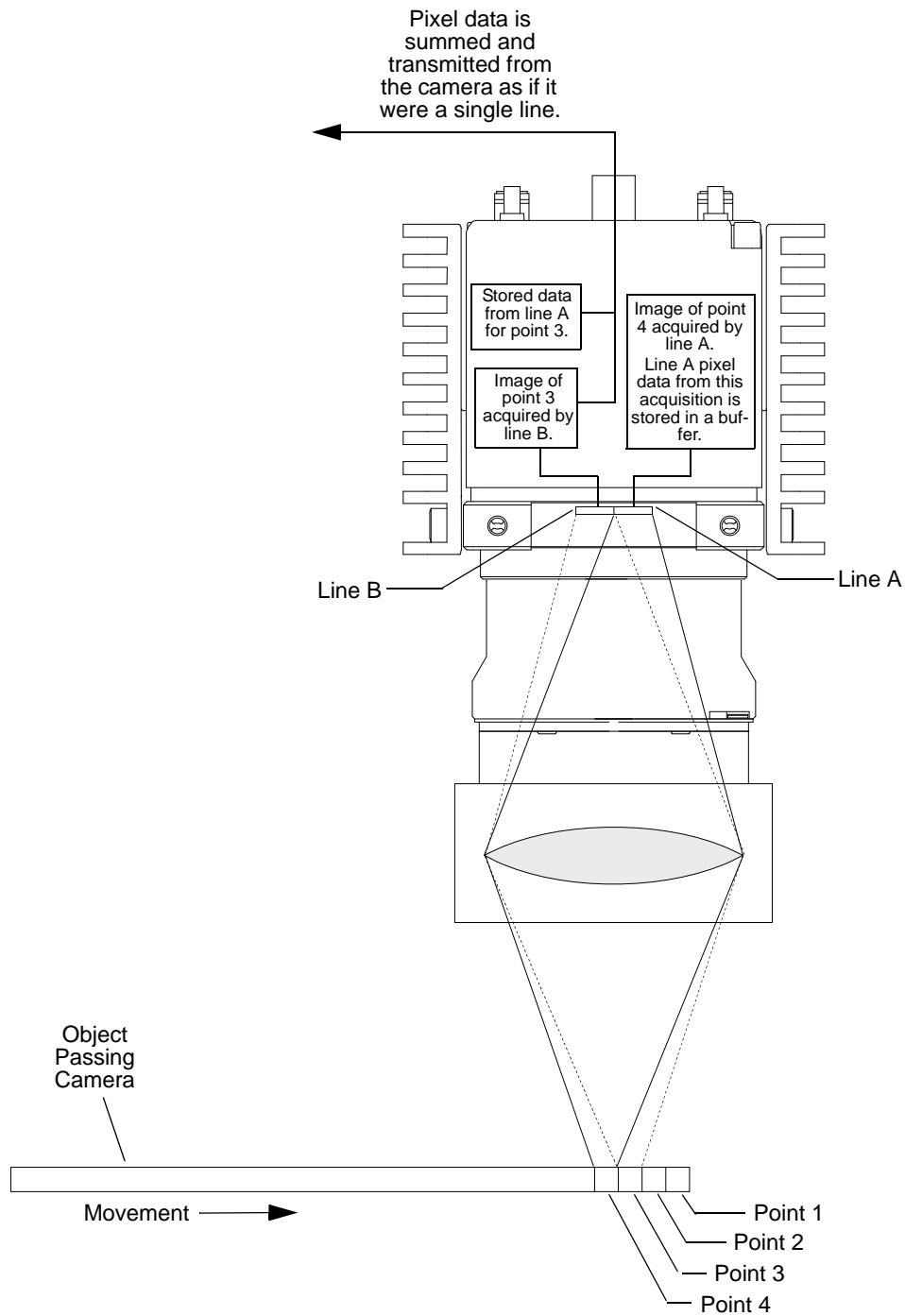

Fig. 24: Time Delayed Line Summing - Acquisition Four

Setting the Camera for Time Delayed Line Summing Acquisition Mode

You can enable the time delayed line summing acquisition mode by using the Camera Configuration Tool Plus (CCT+) or by using binary write commands from within your own application to set the camera's control and status registers (CSRs).

With the CCT+

With the CCT+ (see Section 7.1 on [page 156](#)), use the Line Acquisition Mode parameter in the Output Mode parameters group to set the line acquisition mode to *Time Delayed Line Summing - Line A Delayed* or to *Time Delayed Line Summing - Line B Delayed* as desired.

By Setting CSRs

To enable the time delayed line summing acquisition mode, write the appropriate value to the Mode field of the Line Acquisition Mode CSR (see [page 167](#)).

Section 7.2.2 on [page 164](#) explains CSRs and Section 7.3.1 on [page 197](#) explains using read/write commands.

3.6 Line Averaging Acquisition Mode

When the line averaging acquisition mode is active, each time a line acquisition is triggered, the camera will expose both line A and line B. When acquisition is complete (i.e., exposure is finished), the pixel values from line A and from B will be averaged in the following manner:

- The value for pixel 1 in line A will be added to the value for pixel 1 in line B and the total will be divided by 2 (and rounded up if necessary).
- The value for pixel 2 in line A will be added to the value for pixel 2 in line B and the total will be divided by 2 (and rounded up if necessary).
- The value for pixel 3 in line A will be added to the value for pixel 3 in line B and the total will be divided by 2 (and rounded up if necessary).
- And so on

The averaged values will then be transmitted from the camera as though they were from a single line.

The pixels in each line of the sensor are 10 µm (H) x 10 µm (V). So when you are using line averaging, you are getting the same aspect ratio as a single line sensor that is 10 µm (H) x 20 µm (V).

Setting the Camera for Line Averaging Acquisition Mode

You can enable the line averaging acquisition mode by using the Camera Configuration Tool Plus (CCT+) or by using binary write commands from within your own application to set the camera's control and status registers (CSRs).

Note that to enable line averaging, you must set a combination of two camera parameters. First, you must set the Line Acquisition Mode parameter to *Averaging*. Second, you must set the Line Delay parameter to *None*. This combination of settings results in line averaging.

With the CCT+

With the CCT+ (see Section 7.1 on [page 156](#)), use the Line Acquisition Mode parameter in the Output Mode parameters group to set the line acquisition mode to *Line Averaging*.

By Setting CSRs

To enable the line averaging acquisition mode, write the appropriate value to the Mode field of the Line Acquisition Mode CSR (see [page 167](#)).

Section 7.2.2 on [page 164](#) explains CSRs and Section 7.3.1 on [page 197](#) explains using read/write commands.

3.7 Time Delayed Line Averaging Acquisition Mode

The operation of the camera's time delayed line averaging feature is essentially the same as the time delayed line summing feature with one exception: after the pixel values have been summed, each sum is divided by 2 (and rounded up if necessary).

For more information about time delayed line summing (see Section 3.5 on [page 51](#)).

Setting the Camera for Time Delayed Line Averaging Acquisition Mode

You can enable the time delayed line averaging acquisition mode by using the Camera Configuration Tool Plus (CCT+) or by using binary write commands from within your own application to set the camera's control and status registers (CSRs).

With the CCT+

With the CCT+ (see Section 7.1 on [page 156](#)), use the Line Acquisition Mode parameter in the Output Mode parameters group to set the line acquisition mode to *Time Delayed Line Averaging - Line A Delayed* or to *Time Delayed Line Averaging - Line B Delayed* as desired.

By Setting CSRs

To enable the time delayed line averaging acquisition mode, write the appropriate value to the Mode field of the Line Acquisition Mode CSR (see [page 167](#)).

Section 7.2.2 on [page 164](#) explains CSRs and Section 7.3.1 on [page 197](#) explains using read/write commands.

3.8 Horizontal Binning

Horizontal binning is not a discrete line acquisition mode. Rather it is a function that can be used together with any of the other line acquisition modes described earlier in this section.

When horizontal binning is enabled, adjacent pixels a sensor line are summed and the sum is transmitted as a single pixel value.

For example, for Line A:

- Pixel 1 and pixel 2 in line A are summed and the sum is transmitted as a single pixel value
- Pixel 3 and pixel 4 in line A are summed and the sum is transmitted as a single pixel value
- And so on.

And for Line B:

- Pixel 1 and pixel 2 in line B are summed and the sum is transmitted as a single pixel value
- Pixel 3 and pixel 4 in line B are summed and the sum is transmitted as a single pixel value
- And so on.

Note that when horizontal binning is used with single line acquisition mode, only Line A is used and only the binned pixels from Line A are transmitted.

With horizontal binning is enabled, each pair of "binned" pixels effectively becomes a single pixel. This means that with binning enabled, the effective resolution of a sensor is halved: For cameras with 8192 pixels in each sensor line the effective resolution becomes 4096, for cameras with 4096 pixels in each sensor line the effective resolution becomes 2048, and for cameras with 2048 pixels in each sensor line the effective resolution becomes 1024. This reduced resolution has an impact on the way that the camera's area of interest feature is set. For more information about the AOI feature, see Section 6.2 on [page 118](#).

Figure 25 illustrates horizontal binning.

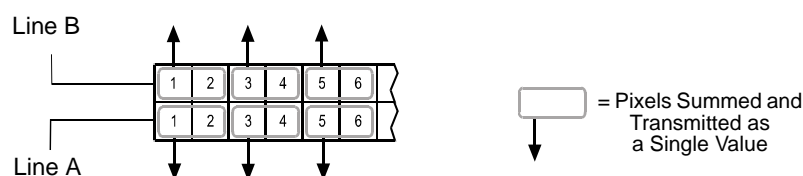

Fig. 25: Horizontal Binning

The physical pixels in each line of the sensor are $10\ \mu\text{m}$ (H) \times $10\ \mu\text{m}$ (V). With horizontal binning enabled, the effective pixel size becomes $20\ \mu\text{m}$ (H) \times $10\ \mu\text{m}$ (V). Some users may find the effective $20\ \mu\text{m} \times 10\ \mu\text{m}$ pixel size to be objectionable because the effective pixel is no longer square. Note that if you use the horizontal binning feature together with the camera's vertical binning acquisition mode, the effective pixel size will become $20\ \mu\text{m}$ (H) \times $20\ \mu\text{m}$ (V). In this situation, you will get a response that is approximately four times higher than normal, and you will have a square pixel size. For more information about the vertical binning acquisition mode, see Section 3.4 on [page 49](#).

Enabling Horizontal Binning

You can enable horizontal binning with the Camera Configuration Tool Plus (CCT+) or by using binary write commands from within your own application to set the camera's control and status registers (CSRs).

With the CCT+

With the CCT+ (see Section 7.1 on [page 156](#)), you use the Horizontal Binning parameter in the Output Mode parameters group to enable horizontal binning.

By Setting CSRs

You enable horizontal binning by writing the appropriate value to the Mode field of the Horizontal Binning CSR (see [page 168](#)).

Section 7.2.2 on [page 164](#) explains CSRs and Section 7.3.1 on [page 197](#) explains using read/write commands.

3.9 Recommendations for Using Time Delayed Line Summing or Time Delayed Line Averaging

3.9.1 Camera Operating Recommendations

To achieve the best results when using time delayed line summing or time delayed line averaging, certain operating requirements should be met.

- Exposure start should be triggered by an ExSync signal (see Chapter 4 on [page 67](#)).
- Use of the programmable exposure mode is recommended to ensure uniform exposure.
- The edge controlled or level controlled exposure modes can be used, but only if the conveyor speed is 100% stable. If the conveyor speed is not stable, unacceptable variations in exposure time will result.

3.9.2 System Design Recommendations

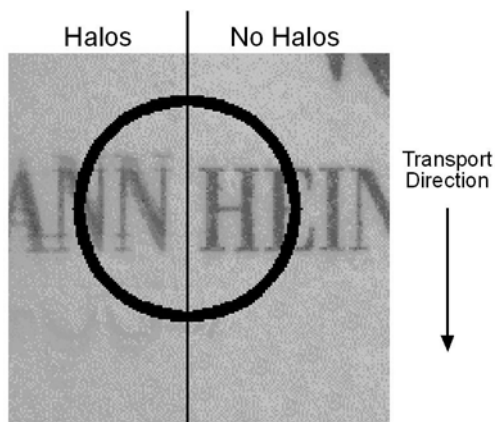

Fig. 26: The Halo Effect

When you are using time delayed line summing or time delayed line averaging, for a given point on the object to be captured correctly, its image must fall precisely on line A in the sensor and then precisely on line B in the sensor. If delayed line summing or averaging is being done correctly, the captured images will be sharp and clear as shown in the right side of Figure 26. If there are variations in the positioning of the image when it is captured by line A and by line B, the captured images will include gray “halos” as shown in the left side of Figure 26.

A list of system design requirements is given below. When these design requirements are met, the image will not have halos.

Position Encoder

You should use a position encoder to monitor the movement of the system’s conveyor. You should also use the encoder output to trigger line acquisition so that a given area of an object on the conveyor is acquired when its image falls precisely on line A and precisely on line B.

If you do not use a position encoder, haloing in the transport direction can result and the halos will vary in size.

If an encoder is used but it is not set-up correctly, haloing in the transport direction will result. In this case, the halos will be constant in size.

Conveyor Travel

The conveyor must travel in a straight line. If the conveyor motion is not straight, each line in the sensor will scan a different area of the object. This situation will cause haloing that is perpendicular to the transport direction. The halos will vary in size.

Sensor Perpendicularity

The sensor lines in the camera must be perpendicular to the conveyor's line of travel. If the sensor lines are not perpendicular to the line of travel, a slightly different area of the object will fall on each line. This situation will cause haloing that is perpendicular to the transport direction. The halos will be constant in size.

Sensor-Conveyor Parallelism

The face of the sensor in the camera and the surface of the conveyor should be in parallel planes. This condition should be met to ensure that all of the pixels in the sensor lines view the object at the same magnification.

If the camera is positioned so that the sensor is rotated on its short axis, you will see haloing in the transport direction. And if the camera is positioned so that the sensor is rotated on its long axis, you will see haloing that is perpendicular to the transport direction.

If your system design will not allow you to achieve sensor-to-conveyor parallelism, a telecentric lens setup can be used to overcome the problems that this will cause. A telecentric setup usually requires high illumination.

3.9.3 System Design Calculations

Our recommended approach for calculating system design criteria is tuned to matching the line of view of the sensor to the width of your conveyor. The example below illustrates this approach.

Example

Assume the following conditions:

- Conveyor width = 850 mm
- Conveyor movement per encoder step = 0.09 mm
- Center-to-center distance between sensor lines = 10 μm
(Each line in the sprint's sensor is 10 μm wide and they are adjacent to one another. Therefore the center-to-center distance is 10 μm .)
- Pixel size = 10 μm
- Length of sensor line = 40.96 mm (4096 pixels/line x 10 μm /pixel)
- **With an objective lens in place**, the direction of travel of the object will cause the image to cross the line A in the sensor first.

Step 1 - Calculate the magnification needed to capture the full conveyor width on a sensor line.

$$\frac{\text{Sensor Line Length}}{\text{Conveyor Width}} = \frac{40.96 \text{ mm}}{850 \text{ mm}} = 0.048$$

$$\frac{1}{0.048} = 20.83$$

$$\beta = 1 : 20.83$$

(β is the standard symbol for magnification and is usually expressed as a ratio)

Step 2 - Calculate the conveyor movement necessary to move the **image** 10 μm .

$$10 \mu\text{m} \times 20.83 = 0.2083 \text{ mm}$$

Step 3 - Calculate the number of encoder steps needed to move the conveyor 0.2083 mm.

$$\frac{0.2083 \text{ mm}}{0.09 \text{ mm/step}} = 2.31 \text{ steps}$$

Since the encoder only counts in whole steps, we have two options. We can move the conveyor enough to generate 2 encoder steps or we can move the conveyor enough to generate 3 encoder steps. In either of these cases, the movement of the conveyor will not result in the image moving exactly 10 μm . Therefore, we will need to adjust the magnification so that exactly 10 μm of image

movement results. And we must also consider that a change in magnification will result in a change in the amount of conveyor width that is viewed by each sensor line.

The calculations below look at the outcomes of our two options:

Option 1

Calculate the conveyor movement that will generate 2 encoder steps:

$$2 \text{ steps} \times 0.09 \text{ mm/step} = 0.18 \text{ mm}$$

Calculate the magnification needed to make 0.18 mm of conveyor movement result in 10 μm movement of the image:

$$\frac{10 \mu\text{m}}{0.18 \text{ mm}} = 0.056$$

$$\frac{1}{0.056} = 17,86$$

$$\beta = 1 : 17.86$$

Calculate the width of conveyor that will be viewed by each sensor line at this magnification:

$$40.96 \text{ mm} \times 17.86 = 731.55 \text{ mm}$$

Option 2

Calculate the conveyor movement that will generate 3 encoder steps:

$$3 \text{ steps} \times 0.09 \text{ mm/step} = 0.27 \text{ mm}$$

Calculate the magnification needed to make 0.27 mm of conveyor movement result in 10 μm movement of the image:

$$\frac{10 \mu\text{m}}{0.27 \text{ mm}} = 0.037$$

$$\frac{1}{0.037} = 27,03$$

$$\beta = 1 : 27.03$$

Calculate the width of conveyor that will be viewed by each sensor line at this magnification:

$$40.96 \text{ mm} \times 27.03 = 1102.92 \text{ mm}$$

If you choose to use 2 encoder steps to move the image 10 μm , you will require a 1 : 17.86 magnification and at this magnification, the field of view of each sensor line will be 731.55 mm. If you choose to use 3 encoder steps to move the image 10 μm , you will require a magnification of 1 : 27.03 and at this magnification, the field of view of each sensor line will be 1102.92 mm. Since our conveyor is 850 mm wide and since it is usually more acceptable to have a field of view slightly larger than the conveyor, assume that we choose option 2.

Step 4 - Select an appropriate lens and determine the mounting distance for your camera. You can contact Basler technical support if you need help with this procedure.

Step 5 - Make sure that the line acquisition mode is set correctly. In this case it would be set to "delayed line summing (line A delayed)". This setting is required because the image of the object will pass line A first.

Step 6 - Capture images

4 Exposure Start and Exposure Time Control

This section describes the methods that can be used to trigger the start of exposure and control the length of exposure for each acquisition. Exposure start and exposure time can be controlled via an external trigger signal (ExSync) applied to the camera. The camera can also operate in “free run.” In free run, the camera generates its own internal control signal and does not require an ExSync signal.

4.1 ExSync Controlled Operation

4.1.1 Basics of ExSync Controlled Operation

In ExSync operation, the camera’s line rate and exposure time are controlled by an externally generated trigger (ExSync) signal. The ExSync signal is typically supplied to the camera by a frame grabber board via the Camera Link cable. You should refer to the manual supplied with your frame grabber board to determine how to set up the ExSync signal that is being supplied to the camera.

When the camera is operating under the control of an ExSync signal, the length of the ExSync signal period determines the camera’s line rate:

$$\text{Line Rate} = \frac{1}{\text{ExSync Period}}$$

The ExSync signal can be periodic or non-periodic as required.

When the camera is operating with an ExSync signal, three modes of exposure time control are available: edge controlled mode, level controlled mode, and programmable mode.

- In **ExSync edge controlled** mode, line acquisition begins on the rising edge of the ExSync signal. The pixels are exposed and charge is accumulated over the full period of the ExSync signal (rising edge to rising edge). The falling edge of the ExSync signal is irrelevant. The pixel values read out of the sensor on the rising edge of ExSync (see Figure 27).

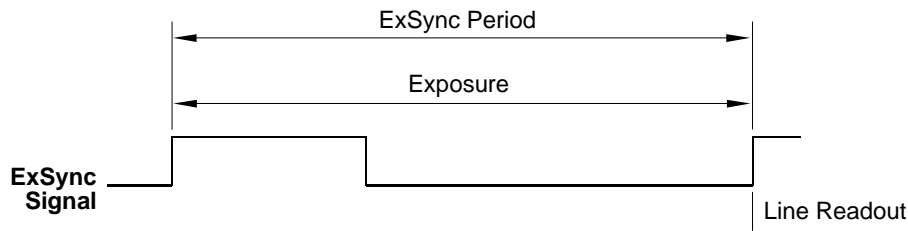

Fig. 27: ExSync Edge Controlled Mode

- In **ExSync level controlled** mode, line acquisition begins on the rising edge of the ExSync signal. The exposure time is determined by the time between the falling edge of ExSync and the next rising edge. The pixels are exposed and charge is accumulated only when ExSync is low. The pixel values are read out of the sensor on the rising edge of the ExSync signal (see Figure 28).

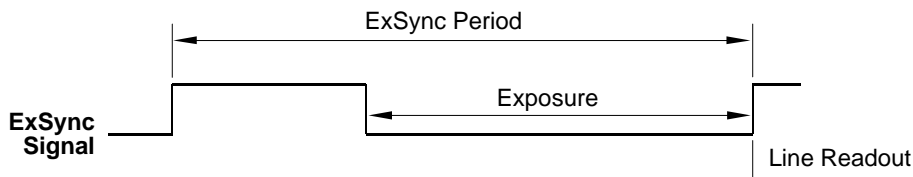

Fig. 28: ExSync Level Controlled Mode

- In **ExSync programmable** mode, line acquisition begins on the rising edge of the ExSync signal. The rising edge of ExSync triggers exposure and charge accumulation for a pre-programmed period of time. The pixel values are read out of the sensor at the end of the pre-programmed period. The falling edge of ExSync is irrelevant (see Figure 3-4).
 A parameter called "Exposure Time" is used to set the length of the pre-programmed exposure period.

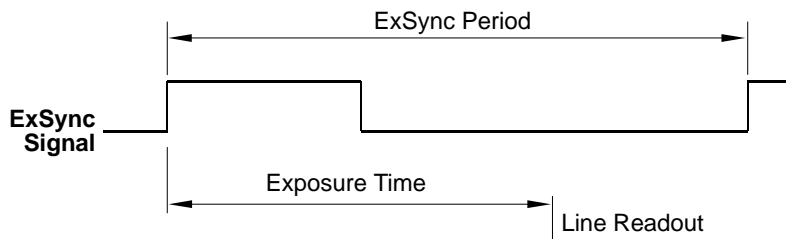

Fig. 29: ExSync Programmable Mode

4.1.2 Selecting an ExSync Exposure Mode & Setting the Exposure Time

You can select an ExSync exposure time control mode and set the exposure time for the ExSync programmable mode with the Camera Configuration Tool Plus (CCT+) or by using binary write commands from within your own application to set the camera's control and status registers (CSRs).

With the CCT+

With the CCT+ (see Section 7.1 on [page 156](#)), you use the Exposure Time Control Mode parameter in the Exposure parameters group to select the ExSync edge controlled, ExSync level controlled or ExSync programmable exposure time control mode. If you select the ExSync programmable mode, you can use the Exposure Time parameter to set the exposure time.

By Setting CSRs

You select the exposure time control mode by writing the appropriate value to the Mode field of the Exposure Time Control Mode CSR (see [page 168](#)).

If you select the ExSync programmable mode, you will also need to set the exposure time. You set the exposure time by writing a value to the Absolute Exposure Time field or to the Raw Exposure Time field of the Exposure Time CSR (see [page 169](#)).

Section 7.2.2 on [page 164](#) explains CSRs and the difference between using the "absolute" field and the "raw" field in a CSR. Section 7.3.1 on [page 197](#) explains using read/write commands.

4.1.3 Guidelines When Using an ExSync Signal

When using an ExSync signal to control exposure, several general guidelines must be followed:

- The ExSync signal must toggle.
- In order for the camera to detect a transition from low to high, the ExSync signal must be held high for at least 1.3 μs when the camera is set for the level controlled exposure mode and for at least 100 ns when the camera is set for programmable or edge controlled exposure mode.
- The ExSync signal must be held low for at least 2.0 μs .
- In ExSync edge controlled mode:
The actual exposure time = line period - 1.8 μs (± 100 ns).
- In the ExSync programmable mode:
The maximum allowed programmed exposure time = line period - 1.3 μs (± 100 ns).
(If you set the exposure time to be longer than this allowed maximum, the camera will use the set exposure time and will ignore the new ExSync signal(s) while exposure proceeds. The line rate will accordingly be decreased.)

Exposure Start Delay

In the ExSync edge controlled and ExSync programmable exposure modes, there is a slight delay between the rise of the ExSync signal and the actual start of exposure. In the ExSync level controlled mode, there is a slight delay between the fall of the ExSync signal and the actual start of exposure. This delay is commonly referred to as an exposure start delay.

The exposure start delay for each mode is as shown in the table below.

	Start Delay
ExSync Programmable ExSync Level Controlled	1.21 μs (± 20 ns)
ExSync Edge Controlled	2.51 μs (± 20 ns)

Table 9: Exposure Start Delay

4.2 Free Run

4.2.1 Basics of Free Run Controlled Operation

In free run, an ExSync signal is not required. The camera generates its own internal control signal based on two programmable parameters, “Line Period” and “Exposure Time.” The camera’s internally generated control signal rises and falls in a fashion similar to an ExSync signal.

In free run, the camera exposes and outputs lines continuously and the line period parameter setting determines the camera’s line rate:

$$\text{Line Rate} = \frac{1}{\text{Line Period}}$$

In free run, two modes of operation are available: edge controlled and programmable.

- In **free run edge controlled** mode, line acquisition begins on the rising edge of the internal control signal. The pixels are exposed and charge is accumulated over the full line period (from rising edge to rising edge of the internal control signal). The falling edge of the control signal is irrelevant. The pixel values are read out of the sensor on the rising edge of the internal control signal as shown in Figure 30. The line period is determined by the setting for the line period parameter.

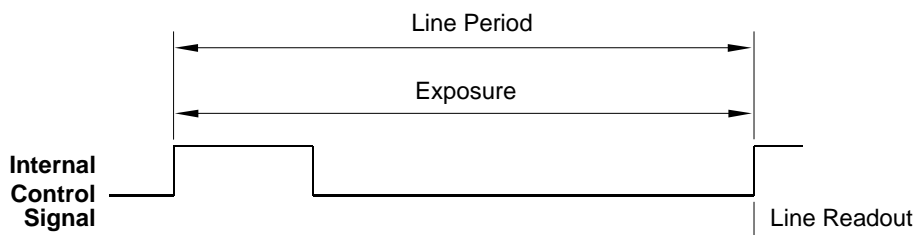

Fig. 30: Free Run, Edge Controlled Mode

- In **free run programmable** mode, line acquisition begins on the rising edge of the ExSync signal. The pixels are exposed and charge is accumulated when the internal control signal is low. The pixel values are read out of the sensor on the rising edge of the internal control signal as shown in Figure 31.

In this mode, the line period is determined by the setting for the line period parameter. The exposure time parameter setting determines how long the control signal will be low and thus determines the exposure time.

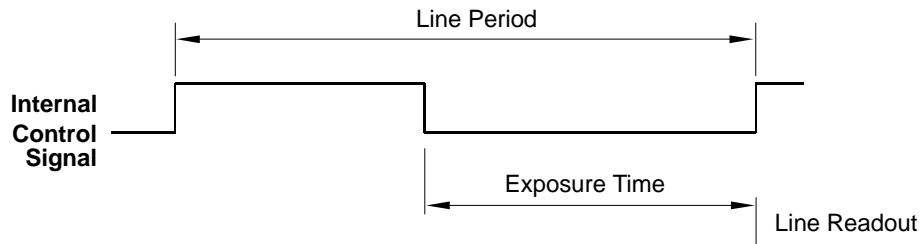

Fig. 31: Free Run, Programmable Mode

4.2.2 Selecting a Free Run Exposure Mode, Setting the Line Period, and Setting the Exposure Time

You can select a free run exposure time control mode, set the line period, and set the exposure time for the free run programmable mode with the Camera Configuration Tool Plus (CCT+) or by using binary write commands from within your own application to set the camera's control and status registers (CSRs).

With the CCT+

With the CCT+ (see Section 7.1 on [page 156](#)), you use the Exposure Time Control Mode parameter in the Exposure parameters group to select the free run edge controlled or free run programmable exposure time control mode. The Line Period parameter is used to set the line period. If you select the free run programmable mode, you can use the Exposure Time parameter to set the exposure time.

By Setting CSRs

You select the exposure time control mode by writing the appropriate value to the Mode field of the Exposure Time Control Mode CSR (see [page 168](#)).

You set the line period by writing a value in μs to the Absolute Line Period field or by writing an integer value to the Raw Line Period field of the Line Period CSR (see [page 171](#)).

If you select the free run programmable mode, you will also need to set the exposure time. You set the exposure time by writing a value in μs to the Absolute Exposure Time field or by writing an integer value to the Raw Exposure Time field of the Exposure Time CSR (see [page 169](#)).

Section 7.2.2 on [page 164](#) explains CSRs and the difference between using the “absolute” field and the “raw” field in a CSR. Section 7.3.1 on [page 197](#) explains using read/write commands.

4.2.3 Guidelines When Using Free Run

When using free run mode to control exposure, several general guidelines must be followed:

- In the free run programmable mode, the minimum exposure time and the maximum exposure time must be within the limits specified in the Exposure Time CSR (see [page 169](#)).

4.3 Maximum Allowed Line Rate / Minimum Line Period

The information in this section is intended to give you a comprehensive understanding about the factors that influence the maximum allowed line rate and how those factors interact.

In general, the maximum allowed line acquisition rate can be limited by four factors:

- The exposure time for the acquired lines. If you use long exposure times, you can acquire fewer lines per second.
- The amount of time it takes to read an acquired line out of the imaging sensor and into the camera's line buffer. This time can vary depending on the length of the area of interest (AOI) for the acquired lines. Smaller AOIs can take less time to read out.
- The amount of time that it takes to process the pixels before they are ready for transmission. This time varies by camera model.
- The amount of time it takes to transmit the pixel data for an acquired line from the camera to the host PC. This time can vary depending on the length of the area of interest (AOI) for the acquired lines. Smaller AOIs take less time to transmit.

For information about the camera settings to obtain the maximum specified line rate of the camera, see Section 4.3.4 on [page 82](#).

To determine the maximum allowed line acquisition rate with your current camera settings, you must calculate a result for the four formulas that appear below. The formula that returns the lowest value will determine the maximum allowed line rate with the current settings. (In other words, the factor that restricts the line rate the most will determine the maximum allowed line capture rate.)



Note

When operating a camera in dual line acquisition mode (see [page 39](#)), the maximum allowed line acquisition rate may be lower than suggested by the formulas given below.

Knowing the maximum allowed line acquisition rate or the minimum line period will be particularly important when you want to operate the camera under the control of an external sync signal (see [page 33](#)).

To determine the maximum allowed line acquisition rate, check the Line Period parameter in the Exposure parameter group of the CCT+ or check the absolute min field of the Line Period CSR (see [page 171](#)) and use the line period value to calculate the maximum allowed line acquisition rate.

Check the line period value before setting the camera to operate under the control of an external sync signal. The line period value will else not be indicated.

**Note**

In 8 tap video data output mode at 80 MHz, the maximum line rate for the spL2048 camera will be less than 140 MHz. The camera will, however, reach a maximum line rate of 140 MHz in 4 tap video data output mode at 80 MHz and 8 tap video data output mode at 40 MHz.

Formula 1 calculates the maximum line rate based on the exposure time:

$$\text{Max Lines / s} = \frac{1}{\text{Exposure time in s} + .0000013}$$

Formula 2 calculates the maximum line rate based on the sensor readout time:

$$\text{Max Lines / s} = \frac{160000000 \times n}{\text{Max Seg AOI Pixels} + 224}$$

Where: $n = 2$ if the camera is set for the Dual Line [Max 140 kHz] line acquisition mode (see Chapter 3 on [page 39](#))

$n = 1$ for all other line acquisition modes

Max Seg AOI Pixels is the number of AOI pixels in the segment that contains the most AOI pixels (see the explanation of Max Seg AOI Pixels on [page 77](#) for more details)

Formula 3 calculates the maximum line rate based on the amount of time it takes the camera to process the pixels read out from the sensor:

$$\text{Max Lines / s} = \frac{\text{PPR}}{\text{AOI Length} + p}$$

Where: *PPR* is the pixel processing rate for your camera model as stated in the table below:

Model	PPR
spL2048-39km	80000000
spL2048-70km	160000000
spL2048-140km	320000000

Model	PPR
spL4096-20km	80000000
spL4096-39km	160000000
spL4096-70km	320000000
spL4096-140km	640000000

Model	PPR
spL8192-20km	160000000
spL8192-39km	320000000
spL8192-70km	640000000

AOI Length is the length of the AOI based on the current AOI length setting (see Section 6.2 on [page 118](#))

$p = 0$ if the line stamp feature is not enabled (see Section 6.5 on [page 136](#))

$p = 16$ when the line stamp feature is enabled

Formula 4 calculates the maximum line rate based on the amount of time it takes to transmit the pixel data for an acquired line from the camera to the host PC:

$$\text{Max Lines / s} = \frac{\text{CL Clk} \times \text{Taps}}{(12 \times \text{Taps}) + \text{AOI Length} + p}$$

Where: *CL Clk* is the Camera Link clock speed for your camera model as stated in Table 8 on [page 35](#)

Taps is the number of taps being used as determined by the current video data output mode setting (see Chapter 5 on [page 85](#))

AOI Length is the length of the AOI based on the current AOI length setting (see Section 6.2 on [page 118](#))

$p = 0$ if the line stamp feature is not enabled (see Section 6.5 on [page 136](#))

$p = 16$ when the line stamp feature is enabled

Section 4.3.2 on [page 80](#) includes an example that illustrates how to use these formulas to determine the maximum allowed line rate.

Once you have determined the maximum allowed line rate, you can easily determine the minimum allowed line period:

$$\text{Min Line Period} = \frac{1}{\text{Max Line Rate}}$$

4.3.1 Max Segment AOI Pixels

Each sensor line in a camera is divided into segments with each segment including 2048 pixels.

In cameras equipped with sensors that have 2048 pixels per line, each line has only one segment.

In cameras equipped with sensors that have 4096 pixels per line, each line has two segments as shown in Figure 32.

In cameras equipped with sensors that have 8192 pixels per line, each line has four segments.

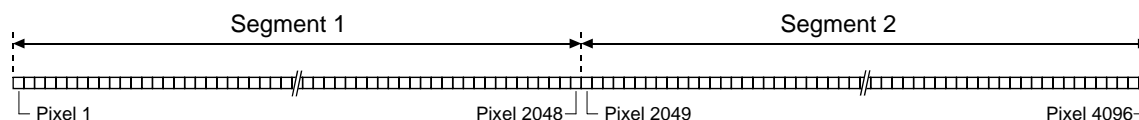

Fig. 32: Segments in Each Line of a 4096 Pixel Sensor

When you are setting up the area of interest (AOI, see Section 6.2 on [page 118](#)) on a camera with only one segment in each line, all of the pixels included in the AOI will fall into that single segment. On these cameras, the Max Seg AOI Pixels is simply the number of pixels included in the AOI. For example, if the AOI starting pixel is set to 33 and the AOI length is set to 512 on an spL2048-39km, the Max Seg AOI Pixels will be 512.

When you are setting up the AOI on a camera with two segments (4096 pixels) in each line, the pixels within the AOI may all fall into one segment. Or, the AOI could be positioned so that some of the pixels in the AOI fall into segment 1 and some of the pixels in the AOI fall into segment 2. The Max Seg AOI Pixels is defined as the number of AOI pixels included in the segment that contains the largest number of AOI pixels.

When you are setting up the AOI on a camera with four segments (8192 pixels) in each line, the pixels within the AOI may all fall into one segment. Or, the AOI could be positioned so that some of the pixels in the AOI fall into one segment and some of the pixels in the AOI fall into a neighboring segment. The Max Seg AOI Pixels is defined as the number of AOI pixels included in the segment that contains the largest number of AOI pixels. Or, the AOI could be positioned so that the pixels in the AOI fall into three or four segments. In this case, at least one complete segment will be part of the AOI and therefore the Max Seg AOI Pixels will be 2048.

Consider some examples:

- Suppose that the AOI is set to use the entire line of a 4k camera, i.e., the AOI starting pixel is 1 and the AOI length is 4096. With these settings, the number of AOI pixels in segment 1 is 2048 and the number of AOI pixels in segment 2 is 2048. The Max Seg AOI would be 2048. (In any case where the number of AOI pixels that falls into each segment is the same, the Max Seg AOI Pixels is simply the number of AOI pixels included in one of the segments).
- Suppose that the AOI starting pixel is set to 1 and the AOI length is set to 256. With these settings, all 256 pixels in the AOI would fall into segment 1. The number of AOI pixels in segment 1 is 256 and the number in segment 2 is 0. So the Max Seg AOI Pixels would be 256.
- Suppose that for a 4k camera, the AOI starting pixel is set for 1985 and the length is set for 256. With these settings, the AOI falls across the two sensor segments as shown in Figure 33.

Segment 1 includes 64 of the pixels in the AOI and segment 2 includes 192 of the pixels in the AOI. The Max Seg AOI Pixels in this situation would be 192 (because segment 2 contains the largest part of the AOI and the number of AOI pixels in segment 2 is 192).

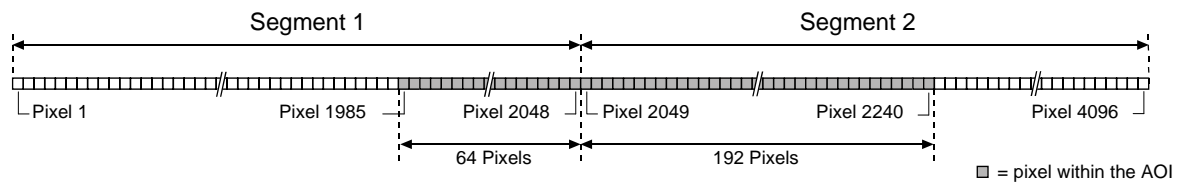

Fig. 33: AOI Falling Across Segments



Note

If you have set an AOI to extend over two adjacent sensor segments and to use each sensor segment only partially, the Max Seg AOI Pixels will be smallest when the AOI is evenly divided across the two segments (i.e., each segment contains the same number of AOI pixels). Positioning the AOI so that it is evenly divided across the two segments will yield the best results from formula two.

If you have set an AOI to extend over three or four adjacent sensor segments, at least one complete segment will be part of the AOI and therefore the Max Seg AOI Pixels will be 2048. In this case, the positioning of the AOI will not influence the result from formula two.



Note

We recommend using an AOI that is centered on the sensor when operating the camera in dual line acquisition mode (see [page 39](#)). When an AOI is centered on the sensor, the number of pixels outside of the AOI will be the same on both sides of the AOI. If an AOI is not centered, the maximum allowed line acquisition rate may be lower than suggested by the formulas given above.

If you are using an AOI that is not centered, determine the maximum allowed line acquisition rate via the CCT+ or the Line Period CSR: Check the Line Period parameter in the Exposure parameter group of the CCT+ or check the absolute min field of the Line Period CSR (see [page 171](#)) and use the line period value to calculate the maximum allowed line acquisition rate.

Knowing the maximum allowed line acquisition rate or the minimum line period will be particularly important when you want to operate the camera under the control of an external sync signal (see [page 33](#)).

Check the line period value before setting the camera to operate under the control of an external sync signal. Otherwise, the line period value will not be indicated.

Max Segment AOI Pixels with Horizontal Binning

If you have horizontal binning enabled (see Section 3.8 on [page 59](#)), calculating the Max Segment AOI Pixels is done a bit differently. With horizontal binning enabled, the resolution of the sensor, the segment size, the AOI Starting Pixel, and the AOI Length are all based on "binned" pixels. For example, with horizontal binning enabled on a camera that has 2048 physical pixels in each line, the effective resolution for each line is 1024 "binned" pixels and the number of pixels in the segment is 1024 "binned" pixels. With horizontal binning enabled on a camera that has 4096 physical pixels in each line, the effective resolution for each line is 2048 "binned" pixels and the number of pixels in each segment of a line is 1024 "binned" pixels. And with horizontal binning enabled on a camera that has 8192 physical pixels in each line, the effective resolution for each line is 4096 "binned" pixels and the number of pixels in each segment of a line is 1024 "binned" pixels.

When you are setting up the area of interest on a camera with only one segment in each line and you have horizontal binning enabled, the Max Seg AOI Pixels is simply equal to the AOI length multiplied by 2.

When you are setting up the area of interest on a camera with two or more segments in each line and you have horizontal binning enabled, you first find the segment that contains the largest number of binned pixels and then you multiply the number of binned pixels in that segment by 2.

Here is an example:

- Suppose that you are using a camera with 4096 physical pixels in each line and that horizontal binning is enabled. In this situation, the effective resolution is 2048 and the effective pixels per segment is 1024.

Assume that the AOI starting pixel is set for 929 and the length is set for 128. With these settings, the AOI falls across the two sensor segments as shown in Figure 34. Segment 1 includes 96 of the binned pixels in the AOI and segment 2 includes 32 of the binned pixels in the AOI. The Max Seg AOI Pixels in this situation would be 192 (segment 1 contains the largest part of the AOI, the number of binned AOI pixels in segment 1 is 96, and $2 \times 96 = 192$).

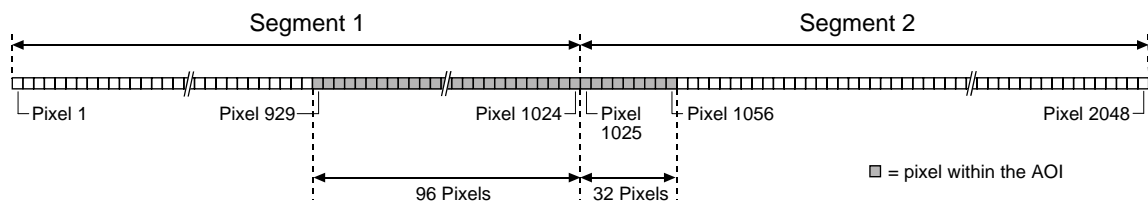

Fig. 34: AOI Falling Across Segments - Horizontal Binning Enabled

4.3.2 Example of Calculating the Maximum Allowed Line Rate / Minimum Line Period

Assume that you are working with an spL4096-140km. Also assume that the camera is set for the dual line [Max 140 kHz] line acquisition mode and 8 tap 8 bit video data output mode. The AOI starting pixel is set to 1249, AOI length is set to 2400, and the exposure time is set to 4 μ s. The stamp feature and horizontal binning are disabled.

First, you must determine the max segment AOI pixels. With the current settings 800 AOI pixels would be included in segment 1 and 1600 AOI pixels would be included in segment 2. In this case, the max segment AOI pixels is 1600.

Next, use the four formulas to calculate the maximum allowed line rate:

Formula 1:

$$\text{Max Lines / s} = \frac{1}{\text{Exposure time in s} + .0000013}$$

$$\text{Max Lines / s} = \frac{1}{.000004 + .0000013}$$

$$\text{Max Lines / s} = 188679$$

Formula 2:

$$\text{Max Lines / s} = \frac{160000000 \times n}{\text{Max Seg AOI Pixels} + 224}$$

$$\text{Max Lines / s} = \frac{160000000 \times 2}{1600 + 224}$$

$$\text{Max Lines / s} = 175438$$

Formula 3:

$$\text{Max Lines / s} = \frac{\text{PPR}}{\text{AOI Length} + p}$$

$$\text{Max Lines / s} = \frac{640000000}{2400 + 0}$$

$$\text{Max Lines / s} = 266666$$

Formula 4:

$$\text{Max Lines / s} = \frac{\text{CL Clk} \times \text{Taps}}{(12 \times \text{Taps}) + \text{AOI Length} + p}$$

$$\text{Max Lines / s} = \frac{80000000 \times 8}{(12 \times 8) + 2400 + 0}$$

$$\text{Max Lines / s} = 256410$$

Formula 2 returns the lowest value. So with the current camera settings, the maximum allowed line rate would be 175438 lines per second.

The minimum allowed line period in this case would be:

$$\text{Min Line Period} = \frac{1}{175438}$$

$$\text{Min Line Period} = 0.0000057 = 5.7 \mu\text{s}$$

4.3.3 Increasing the Maximum Allowed Line Rate

You may find that you would like to acquire lines at a rate higher than the maximum allowed with your current camera settings. If this is the case, you must first use the four formulas described on [page 74](#) to determine which factor is restricting the maximum line rate the most. Next, you must try to make that factor less restrictive:

- If you find that formula one (exposure time) is the most restrictive factor, you should decrease the exposure time. Decreasing the exposure time will increase the maximum line rate yielded by formula one. If you decrease the exposure time, you may need to compensate for a lower exposure time by using a brighter light source or by increasing the opening of your lens aperture.
- If you find that formula two (sensor readout) is the most restrictive factor, you may be able to adjust your AOI settings to decrease the Max Seg AOI Pixels. Using a smaller AOI can decrease the Max Seg AOI Pixels. Decreasing the Max Seg AOI Pixels will increase the maximum line rate yielded by formula two. Centering the AOI on the sensor may increase the maximum line rate yielded by formula two.

If you are using a camera that has two or more sensor segments and the AOI is positioned so that many pixels in the AOI fall into one sensor segment and few pixels fall into a neighboring segment, you can try repositioning your AOI. The Max Seg AOI Pixels will be smallest when the AOI is evenly divided across the two segments (i.e., each segment contains the same number of AOI pixels). If the AOI covers two complete segments or more, the Max Seg AOI Pixels will be 2048 and can not be decreased by repositioning the AOI.

- If you find that formula three (pixel processing rate) is the most restrictive factor, you can

decrease the AOI length. Decreasing the AOI length will usually increase the maximum line rate yielded by formula three.

- Formula four (transmission time) will not normally be a restricting factor. But if you are using a 2 tap or a 4 tap video data output mode, you may find that the transmission time is restricting the line rate. In this situation, you may be able to switch to an output mode that uses a larger number of taps. Using a larger number of taps will reduce the time it takes to transmit the pixel data and will increase the maximum line rate yielded by formula four. You may be able to decrease the transmission time by selecting a higher Camera Link clock speed, if available.

4.3.4 Camera Settings for the Maximum Specified Line Rate

You can obtain the camera's maximum specified line rate by combining the appropriate settings for the following parameters:

- number of taps of the video data output mode
- Camera Link clock speed
- line acquisition mode.

The combinations listed in this section apply to full resolution and horizontal binning disabled. The designation "Single" in this section refers to all line acquisition modes except the Dual Line line acquisition modes (for a list of line acquisition modes, see Section 3.1 on [page 39](#)). Accordingly, "Dual" refers to the Dual Line line acquisition modes.

When using the AOI feature, you may be able to obtain the specified line rates for additional combinations and you may obtain higher line rates than the maximum specified line rates.

As an example of choosing the appropriate settings, consider the spL4096-70km camera which has a maximum specified line rate of 70 kHz: You can obtain the maximum specified line rate at full resolution and with horizontal binning disabled for any 4 tap video data output mode, combined with 80 MHz pixel clock speed and "Single" or "Dual" line acquisition mode. You can also obtain the maximum specified line rate at full resolution and with horizontal binning disabled for the 8 tap video data output mode, combined with 40 or 80 MHz pixel clock speed and "Single" or "Dual" line acquisition mode.

The following table lists all combinations of the relevant parameters for all camera models.

Model	Taps	Camera Link Clock Speed	Line Acquisition Mode(s)
spL2048-39km	2 taps	40 MHz	Single
spL2048-70km	2 taps	80 MHz	Single
spL2048-140km	4 taps	80 MHz	Dual
	8 taps	40 MHz	Dual
spL4096-20km	2 taps	40 MHz	Single
spL4096-39km	2 taps	80 MHz	Single
	4 taps	40 MHz, 80 MHz	Single
spL4096-70km	4 taps	80 MHz	Single
	8 taps	40 MHz, 80 MHz	Single
spL4096-140km	8 taps	80 MHz	Dual
spL8192-20km	4 taps	40 MHz	Single
spL8192-39km	4 taps	80 MHz	Single
	8 taps	40 MHz, 80 MHz	Single
spL8192-70km	8 taps	80 MHz	Single

Table 10: Combinations of Parameter Settings for the Maximum Specified Line Rate

5 Video Data Output Modes

This section describes the video data output modes available on the camera. The video data output mode will determine the format of the pixel data output from the camera and will affect the camera's maximum allowed line rate.

5.1 Overview

The camera can operate in different "video data output modes." The video data output mode will determine the format of the pixel data output from the camera. The video data output modes available vary on each camera model as shown in Table 11 on [page 86](#).

The main difference between the video data output modes is the amount of pixel data that will be output on each cycle of the Camera Link pixel clock. In the 2 tap modes, data for 2 pixels will be output on each cycle. In the four tap modes, data for four pixels will be output on each pixel clock cycle. And in 8 tap mode, data for 8 pixels will be output on each pixel clock cycle. The selection of a video data output mode also determines the bit depth of the transmitted pixel data. The video data output modes are described in detail in Section 5.2.1 on [page 88](#) through Section 5.2.3 on [page 105](#).

In general, you can operate the camera at a higher maximum line rate when you use an output mode with more taps. This is true because the modes with more taps output a greater amount of pixel data on each cycle of the pixel clock and therefore require less time to output a given amount of data.

For more information about how the video data output mode will affect the camera's maximum allowed line rate, see Section 4.3 on [page 74](#).

On some camera models, the Camera Link pixel clock speed is fixed at 40 Mhz. On other models, the speed can be set to either 40 or 80 MHz. The available clock speeds on each model are also shown in Table 11. For more information about setting the Camera Link pixel clock speed, see Section 2.8.4 on [page 35](#).

.

Model	Video Data Outmode Modes	Camera link Clock Speed(s)
spL2048-39km	2 tap - 8 bit / 2 tap - 10 bit / 2 tap - 12 bit	40 MHz
spL2048-70km	2 tap - 8 bit / 2 tap - 10 bit / 2 tap - 12 bit	40 MHz or 80 MHz
spL2048-140km	2 tap - 8 bit / 2 tap - 10 bit / 2 tap - 12 bit 4 tap - 8 bit / 4 tap - 10 bit / 4 tap - 12 bit 8 tap - 8 bit*	40 MHz or 80 MHz
spL4096-20km	2 tap - 8 bit / 2 tap - 10 bit / 2 tap - 12 bit	40 MHz
spL4096-39km	2 tap - 8 bit / 2 tap - 10 bit / 2 tap - 12 bit 4 tap - 8 bit / 4 tap - 10 bit / 4 tap - 12 bit	40 MHz or 80 MHz
spL4096-70km	2 tap - 8 bit / 2 tap - 10 bit / 2 tap - 12 bit 4 tap - 8 bit / 4 tap - 10 bit / 4 tap - 12 bit 8 tap - 8 bit	40 MHz or 80 MHz
spL4096-140km	2 tap - 8 bit / 2 tap - 10 bit / 2 tap - 12 bit 4 tap - 8 bit / 4 tap - 10 bit / 4 tap - 12 bit 8 tap - 8 bit	40 MHz or 80 MHz
spL8192-20km	2 tap - 8 bit / 2 tap - 10 bit / 2 tap - 12 bit 4 tap - 8 bit / 4 tap - 10 bit / 4 tap - 12 bit	40 MHz
spL8192-39km	2 tap - 8 bit / 2 tap - 10 bit / 2 tap - 12 bit 4 tap - 8 bit / 4 tap - 10 bit / 4 tap - 12 bit 8 tap - 8 bit	40 MHz or 80 MHz
spL8192-70km	2 tap - 8 bit / 2 tap - 10 bit / 2 tap - 12 bit 4 tap - 8 bit / 4 tap - 10 bit / 4 tap - 12 bit 8 tap - 8 bit	40 MHz or 80 MHz

Table 11: Available Video Data Output Modes and Pixel Clock Speed(s)

* In 8 tap video data output mode at 80 MHz, the maximum line rate for the spL2048-140kc camera will be less than 140 MHz. The camera will, however, reach the maximum specified line rate of 140 MHz in any 4 tap video data output mode at 80 MHz and in the 8 tap video data output mode at 40 MHz. For more information about the camera settings to obtain the maximum specified line rates of the cameras, see Section 4.3.4 on [page 82](#).

5.1.1 Setting the Video Data Output Mode

You can set the video data output mode with the Camera Configuration Tool Plus (CCT+) or by using binary write commands from within your own application to set the camera's control and status registers (CSRs).

With the CCT+

With the CCT+ (see Section 7.1 on [page 156](#)), you use the Video Data Output Mode parameter in the Output Mode parameters group to set the output mode.

By Setting CSRs

You select the video data output mode by writing the appropriate value to the Mode field of the Video Data Output Mode CSR (see [page 173](#)).

See Section 7.2.2 on [page 164](#) for an explanation of CSRs and Section 7.3.1 on [page 197](#) for an explanation of using read/write commands.

5.2 Video Data Output Mode Details

**Note**

The following values for line valid and frame valid delays apply to line acquisitions at full resolution. If a shorter AOI is used, the values for line valid and frame valid delays may be smaller or larger, depending on the size and position of the AOI.

**Note**

The bit depths of the video data output modes have no effect on the values for line valid and frame valid delays.

5.2.1 2 Tap Output Modes

2 Tap - 12 Bit Output Mode

In 2 tap 12 bit mode, on each pixel clock cycle, the camera transmits data for two pixels at 12 bit depth, a line valid bit, and a data valid bit.

In the 2 tap output modes, the camera uses the output ports on Camera Link Transmitter X to transmit pixel data, a line valid bit, a data valid bit, and a pixel clock. The assignment of the bits to the output ports on Camera Link Transmitter X is as shown in Table 12 on [page 90](#).

The Camera Link clock is used to time the transmission of acquired pixel data. As shown in Figure 35 on [page 91](#) and Figure 36 on [page 92](#), the camera samples and transmits data on each rising edge of the clock. The Camera Link pixel clock frequency is as stated in Section 2.8.4 on [page 35](#).

The line valid bit indicates that a valid line is being transmitted. The data valid bit indicates that valid pixel data is being transmitted. Pixel data is only valid when the line valid and data valid bits are both high.

2 Tap - 10 Bit Output Mode

Operation in 2 tap 10 bit mode is similar to 2 tap 12 bit mode. In 10 bit mode, however, the two least significant bits output from the camera's ADCs are dropped and only the 10 most significant bits of data per pixel are transmitted.

2 Tap - 8 Bit Output Mode

Operation in 2 tap 8 bit mode is similar to 2 tap 12 bit mode. In 8 bit mode, however, the four least significant bits output from the camera's ADCs are dropped and only the 8 most significant bits of data per pixel are transmitted.



Note

The video data output mode that you select may affect the camera's maximum allowed line rate. See Section 4.3 on [page 74](#).

The data sequence outlined below, along with Figure 35 on [page 91](#) and Figure 36 on [page 92](#), describes what is happening at the inputs to the Camera Link transmitters in the camera.

5.2.1.1 Video Data Sequence for 2 Tap Output Modes

When the camera is not transmitting valid data, the line valid and data valid bits sent on each cycle of the pixel clock will be low.

Once the camera has completed an exposure, there will be a delay while data is read out of the sensor. When readout is complete, the camera will begin to transmit pixel data:

- On the clock cycle where valid pixel data transmission begins, the line valid and data valid bits both become high. Two data streams, D0 and D1 are transmitted in parallel during this clock cycle. On this clock cycle, data stream D0 will transmit data for pixel 1 in the line. Data stream D1 will transmit data for pixel 2. Depending on the video data output mode selected, the pixel data will be at 12 bit, 10 bit, or 8 bit depth.
- On the next cycle of the pixel clock, the line valid and data valid bits will both be high. On this clock cycle, data stream D0 will transmit data for pixel 3 in the line. Data stream D1 will transmit data for pixel 4.
- On the next cycle of the pixel clock, the line valid and data valid bits will be high. On this clock cycle, data stream D0 will transmit data for pixel 5 in the line. Data stream D1 will transmit data for pixel 6.
- This pattern will continue until all of the pixel data for the line has been transmitted.
- After all of the pixel data for the line has been transmitted, the line valid and data valid bits both become low indicating that valid pixel data is no longer being transmitted.

Figure 35 on [page 91](#) shows the data sequence when the camera is operating in edge-controlled or level-controlled exposure mode. Figure 36 on [page 92](#) shows the data sequence when the camera is operating in programmable exposure mode.

MDR Conn. 1, Transmitter X					
Port	Camera	Frame Grabber	Bit Assignment		
			2 Tap - 12 Bit	2 Tap - 10 Bit	2 Tap - 8 Bit
Port A0	TxIN0	RxOut0	D0 Bit 0	D0 Bit 0	D0 Bit 0
Port A1	TxIN1	RxOut1	D0 Bit 1	D0 Bit 1	D0 Bit 1
Port A2	TxIN2	RxOut2	D0 Bit 2	D0 Bit 2	D0 Bit 2
Port A3	TxIN3	RxOut3	D0 Bit 3	D0 Bit 3	D0 Bit 3
Port A4	TxIN4	RxOut4	D0 Bit 4	D0 Bit 4	D0 Bit 4
Port A5	TxIN6	RxOut6	D0 Bit 5	D0 Bit 5	D0 Bit 5
Port A6	TxIN27	RxOut27	D0 Bit 6	D0 Bit 6	D0 Bit 6
Port A7	TxIN5	RxOut5	D0 Bit 7	D0 Bit 7	D0 Bit 7 (MSB)
Port B0	TxIN7	RxOut7	D0 Bit 8	D0 Bit 8	D1 Bit 0
Port B1	TxIN8	RxOut8	D0 Bit 9	D0 Bit 9 (MSB)	D1 Bit 1
Port B2	TxIN9	RxOut9	D0 Bit 10	Not Used	D1 Bit 2
Port B3	TxIN12	RxOut12	D0 Bit 11 (MSB)	Not Used	D1 Bit 3
Port B4	TxIN13	RxOut13	D1 Bit 8	D1 Bit 8	D1 Bit 4
Port B5	TxIN14	RxOut14	D1 Bit 9	D1 Bit 9 (MSB)	D1 Bit 5
Port B6	TxIN10	RxOut10	D1 Bit 10	Not Used	D1 Bit 6
Port B7	TxIN11	RxOut11	D1 Bit 11(MSB)	Not Used	D1 Bit 7 (MSB)
Port C0	TxIN15	RxOut15	D1 Bit 0	D1 Bit 0	Not Used
Port C1	TxIN18	RxOut18	D1 Bit 1	D1 Bit 1	Not Used
Port C2	TxIN19	RxOut19	D1 Bit 2	D1 Bit 2	Not Used
Port C3	TxIN20	RxOut20	D1 Bit 3	D1 Bit 3	Not Used
Port C4	TxIN21	RxOut21'	D1 Bit 4	D1 Bit 4	Not Used
Port C5	TxIN22	RxOut22	D1 Bit 5	D1 Bit 5	Not Used
Port C6	TxIN16	RxOut16	D1 Bit 6	D1 Bit 6	Not Used
Port C7	TxIN17	RxOut17	D1 Bit 7	D1 Bit 7	Not Used
LVAL	TxIN24	RxOut24	Line Valid	Line Valid	Line Valid
FVAL	TxIN25	RxOut25	Not Used	Not Used	Not Used
DVAL	TxIN26	RxOut26	Data Valid	Data Valid	Data Valid
Spare	TxIN23	RxOut23	Not Used	Not Used	Not Used
Strobe	TxINCLK	RxOutClk	Pixel Clock	Pixel Clock	Pixel Clock

Table 12: Bit Assignments for 2 Tap Output Modes (MDR Conn. 1 - Transmitter X)

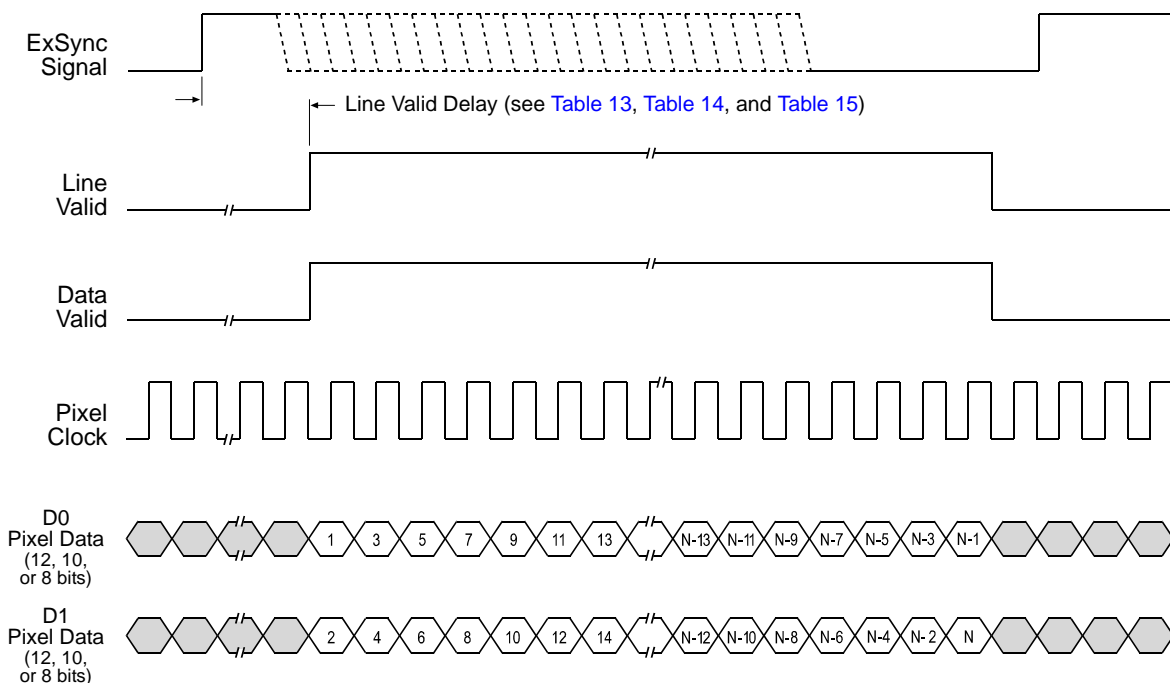

Timing diagrams are not to scale.

N = At full resolution without horizontal binning enabled, N = 8192 on 8k models, 4096 on 4k models, and 2048 on 2k models

N = At full resolution with horizontal binning enabled, N = 4096 on 8k models, 2048 on 4k models, and 1024 on 2k models

If the AOI feature is used, N will be determined by the AOI settings

Fig. 35: Two Tap Modes with Edge or Level Controlled Exposure

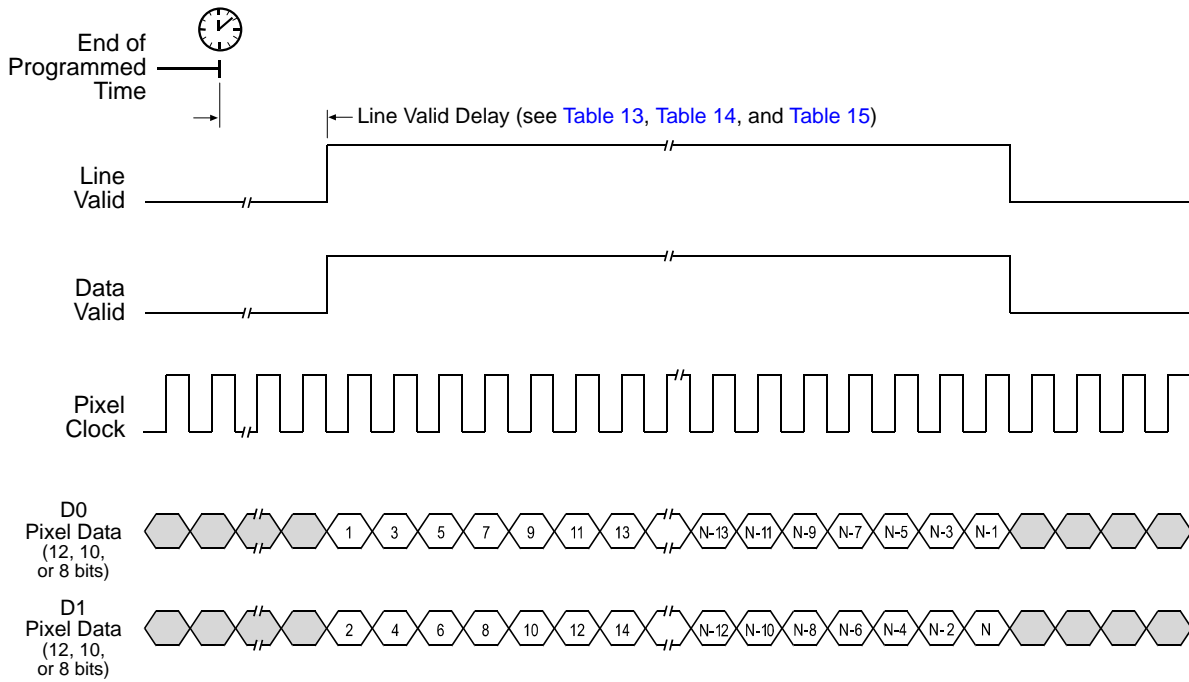

Timing diagrams are not to scale.

N = At full resolution without horizontal binning enabled, N = 8192 on 8k models, 4096 on 4k models, and 2048 on 2k models

N = At full resolution with horizontal binning enabled, N = 4096 on 8k models, 2048 on 4k models, and 1024 on 2k models

If the AOI feature is used, N will be determined by the AOI settings

Fig. 36: Two Tap Modes with Programmable Exposure

5.2.1.2 Line Valid Delays for 2 Tap Output Modes

The table below shows the line valid delay (see Figure 35 on [page 91](#) and Figure 36 on [page 92](#)) when the camera is set for full resolution and a 2 tap video data output mode. Note that the delay depends on the line acquisition mode setting, the Camera Link clock speed, and whether horizontal binning is enabled. The delay also depends on whether the camera is a 2k, 4k, or 8k camera.

Each line delay can vary slightly within the stated minimum and maximum delays.

2k Cameras

Line Valid Delays for 2 Tap Modes - 2k Cameras				
	Single Line, Time Delayed Line Summing, and Time Delayed Line Averaging Acquisition Modes - 40 MHz			
	Without Horizontal Binning		With Horizontal Binning	
	Min.	Max.	Min.	Max.
Programmable	3.18 μ s	3.31 μ s	3.73 μ s	3.86 μ s
Edge Controlled Exposure	3.23 μ s	3.36 μ s	3.78 μ s	3.91 μ s
Level Controlled Exposure	3.18 μ s	3.31 μ s	3.73 μ s	3.86 μ s
	Dual Line Acquisition Modes - 40 MHz			
	Without Horizontal Binning		With Horizontal Binning	
	Min.	Max.	Min.	Max.
Programmable	3.16 μ s	3.31 μ s	3.71 μ s	3.86 μ s
Edge Controlled Exposure	3.16 μ s	3.31 μ s	3.71 μ s	3.86 μ s
Level Controlled Exposure	3.16 μ s	3.31 μ s	3.71 μ s	3.86 μ s
	Single Line, Time Delayed Line Summing, and Time Delayed Line Averaging Acquisition Modes - 80 MHz			
	Without Horizontal Binning		With Horizontal Binning	
	Min.	Max.	Min.	Max.
Programmable	3.00 μ s	3.10 μ s	9.97 μ s	10.08 μ s
Edge Controlled Exposure	3.05 μ s	3.15 μ s	10.32 μ s	10.42 μ s
Level Controlled Exposure	3.00 μ s	3.10 μ s	9.97 μ s	10.08 μ s
	Dual Line Acquisition Modes - 80 MHz			
	Without Horizontal Binning		With Horizontal Binning	
	Min.	Max.	Min.	Max.
Programmable	2.98 μ s	3.10 μ s	9.96 μ s	10.07 μ s
Edge Controlled Exposure	2.98 μ s	3.10 μ s	9.96 μ s	10.07 μ s
Level Controlled Exposure	2.98 μ s	3.10 μ s	9.96 μ s	10.07 μ s

Table 13: Line Valid Delay with the 2k Camera Set for a 2 Tap Video Data Output Mode

4k Cameras

Line Valid Delays for 2 Tap Modes - 4k Cameras				
	Single Line, Time Delayed Line Summing, and Time Delayed Line Averaging Acquisition Modes - 40 MHz			
	Without Horizontal Binning		With Horizontal Binning	
	Min.	Max.	Min.	Max.
Programmable	3.23 μ s	3.37 μ s	3.83 μ s	3.97 μ s
Edge Controlled Exposure	3.28 μ s	3.42 μ s	4.18 μ s	4.32 μ s
Level Controlled Exposure	3.23 μ s	3.37 μ s	3.83 μ s	3.97 μ s
	Dual Line Acquisition Modes - 40 MHz			
	Without Horizontal Binning		With Horizontal Binning	
	Min.	Max.	Min.	Max.
Programmable	3.20 μ s	3.37 μ s	3.80 μ s	3.97 μ s
Edge Controlled Exposure	3.20 μ s	3.37 μ s	3.80 μ s	3.97 μ s
Level Controlled Exposure	3.20 μ s	3.37 μ s	3.80 μ s	3.97 μ s
	Single Line, Time Delayed Line Summing, and Time Delayed Line Averaging Acquisition Modes - 80 MHz			
	Without Horizontal Binning		With Horizontal Binning	
	Min.	Max.	Min.	Max.
Programmable	3.05 μ s	3.17 μ s	10.05 μ s	10.17 μ s
Edge Controlled Exposure	3.10 μ s	3.22 μ s	10.40 μ s	10.52 μ s
Level Controlled Exposure	3.05 μ s	3.17 μ s	10.05 μ s	10.17 μ s
	Dual Line Acquisition Modes - 80 MHz			
	Without Horizontal Binning		With Horizontal Binning	
	Min.	Max.	Min.	Max.
Programmable	3.03 μ s	3.15 μ s	10.05 μ s	10.18 μ s
Edge Controlled Exposure	3.03 μ s	3.15 μ s	10.05 μ s	10.18 μ s
Level Controlled Exposure	3.03 μ s	3.15 μ s	10.05 μ s	10.18 μ s

Table 14: Line Valid Delay with the 4k Camera Set for a 2 Tap Video Data Output Mode

8k Cameras

Line Valid Delays for 2 Tap Modes - 8k Cameras				
	Single Line Acquisition Mode - 40 MHz			
	Without Horizontal Binning		With Horizontal Binning	
	Min.	Max.	Min.	Max.
Programmable	3.28 μ s	3.41 μ s	3.98 μ s	4.11 μ s
Edge Controlled Exposure	3.33 μ s	3.46 μ s	4.33 μ s	4.46 μ s
Level Controlled Exposure	3.28 μ s	3.41 μ s	3.98 μ s	4.11 μ s
	Time Delayed Line Summing and Time Delayed Line Averaging Acquisition Modes - 40 MHz			
	Without Horizontal Binning		With Horizontal Binning	
	Min.	Max.	Min.	Max.
Programmable	3.33 μ s	3.46 μ s	4.03 μ s	4.16 μ s
Edge Controlled Exposure	3.38 μ s	3.51 μ s	4.38 μ s	4.51 μ s
Level Controlled Exposure	3.33 μ s	3.46 μ s	4.03 μ s	4.16 μ s
	Single Line Acquisition Mode - 80 MHz			
	Without Horizontal Binning		With Horizontal Binning	
	Min.	Max.	Min.	Max.
Programmable	3.09 μ s	3.20 μ s	10.22 μ s	10.32 μ s
Edge Controlled Exposure	3.14 μ s	3.25 μ s	10.57 μ s	10.67 μ s
Level Controlled Exposure	3.09 μ s	3.20 μ s	10.22 μ s	10.32 μ s
	Time Delayed Line Summing and Time Delayed Line Averaging Acquisition Modes - 80 MHz			
	Without Horizontal Binning		With Horizontal Binning	
	Min.	Max.	Min.	Max.
Programmable	3.12 μ s	3.22 μ s	10.24 μ s	10.35 μ s
Edge Controlled Exposure	3.17 μ s	3.27 μ s	10.59 μ s	10.70 μ s
Level Controlled Exposure	3.12 μ s	3.22 μ s	10.24 μ s	10.35 μ s

Table 15: Line Valid Delay with the 8k Camera Set for a 2 Tap Video Data Output Mode

5.2.2 4 Tap Output Modes

4 Tap - 12 Bit Output Mode

In 4 tap 12 bit mode, on each pixel clock cycle, the camera transmits data for four pixels at 12 bit depth, a line valid bit and a data valid bit.

In the 4 tap output modes, the camera uses the output ports on Camera Link Transmitters X and Y to transmit pixel data, a line valid bit, a data valid bit, and the Camera Link pixel clock. The assignment of the bits to the output ports on Camera Link Transmitters X and Y is as shown in Table 16 on [page 98](#) and Table 17 on [page 99](#) respectively.

The Camera Link clock is used to time the transmission of acquired pixel data. As shown in Figure 37 on [page 100](#) and Figure 38 on [page 101](#), the camera samples and transmits data on each rising edge of the Camera Link clock. The Camera Link pixel clock frequency is as stated in Section 2.8.4 on [page 35](#).

The line valid bit indicates that a valid line is being transmitted. The data valid bit indicates that valid pixel data is being transmitted. Pixel data is only valid when the line valid and data valid bits are both high.

4 Tap - 10 Bit Output Mode

Operation in 4 tap 10 bit mode is similar to 4 tap 12 bit mode. In 10 bit mode, however, the two least significant bits output from the camera's ADCs are dropped and only the 10 most significant bits of data per pixel are transmitted.

4 Tap - 8 Bit Output Mode

Operation in 4 tap 8 bit mode is similar to 4 tap 12 bit mode. In 8 bit mode, however, the four least significant bits output from the camera's ADCs are dropped and only the 8 most significant bits of data per pixel are transmitted.



Note

The video data output mode that you select may affect the camera's maximum allowed line rate. See Section 4.3 on [page 74](#).

The data sequence outlined below, along with Table 37 on [page 100](#) and Table 38 on [page 101](#), describes what is happening at the inputs to the Camera Link transmitters in the camera.

5.2.2.1 Video Data Sequence for 4 Tap Modes

When the camera is not transmitting valid data, the line valid and data valid bits sent on each cycle of the pixel clock will be low.

Once the camera has completed an exposure, there will be a delay while data is read out of the sensor. When readout is complete, the camera will begin to transmit pixel data:

- On the clock cycle where valid pixel data transmission begins, the line valid and data valid bits both become high. Four data streams, D0, D1, D2, and D3 are transmitted in parallel during this clock cycle. On this clock cycle, data stream D0 will transmit data for pixel 1 in the line. Data stream D1 will transmit data for pixel 2. Data stream D2 will transmit data for pixel 3. And data stream D3 will transmit data for pixel 4. Depending on the video data output mode selected, the pixel data will be at either 12 bit, 10 bit, or 8 bit depth.
- On the next cycle of the pixel clock, the line valid and data valid bits will both be high. On this clock cycle, data stream D0 will transmit data for pixel 5 in the line. Data stream D1 will transmit data for pixel 6. Data stream D2 will transmit data for pixel 7. And data stream D3 will transmit data for pixel 8.
- On the next cycle of the pixel clock, the line valid and data valid bits will be high. On this clock cycle, data stream D0 will transmit data for pixel 9 in the line. Data stream D1 will transmit data for pixel 10. Data stream D2 will transmit data for pixel 11. And data stream D3 will transmit data for pixel 12.
- This pattern will continue until all of the pixel data for the line has been transmitted.
- After all of the pixel data for the line has been transmitted, the line valid and data valid bits both become low indicating that valid pixel data is no longer being transmitted.

Figure 37 on [page 100](#) shows the data sequence when the camera is operating in edge-controlled or level-controlled exposure mode. Figure 38 on [page 101](#) shows the data sequence when the camera is operating in programmable exposure mode.

MDR Conn. 1, Transmitter X					
Port	Camera	Frame Grabber	Bit Assignment		
			4 Tap - 12 Bit	4 Tap - 10 Bit	4 Tap - 8 Bit
Port A0	TxIN0	RxOut0	D0 Bit 0	D0 Bit 0	D0 Bit 0
Port A1	TxIN1	RxOut1	D0 Bit 1	D0 Bit 1	D0 Bit 1
Port A2	TxIN2	RxOut2	D0 Bit 2	D0 Bit 2	D0 Bit 2
Port A3	TxIN3	RxOut3	D0 Bit 3	D0 Bit 3	D0 Bit 3
Port A4	TxIN4	RxOut4	D0 Bit 4	D0 Bit 4	D0 Bit 4
Port A5	TxIN6	RxOut6	D0 Bit 5	D0 Bit 5	D0 Bit 5
Port A6	TxIN27	RxOut27	D0 Bit 6	D0 Bit 6	D0 Bit 6
Port A7	TxIN5	RxOut5	D0 Bit 7	D0 Bit 7	D0 Bit 7 (MSB)
Port B0	TxIN7	RxOut7	D0 Bit 8	D0 Bit 8	D1 Bit 0
Port B1	TxIN8	RxOut8	D0 Bit 9	D0 Bit 9 (MSB)	D1 Bit 1
Port B2	TxIN9	RxOut9	D0 Bit 10	Not used	D1 Bit 2
Port B3	TxIN12	RxOut12	D0 Bit 11 (MSB)	Not used	D1 Bit 3
Port B4	TxIN13	RxOut13	D1 Bit 8	D1 Bit 8	D1 Bit 4
Port B5	TxIN14	RxOut14	D1 Bit 9	D1 Bit 9 (MSB)	D1 Bit 5
Port B6	TxIN10	RxOut10	D1 Bit 10	Not used	D1 Bit 6
Port B7	TxIN11	RxOut11	D1 Bit 11 (MSB)	Not used	D1 Bit 7 (MSB)
Port C0	TxIN15	RxOut15	D1 Bit 0	D1 Bit 0	D2 Bit 0
Port C1	TxIN18	RxOut18	D1 Bit 1	D1 Bit 1	D2 Bit 1
Port C2	TxIN19	RxOut19	D1 Bit 2	D1 Bit 2	D2 Bit 2
Port C3	TxIN20	RxOut20	D1 Bit 3	D1 Bit 3	D2 Bit 3
Port C4	TxIN21	RxOut21'	D1 Bit 4	D1 Bit 4	D2 Bit 4
Port C5	TxIN22	RxOut22	D1 Bit 5	D1 Bit 5	D2 Bit 5
Port C6	TxIN16	RxOut16	D1 Bit 6	D1 Bit 6	D2 Bit 6
Port C7	TxIN17	RxOut17	D1 Bit 7	D1 Bit 7	D2 Bit 7 (MSB0)
LVAL	TxIN24	RxOut24	Line Valid	Line Valid	Line Valid
FVAL	TxIN25	RxOut25	Not Used	Not Used	Not Used
DVAL	TxIN26	RxOut26	Data Valid	Data Valid	Data Valid
Spare	TxIN23	RxOut23	Not Used	Not Used	Not Used
Strobe	TxINCLK	RxOutClk	Pixel Clock	Pixel Clock	Pixel Clock

Table 16: Bit Assignments for 4 Tap Output Modes (MDR Conn. 1 - Transmitter X)

MDR Conn 2, Transmitter Y					
Port	Camera	Frame Grabber	Bit Assignment		
			4 Tap - 12 Bit	4 Tap - 10 Bit	4 Tap - 8 Bit
Port D0	TxIN0	RxOut0	D3 Bit 0	D3 Bit 0	D3 Bit 0
Port D1	TxIN1	RxOut1	D3 Bit 1	D3 Bit 1	D3 Bit 1
Port D2	TxIN2	RxOut2	D3 Bit 2	D3 Bit 2	D3 Bit 2
Port D3	TxIN3	RxOut3	D3 Bit 3	D3 Bit 3	D3 Bit 3
Port D4	TxIN4	RxOut4	D3 Bit 4	D3 Bit 4	D3 Bit 4
Port D5	TxIN6	RxOut6	D3 Bit 5	D3 Bit 5	D3 Bit 5
Port D6	TxIN27	RxOut27	D3 Bit 6	D3 Bit 6	D3 Bit 6
Port D7	TxIN5	RxOut5	D3 Bit 7	D3 Bit 7	D3 Bit 7 (MSB)
Port E0	TxIN7	RxOut7	D2 Bit 0	D2 Bit 0	Not used
Port E1	TxIN8	RxOut8	D2 Bit 1	D2 Bit 1	Not used
Port E2	TxIN9	RxOut9	D2 Bit 2	D2 Bit 2	Not used
Port E3	TxIN12	RxOut12	D2 Bit 3	D2 Bit 3	Not used
Port E4	TxIN13	RxOut13	D2 Bit 4	D2 Bit 4	Not used
Port E5	TxIN14	RxOut14	D2 Bit 5	D2 Bit 5	Not used
Port E6	TxIN10	RxOut10	D2 Bit 6	D2 Bit 6	Not used
Port E7	TxIN11	RxOut11	D2 Bit 7	D2 Bit 7	Not used
Port F0	TxIN15	RxOut15	D2 Bit 8	D2 Bit 8	Not used
Port F1	TxIN18	RxOut18	D2 Bit 9	D2 Bit 9 (MSB)	Not used
Port F2	TxIN19	RxOut19	D2 Bit 10	Not used	Not used
Port F3	TxIN20	RxOut20	D2 Bit 11 (MSB)	Not used	Not used
Port F4	TxIN21	RxOut21'	D3 Bit 8	D3 Bit 8	Not used
Port F5	TxIN22	RxOut22	D3 Bit 9	D3 Bit 9 (MSB)	Not used
Port F6	TxIN16	RxOut16	D3 Bit 10	Not used	Not used
Port F7	TxIN17	RxOut17	D3 Bit 11 (MSB)	Not used	Not used
LVAL	TxIN24	RxOut24	Line Valid	Line Valid	Line Valid
FVAL	TxIN25	RxOut25	Not Used	Not Used	Not Used
DVAL	TxIN26	RxOut26	Data Valid	Data Valid	Data Valid
Spare	TxIN23	RxOut23	Not Used	Not Used	Not Used
Strobe	TxINCLK	RxOutClk	Pixel Clock	Pixel Clock	Pixel Clock

Table 17: Bit Assignments for 4 Tap Output Modes (MDR Conn 2 - Transmitter Y)

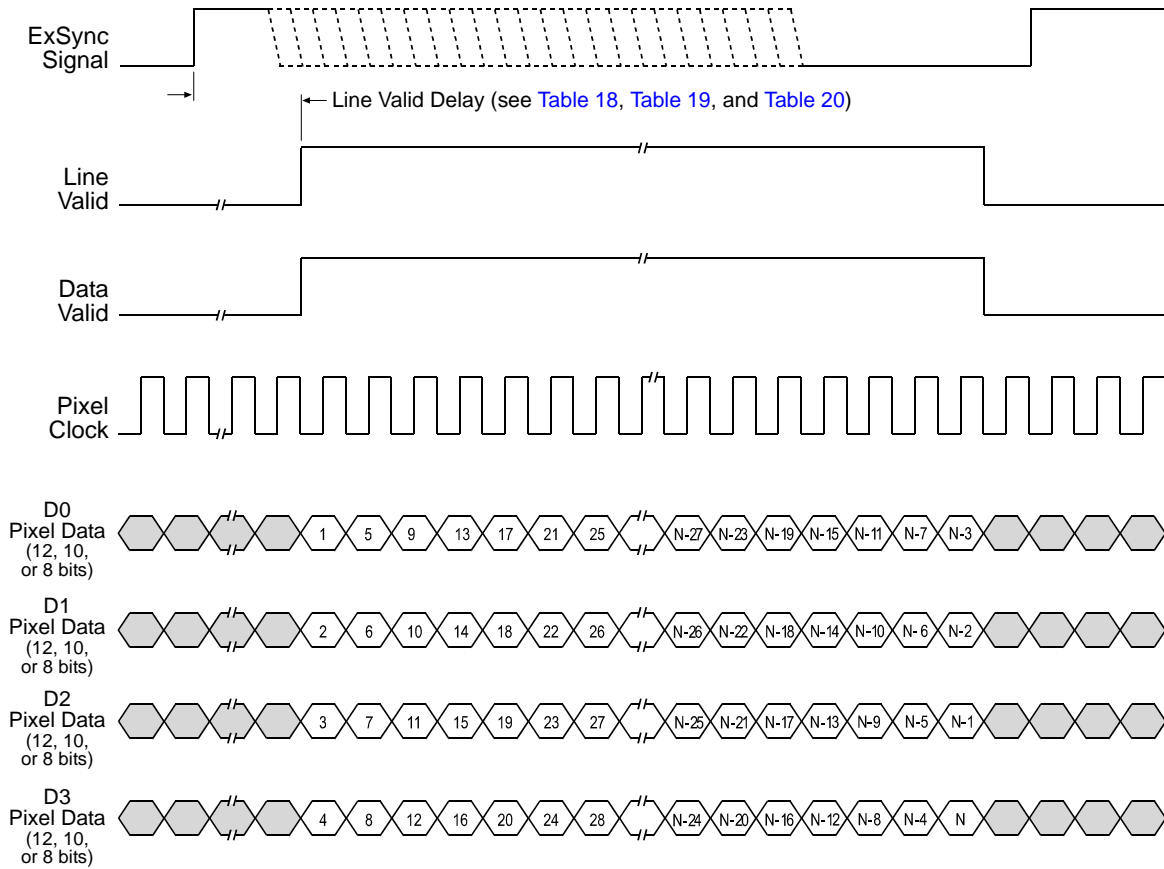

Timing diagrams are not to scale.

N = At full resolution without horizontal binning enabled, N = 8192 on 8k models, 4096 on 4k models, and 2048 on 2k models

N = At full resolution with horizontal binning enabled, N = 4096 on 8k models, 2048 on 4k models, and 1024 on 2k models

If the AOI feature is used, N will be determined by the AOI settings

Fig. 37: Four Tap Modes with Edge or Level Controlled Exposure

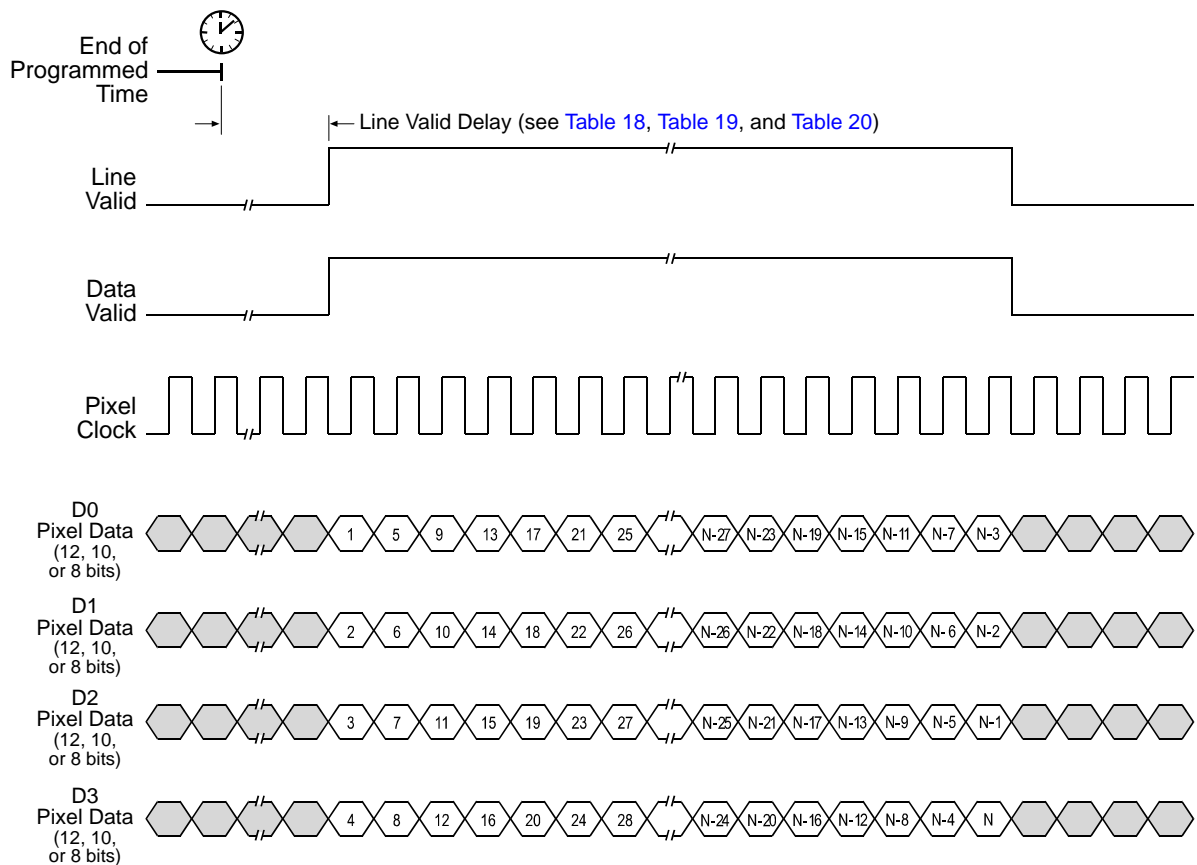

Timing diagrams are not to scale.

N = At full resolution without horizontal binning enabled, N = 8192 on 8k models, 4096 on 4k models, and 2048 on 2k models

N = At full resolution with horizontal binning enabled, N = 4096 on 8k models, 2048 on 4k models, and 1024 on 2k models

If the AOI feature is used, N will be determined by the AOI settings

Fig. 38: Four Tap Modes with Programmable Exposure

5.2.2.2 Line Valid Delays for 4 Tap Output Modes

The table below shows the line valid delay (see Figure 37 on [page 100](#) and Figure 38 on [page 101](#)) when the camera is set for full resolution and a 4 tap video data output mode. Note that the delay depends on the line acquisition mode setting, the Camera Link clock speed, and whether horizontal binning is enabled. The delay also depends on whether the camera is a 2k, 4k, or 8k camera.

Each line delay can vary slightly within the stated minimum and maximum delays.

2k Cameras

Line Valid Delays for 4 Tap Modes - 2k Cameras				
	Single Line, Time Delayed Line Summing, and Time Delayed Line Averaging Acquisition Modes - 40 MHz			
	Without Horizontal Binning		With Horizontal Binning	
	Min.	Max.	Min.	Max.
Programmable	3.18 μ s	3.31 μ s	10.15 μ s	10.28 μ s
Edge Controlled Exposure	3.23 μ s	3.36 μ s	10.50 μ s	10.63 μ s
Level Controlled Exposure	3.18 μ s	3.31 μ s	10.15 μ s	10.28 μ s
	Dual Line Acquisition Modes - 40 MHz			
	Without Horizontal Binning		With Horizontal Binning	
	Min.	Max.	Min.	Max.
Programmable	3.16 μ s	3.31 μ s	10.11 μ s	10.26 μ s
Edge Controlled Exposure	3.16 μ s	3.31 μ s	10.11 μ s	10.26 μ s
Level Controlled Exposure	3.16 μ s	3.31 μ s	10.11 μ s	10.26 μ s
	Single Line, Time Delayed Line Summing, and Time Delayed Line Averaging Acquisition Modes - 80 MHz			
	Without Horizontal Binning		With Horizontal Binning	
	Min.	Max.	Min.	Max.
Programmable	9.40 μ s	9.50 μ s	13.17 μ s	13.27 μ s
Edge Controlled Exposure	9.75 μ s	9.85 μ s	13.52 μ s	13.63 μ s
Level Controlled Exposure	9.40 μ s	9.50 μ s	13.17 μ s	13.27 μ s
	Dual Line Acquisition Modes - 80 MHz			
	Without Horizontal Binning		With Horizontal Binning	
	Min.	Max.	Min.	Max.
Programmable	9.40 μ s	9.51 μ s	13.15 μ s	13.26 μ s
Edge Controlled Exposure	9.40 μ s	9.51 μ s	13.15 μ s	13.26 μ s
Level Controlled Exposure	9.40 μ s	9.51 μ s	13.15 μ s	13.26 μ s

Table 18: Line Valid Delay with the 2k Camera Set for a 4 Tap Video Data Output Mode

4k Cameras

Line Valid Delays for 4 Tap Modes - 4k Cameras				
	Single Line, Time Delayed Line Summing, and Time Delayed Line Averaging Acquisition Modes - 40 MHz			
	Without Horizontal Binning		With Horizontal Binning	
	Min.	Max.	Min.	Max.
Programmable	3.22 μ s	3.34 μ s	10.24 μ s	10.36 μ s
Edge Controlled Exposure	3.27 μ s	3.39 μ s	10.59 μ s	10.71 μ s
Level Controlled Exposure	3.22 μ s	3.34 μ s	10.24 μ s	10.36 μ s
	Dual Line Acquisition Modes - 40 MHz			
	Without Horizontal Binning		With Horizontal Binning	
	Min.	Max.	Min.	Max.
Programmable	3.20 μ s	3.34 μ s	10.22 μ s	10.37 μ s
Edge Controlled Exposure	3.20 μ s	3.34 μ s	10.22 μ s	10.37 μ s
Level Controlled Exposure	3.20 μ s	3.34 μ s	10.22 μ s	10.37 μ s
	Single Line, Time Delayed Line Summing, and Time Delayed Line Averaging Acquisition Modes - 80 MHz			
	Without Horizontal Binning		With Horizontal Binning	
	Min.	Max.	Min.	Max.
Programmable	9.44 μ s	9.54 μ s	13.27 μ s	13.36 μ s
Edge Controlled Exposure	9.79 μ s	9.89 μ s	13.62 μ s	13.71 μ s
Level Controlled Exposure	9.44 μ s	9.54 μ s	13.27 μ s	13.36 μ s
	Dual Line Acquisition Modes - 80 MHz			
	Without Horizontal Binning		With Horizontal Binning	
	Min.	Max.	Min.	Max.
Programmable	9.43 μ s	9.54 μ s	13.26 μ s	13.36 μ s
Edge Controlled Exposure	9.43 μ s	9.54 μ s	13.26 μ s	13.36 μ s
Level Controlled Exposure	9.43 μ s	9.54 μ s	13.26 μ s	13.36 μ s

Table 19: Line Valid Delay with the 4k Camera Set for a 4 Tap Video Data Output Mode

8k Cameras

Line Valid Delays for 4 Tap Modes - 8k Cameras				
	Single Line Acquisition Mode - 40 MHz			
	Without Horizontal Binning		With Horizontal Binning	
	Min.	Max.	Min.	Max.
Programmable	3.28 μ s	3.41 μ s	10.38 μ s	10.51 μ s
Edge Controlled Exposure	3.33 μ s	3.46 μ s	10.73 μ s	10.86 μ s
Level Controlled Exposure	3.28 μ s	3.41 μ s	10.38 μ s	10.51 μ s
	Time Delayed Line Summing and Time Delayed Line Averaging Acquisition Modes - 40 MHz			
	Without Horizontal Binning		With Horizontal Binning	
	Min.	Max.	Min.	Max.
Programmable	3.33 μ s	3.46 μ s	10.43 μ s	10.56 μ s
Edge Controlled Exposure	3.38 μ s	3.51 μ s	10.78 μ s	10.91 μ s
Level Controlled Exposure	3.33 μ s	3.46 μ s	10.43 μ s	10.56 μ s
	Single Line Acquisition Mode - 80 MHz			
	Without Horizontal Binning		With Horizontal Binning	
	Min.	Max.	Min.	Max.
Programmable	9.51 μ s	9.61 μ s	13.41 μ s	13.51 μ s
Edge Controlled Exposure	9.86 μ s	9.96 μ s	13.76 μ s	13.86 μ s
Level Controlled Exposure	9.51 μ s	9.61 μ s	13.41 μ s	13.51 μ s
	Time Delayed Line Summing and Time Delayed Line Averaging Acquisition Modes - 80 MHz			
	Without Horizontal Binning		With Horizontal Binning	
	Min.	Max.	Min.	Max.
Programmable	9.53 μ s	9.64 μ s	13.43 μ s	13.54 μ s
Edge Controlled Exposure	9.88 μ s	9.99 μ s	13.78 μ s	13.89 μ s
Level Controlled Exposure	9.53 μ s	9.64 μ s	13.43 μ s	13.54 μ s

Table 20: Line Valid Delay with the 8k Camera Set for a 4 Tap Video Data Output Mode

5.2.3 8 Tap 8 Bit Output Mode

In 8 tap 8 bit output mode, on each pixel clock cycle, the camera transmits data for eight pixels at 8 bit depth, a line valid bit and a data valid bit.

In the 8 tap output mode, the camera uses the output ports on Camera Link Transmitters X, Y and Z to transmit pixel data, a line valid bit, a data valid bit, and the Camera Link pixel clock. The assignment of the bits to the output ports on Camera Link Transmitters X, Y and Z is as shown in Table 21 on [page 107](#), Table 22 on [page 108](#), and Table 23 on [page 109](#) respectively.

The Camera Link clock is used to time the transmission of acquired pixel data. As shown in Figure 39 on [page 110](#) and Figure 40 on [page 111](#), the camera samples and transmits data on each rising edge of the Camera Link clock. The Camera Link pixel clock frequency is as stated in Section 2.8.4 on [page 35](#).

The line valid bit indicates that a valid line is being transmitted. The data valid bit indicates that valid pixel data is being transmitted. Pixel data is only valid when the line valid and data valid bits are both high.



Note

The video data output mode that you select may affect the camera's maximum allowed line rate. See Section 4.3 on [page 74](#).

The data sequence outlined below, along with Figure 39 on [page 110](#) and Figure 40 on [page 111](#), describes what is happening at the inputs to the Camera Link transmitters in the camera.

5.2.3.1 Video Data Sequence for 8 Tap 8 Bit Mode

When the camera is not transmitting valid data, the line valid and data valid bits sent on each cycle of the pixel clock will be low. After the camera has completed a line acquisition, it will begin to send data:

- On the clock cycle where valid pixel data transmission begins, the line valid and data valid bits both become high. Eight data streams, D0 through D7 are transmitted in parallel during this clock cycle. On this clock cycle, data stream D0 will transmit data for pixel 1 in the line. Data stream D1 will transmit data for pixel 2. Data stream D2 will transmit data for pixel 3. Data stream D3 will transmit data for pixel 4. Data stream D4 will transmit data for pixel 5. Data stream D5 will transmit data for pixel 6. Data stream D6 will transmit data for pixel 7. And data stream D7 will transmit data for pixel 8. The pixel data will be at 8 bit depth.
- On the next cycle of the pixel clock, the line valid and data valid bits will both be high. On this clock cycle, data stream D0 will transmit data for pixel 9 in the line. Data stream D1 will transmit data for pixel 10. Data stream D2 will transmit data for pixel 11. Data stream D3 will transmit data for pixel 12. Data stream D4 will transmit data for pixel 13. Data stream D5 will transmit data for pixel 14. Data stream D6 will transmit data for pixel 15. And data stream D7 will transmit data for pixel 16. The pixel data will be at 8 bit depth.
- On the next cycle of the pixel clock, the line valid and data valid bits will both be high. On this clock cycle, data stream D0 will transmit data for pixel 17 in the line. Data stream D1 will

transmit data for pixel 18. Data stream D2 will transmit data for pixel 19. Data stream D3 will transmit data for pixel 20. Data stream D4 will transmit data for pixel 21. Data stream D5 will transmit data for pixel 22. Data stream D6 will transmit data for pixel 23. And data stream D7 will transmit data for pixel 24. The pixel data will be at 8 bit depth.

- This pattern will continue until all of the pixel data for line one has been transmitted.
- After all of the pixel data for the line has been transmitted, the line valid and data valid bits both become low indicating that valid pixel data is no longer being transmitted.

Figure 39 on [page 110](#) shows the data sequence when the camera is operating in edge-controlled or level-controlled exposure mode. Figure 40 on [page 111](#) shows the data sequence when the camera is operating in programmable exposure mode.

MDR Conn. 1, Transmitter X			
Port	Camera	Frame Grabber	Bit Assignment
			8 Tap -8 Bit
Port A0	TxIN0	RxOut0	D0 Bit 0
Port A1	TxIN1	RxOut1	D0 Bit 1
Port A2	TxIN2	RxOut2	D0 Bit 2
Port A3	TxIN3	RxOut3	D0 Bit 3
Port A4	TxIN4	RxOut4	D0 Bit 4
Port A5	TxIN6	RxOut6	D0 Bit 5
Port A6	TxIN27	RxOut27	D0 Bit 6
Port A7	TxIN5	RxOut5	D0 Bit 7 (MSB)
Port B0	TxIN7	RxOut7	D1 Bit 0
Port B1	TxIN8	RxOut8	D1 Bit 1
Port B2	TxIN9	RxOut9	D1 Bit 2
Port B3	TxIN12	RxOut12	D1 Bit 3
Port B4	TxIN13	RxOut13	D1 Bit 4
Port B5	TxIN14	RxOut14	D1 Bit 5
Port B6	TxIN10	RxOut10	D1 Bit 6
Port B7	TxIN11	RxOut11	D1 Bit 7 (MSB)
Port C0	TxIN15	RxOut15	D2 Bit 0
Port C1	TxIN18	RxOut18	D2 Bit 1
Port C2	TxIN19	RxOut19	D2 Bit 2
Port C3	TxIN20	RxOut20	D2 Bit 3
Port C4	TxIN21	RxOut21'	D2 Bit 4
Port C5	TxIN22	RxOut22	D2 Bit 5
Port C6	TxIN16	RxOut16	D2 Bit 6
Port C7	TxIN17	RxOut17	D2 Bit 7 (MSB)
LVAL	TxIN24	RxOut24	Line Valid
FVAL	TxIN25	RxOut25	Not Used
DVAL	TxIN26	RxOut26	Data Valid
Spare	TxIN23	RxOut23	Not Used
Strobe	TxINCLK	RxOutClk	Pixel Clock

Table 21: Bit Assignments for 8 Tap Output Mode (MDR Conn 1 - Transmitter X)

MDR Conn 2, Transmitter Y			
Port	Camera	Frame Grabber	Bit Assignment
			8 Tap - 8 Bit
Port D0	TxIN0	RxOut0	D3 Bit 0
Port D1	TxIN1	RxOut1	D3 Bit 1
Port D2	TxIN2	RxOut2	D3 Bit 2
Port D3	TxIN3	RxOut3	D3 Bit 3
Port D4	TxIN4	RxOut4	D3 Bit 4
Port D5	TxIN6	RxOut6	D3 Bit 5
Port D6	TxIN27	RxOut27	D3 Bit 6
Port D7	TxIN5	RxOut5	D3 Bit 7 (MSB)
Port E0	TxIN7	RxOut7	D4 Bit 0
Port E1	TxIN8	RxOut8	D4 Bit 1
Port E2	TxIN9	RxOut9	D4 Bit 2
Port E3	TxIN12	RxOut12	D4 Bit 3
Port E4	TxIN13	RxOut13	D4 Bit 4
Port E5	TxIN14	RxOut14	D4 Bit 5
Port E6	TxIN10	RxOut10	D4 Bit 6
Port E7	TxIN11	RxOut11	D4 Bit 7 (MSB)
Port F0	TxIN15	RxOut15	D5 Bit 0
Port F1	TxIN18	RxOut18	D5 Bit 1
Port F2	TxIN19	RxOut19	D5 Bit 2
Port F3	TxIN20	RxOut20	D5 Bit 3
Port F4	TxIN21	RxOut21'	D5 Bit 4
Port F5	TxIN22	RxOut22	D5 Bit 5
Port F6	TxIN16	RxOut16	D5 Bit 6
Port F7	TxIN17	RxOut17	D5 Bit 7 (MSB)
LVAL	TxIN24	RxOut24	Line Valid
FVAL	TxIN25	RxOut25	Not Used
DVAL	TxIN26	RxOut26	Data Valid
Spare	TxIN23	RxOut23	Not Used
Strobe	TxINCLK	RxOutClk	Pixel Clock

Table 22: Bit Assignments for 8 Tap Output Mode (MDR Conn 2 - Transmitter Y)

MDR Conn 2, Transmitter Z			
Port	Camera	Frame Grabber	Bit Assignment
			8 Tap - 8 Bit
Port G0	TxIN0	RxOut0	D6 Bit 0
Port G1	TxIN1	RxOut1	D6 Bit 1
Port G2	TxIN2	RxOut2	D6 Bit 2
Port G3	TxIN3	RxOut3	D6 Bit 3
Port G4	TxIN4	RxOut4	D6 Bit 4
Port G5	TxIN6	RxOut6	D6 Bit 5
Port G6	TxIN27	RxOut27	D6 Bit 6
Port G7	TxIN5	RxOut5	D6 Bit 7 (MSB)
Port H0	TxIN7	RxOut7	D7 Bit 0
Port H1	TxIN8	RxOut8	D7 Bit 1
Port H2	TxIN9	RxOut9	D7 Bit 2
Port H3	TxIN12	RxOut12	D7 Bit 3
Port H4	TxIN13	RxOut13	D7 Bit 4
Port H5	TxIN14	RxOut14	D7 Bit 5
Port H6	TxIN10	RxOut10	D7 Bit 6
Port H7	TxIN11	RxOut11	D7 Bit 7
Spare	TxIN15	RxOut15	Not Used
Spare	TxIN18	RxOut18	Not Used
Spare	TxIN19	RxOut19	Not Used
Spare	TxIN20	RxOut20	Not Used
Spare	TxIN21	RxOut21'	Not Used
Spare	TxIN22	RxOut22	Not Used
Spare	TxIN16	RxOut16	Not Used
Spare	TxIN17	RxOut17	Not Used
LVAL	TxIN24	RxOut24	Line Valid
FVAL	TxIN25	RxOut25	Not Used
DVAL	TxIN26	RxOut26	Data Valid
Spare	TxIN23	RxOut23	Not Used
Strobe	TxINCLK	RxOutClk	Pixel Clock

Table 23: Bit Assignments for 8 Tap Output Mode (MDR Conn 2 - Transmitter Z)

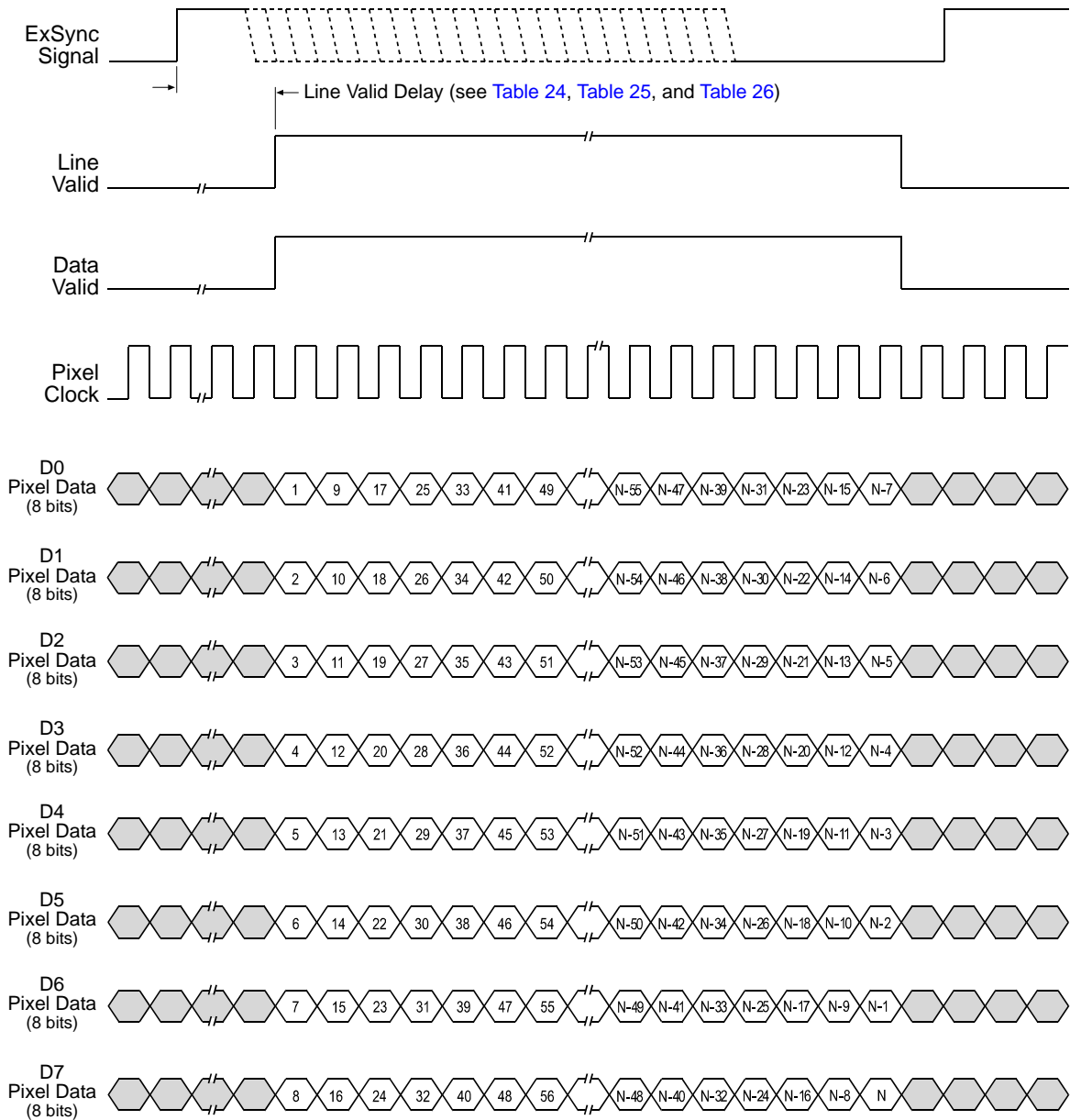

Timing diagrams are not to scale.

N = At full resolution without horizontal binning enabled, N = 8192 on 8k models, 4096 on 4k models, and 2048 on 2k models

N = At full resolution with horizontal binning enabled, N = 4096 on 8k models, 2048 on 4k models, and 1024 on 2k models

If the AOI feature is used, N will be determined by the AOI settings

Fig. 39: Eight Tap Modes with Edge or Level Controlled Exposure

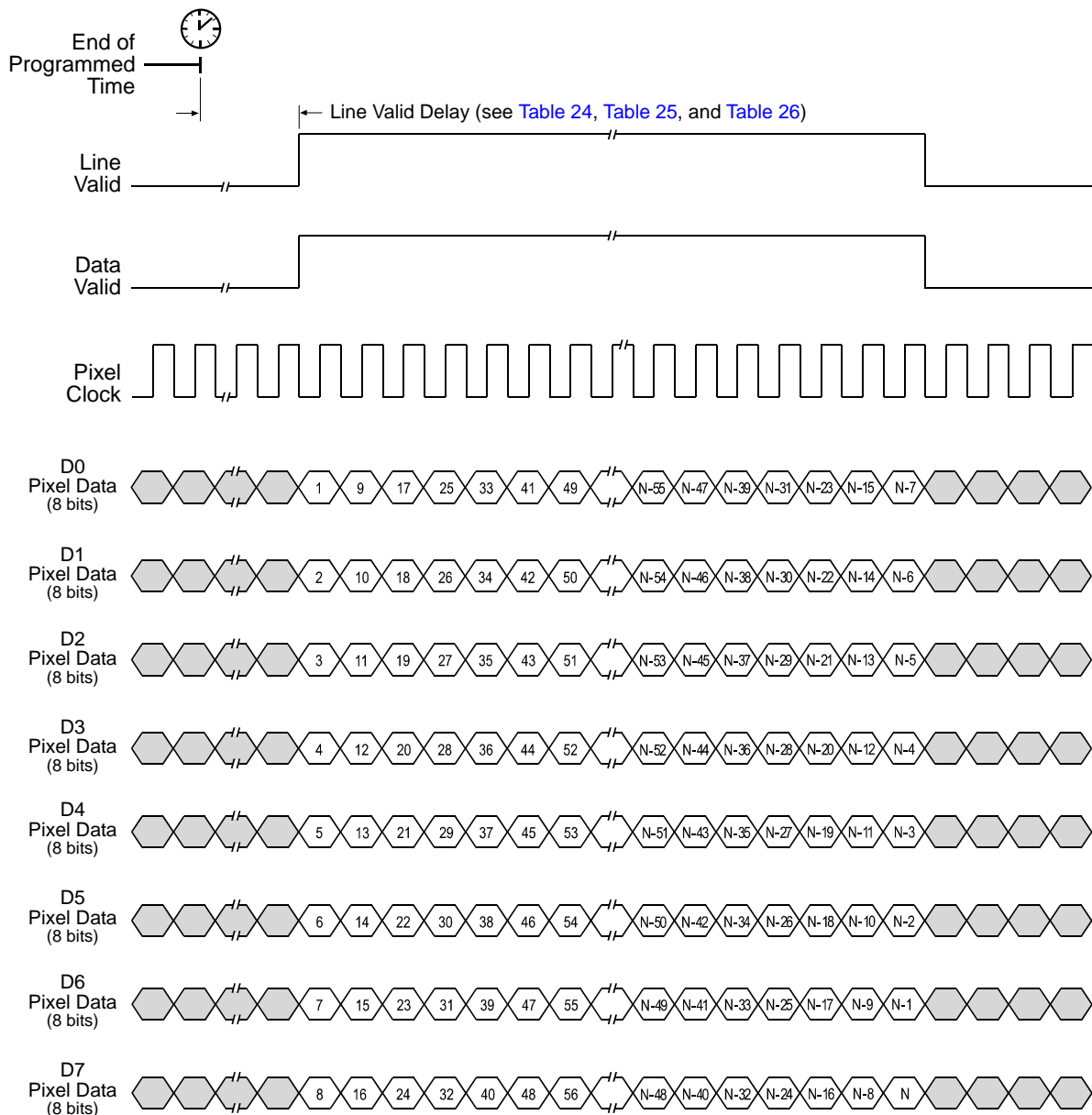

Timing diagrams are not to scale.

N = At full resolution without horizontal binning enabled, N = 8192 on 8k models, 4096 on 4k models, and 2048 on 2k models

N = At full resolution with horizontal binning enabled, N = 4096 on 8k models, 2048 on 4k models, and 1024 on 2k models

If the AOI feature is used, N will be determined by the AOI settings

Fig. 40: Eight Tap Mode with Programmable Exposure

5.2.3.2 Line Valid Delays for 8 Tap Output Modes

The table below shows the line valid delay (see Figure 39 on [page 110](#) and Figure 40 on [page 111](#)) when the camera is set for full resolution and an 8 tap video data output mode. Note that the delay depends on the line acquisition mode setting, the Camera Link clock speed, and whether horizontal binning is enabled. The delay also depends on whether the camera is a 2k, 4k, or 8k camera.

Each line delay can vary slightly within the stated minimum and maximum delays.

2k Cameras

Line Valid Delays for 8 Tap Modes - 2k Cameras				
	Single Line, Time Delayed Line Summing, and Time Delayed Line Averaging Acquisition Modes - 40 MHz			
	Without Horizontal Binning		With Horizontal Binning	
	Min.	Max.	Min.	Max.
Programmable	9.58 μ s	9.71 μ s	13.35 μ s	13.48 μ s
Edge Controlled Exposure	9.93 μ s	10.06 μ s	13.70 μ s	13.83 μ s
Level Controlled Exposure	9.58 μ s	9.71 μ s	13.35 μ s	13.48 μ s
	Dual Line Acquisition Modes - 40 MHz			
	Without Horizontal Binning		With Horizontal Binning	
	Min.	Max.	Min.	Max.
Programmable	9.56 μ s	9.71 μ s	13.31 μ s	13.46 μ s
Edge Controlled Exposure	9.56 μ s	9.71 μ s	13.31 μ s	13.46 μ s
Level Controlled Exposure	9.56 μ s	9.71 μ s	13.31 μ s	13.46 μ s
	Single Line, Time Delayed Line Summing, and Time Delayed Line Averaging Acquisition Modes - 80 MHz			
	Without Horizontal Binning		With Horizontal Binning	
	Min.	Max.	Min.	Max.
Programmable	12.60 μ s	12.70 μ s	14.77 μ s	14.88 μ s
Edge Controlled Exposure	12.95 μ s	13.05 μ s	15.12 μ s	15.23 μ s
Level Controlled Exposure	12.60 μ s	12.70 μ s	14.77 μ s	14.88 μ s
	Dual Line Acquisition Modes - 80 MHz			
	Without Horizontal Binning		With Horizontal Binning	
	Min.	Max.	Min.	Max.
Programmable	12.58 μ s	12.70 μ s	14.76 μ s	14.88 μ s
Edge Controlled Exposure	12.58 μ s	12.70 μ s	14.76 μ s	14.88 μ s
Level Controlled Exposure	12.58 μ s	12.70 μ s	14.76 μ s	14.88 μ s

Table 24: Line Valid Delay with the 2k Camera Set for a 8 Tap Video Data Output Mode

4k Cameras

Line Valid Delays for 8 Tap Modes - 4k Cameras				
	Single Line, Time Delayed Line Summing, and Time Delayed Line Averaging Acquisition Modes - 40 MHz			
	Without Horizontal Binning		With Horizontal Binning	
	Min.	Max.	Min.	Max.
Programmable	9.64 μ s	9.76 μ s	13.44 μ s	13.56 μ s
Edge Controlled Exposure	9.99 μ s	10.11 μ s	13.79 μ s	13.91 μ s
Level Controlled Exposure	9.64 μ s	9.76 μ s	13.44 μ s	13.56 μ s
	Dual Line Acquisition Modes - 40 MHz			
	Without Horizontal Binning		With Horizontal Binning	
	Min.	Max.	Min.	Max.
Programmable	9.62 μ s	9.76 μ s	13.42 μ s	13.56 μ s
Edge Controlled Exposure	9.62 μ s	9.76 μ s	13.42 μ s	13.56 μ s
Level Controlled Exposure	9.62 μ s	9.76 μ s	13.42 μ s	13.56 μ s
	Single Line, Time Delayed Line Summing, and Time Delayed Line Averaging Acquisition Modes - 80 MHz			
	Without Horizontal Binning		With Horizontal Binning	
	Min.	Max.	Min.	Max.
Programmable	12.65 μ s	12.75 μ s	14.88 μ s	14.97 μ s
Edge Controlled Exposure	13.00 μ s	13.10 μ s	15.23 μ s	14.32 μ s
Level Controlled Exposure	12.65 μ s	12.75 μ s	14.88 μ s	14.97 μ s
	Dual Line Acquisition Modes - 80 MHz			
	Without Horizontal Binning		With Horizontal Binning	
	Min.	Max.	Min.	Max.
Programmable	12.64 μ s	12.75 μ s	14.86 μ s	14.98 μ s
Edge Controlled Exposure	12.64 μ s	12.75 μ s	14.86 μ s	14.98 μ s
Level Controlled Exposure	12.64 μ s	12.75 μ s	14.86 μ s	14.98 μ s

Table 25: Line Valid Delay with the 4k Camera Set for a 8 Tap Video Data Output Mode

8k Cameras

Line Valid Delays for 8 Tap Modes - 8k Cameras				
	Single Line, Time Delayed Line Summing, and Time Delayed Line Averaging Acquisition Modes - 40 MHz			
	Without Horizontal Binning		With Horizontal Binning	
	Min.	Max.	Min.	Max.
Programmable	9.68 μ s	9.81 μ s	13.58 μ s	13.71 μ s
Edge Controlled Exposure	10.03 μ s	10.16 μ s	13.93 μ s	14.06 μ s
Level Controlled Exposure	9.68 μ s	9.81 μ s	13.58 μ s	13.71 μ s
	Dual Line Acquisition Modes - 40 MHz			
	Without Horizontal Binning		With Horizontal Binning	
	Min.	Max.	Min.	Max.
Programmable	9.73 μ s	9.86 μ s	13.63 μ s	13.76 μ s
Edge Controlled Exposure	10.08 μ s	10.21 μ s	13.98 μ s	14.11 μ s
Level Controlled Exposure	9.73 μ s	9.86 μ s	13.63 μ s	13.76 μ s
	Single Line, Time Delayed Line Summing, and Time Delayed Line Averaging Acquisition Modes - 80 MHz			
	Without Horizontal Binning		With Horizontal Binning	
	Min.	Max.	Min.	Max.
Programmable	12.71 μ s	12.81 μ s	15.01 μ s	15.11 μ s
Edge Controlled Exposure	13.06 μ s	13.16 μ s	15.36 μ s	15.46 μ s
Level Controlled Exposure	12.71 μ s	12.81 μ s	15.01 μ s	15.11 μ s
	Dual Line Acquisition Modes - 80 MHz			
	Without Horizontal Binning		With Horizontal Binning	
	Min.	Max.	Min.	Max.
Programmable	12.73 μ s	12.84 μ s	15.03 μ s	15.14 μ s
Edge Controlled Exposure	13.08 μ s	13.19 μ s	15.38 μ s	15.49 μ s
Level Controlled Exposure	12.73 μ s	12.84 μ s	15.03 μ s	15.14 μ s

Table 26: Line Valid Delay with the 8k Camera Set for a 8 Tap Video Data Output Mode

6 Features

6.1 Gain and Offset

6.1.1 Gain

Gain is adjustable. As shown in Figure 41, increasing the gain setting increases the slope of the camera's response curve and results in higher camera output for a given amount of light input. Decreasing the gain setting decreases the slope of the response curve and results in lower output for a given amount of light.

Gain is adjustable on an integer scale. The minimum gain setting for all video data output modes is 2731. The maximum setting is 16383, 8192, or 6144 when the camera is set for an 8 bit, 10 bit, or 12 bit video data output mode respectively.

The default setting is 4096 which results in 0 dB of gain.

Table 27 shows the dB of gain that will be achieved at various integer settings.

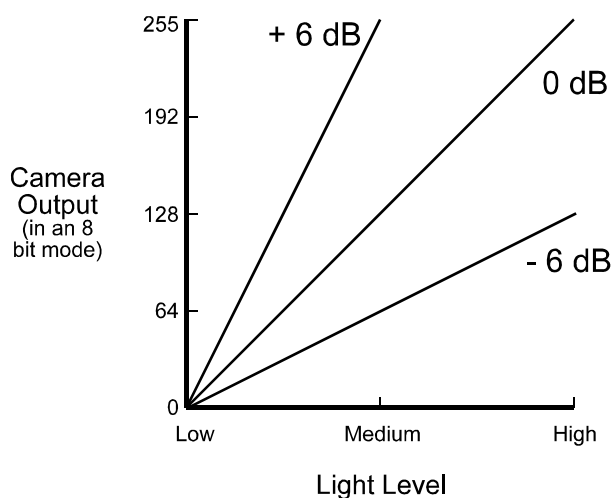

Fig. 41: Various Levels of Gain

Gain Setting	dB of Gain
2731 (minimum allowed for all modes)	- 3.5
4096 (default)	0
6144 (maximum allowed for 12 bit modes)	+ 3.5
8192 (maximum allowed for 10 bit modes)	+ 6.0
16383 (maximum allowed for 8 bit modes)	+ 12.0

Table 27: dB of Gain at Various Settings

If you know the integer setting for the gain, you can calculate the resulting dB of gain that the camera will achieve by using the following formula:

$$\text{Gain in dB} = 20 \times \log_{10} \left(\frac{\text{setting}}{4096} \right)$$

Setting the Gain

You can set the gain with the Camera Configuration Tool Plus (CCT+) or by using binary write commands from within your own application to set the camera's control and status registers (CSRs).

With the CCT+

With the CCT+ (see Section 7.1 on [page 156](#)), you use the Gain parameter in the Gain & Offset parameters group to set the gain.

By Setting CSRs

You set the gain by writing a value in dB to the Absolute Gain field or by writing an integer value to the Raw Gain field of the Gain CSR (see [page 173](#)).

Section 7.2.2 on [page 164](#) explains CSRs and the difference between using the "absolute" field and the "raw" field in a CSR. Section 7.3.1 on [page 197](#) explains using read/write commands.

6.1.2 Offset

Offset is adjustable on an integer scale that ranges from -4095 to +4095. The default setting is 0.

If the camera is set for an 8 bit video data output mode:

- increasing the integer offset setting by 16 will increase the digital pixel values output from the camera by 1.
- decreasing the integer offset setting by 16 will decrease the digital pixel values output from the camera by 1.

If the camera is set for a 10 bit video data output mode:

- increasing the integer offset setting by 4 will increase the digital pixel values output from the camera by 1.
- decreasing the integer offset setting by 4 will decrease the digital pixel values output from the camera by 1.

If the camera is set for a 12 bit video data output mode:

- increasing the integer offset setting by 1 will increase the digital pixel values output from the camera by 1.
- decreasing the integer offset setting by 1 will decrease the digital pixel values output from the camera by 1.

Setting the Offset

You can set the offset with the Camera Configuration Tool Plus (CCT+) or by using binary write commands from within your own application to set the camera's control and status registers (CSRs).

With the CCT+

With the CCT+ (see Section 7.1 on [page 156](#)), you use the Offset parameter in the Gain & Offset parameters group to set the offset.

By Setting CSRs

You set the offset by writing a value in digital numbers to the Absolute Offset field or by writing an integer value to the Raw Offset field of the Offset CSR (see [page 174](#)).

Section 7.2.2 on [page 164](#) explains CSRs and the difference between using the "absolute" field and the "raw" field in a CSR. Section 7.3.1 on [page 197](#) explains using read/write commands.

6.2 Area of Interest

The area of interest feature lets you specify a portion of the sensor lines. During operation, only the pixel information from the specified portion of the lines is read out of the sensor and transmitted from the camera to the frame grabber.

The size of the area of interest is defined by declaring a starting pixel and a length in pixels. For example, if you specify the starting pixel as 33 and the length in pixels as 256, the camera will readout and transmit pixel values for pixels 33 through 288 as shown in Figure 42.

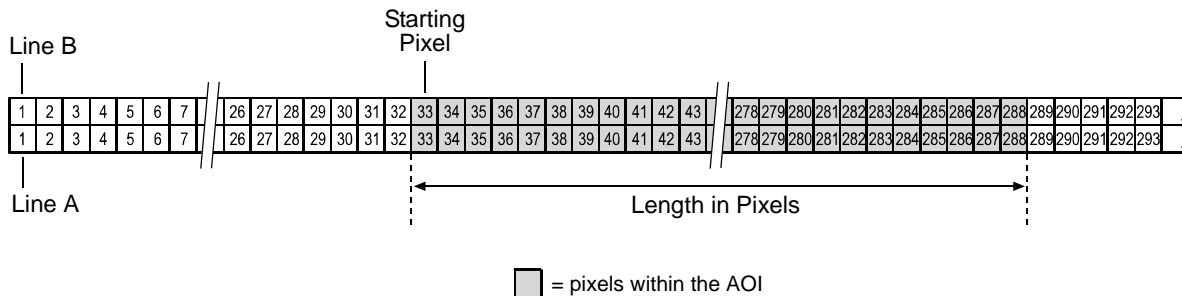

Fig. 42: Area of Interest

If you are operating the camera in single line acquisition mode, the AOI applies to line A. In all other line acquisition modes, the AOI applies to both line A and line B. For more information about line acquisition modes, see Chapter 3 on [page 39](#).

When setting the AOI, the following guidelines apply:

- The AOI Starting Pixel can be set to 1 and can be increased in increments of 32.

- The AOI Length must be a minimum of 256 pixels can be increased in increments of 32.

- The AOI Starting Pixel + AOI Length \leq Number of Pixels in Each Sensor Line + 1.

For example, if you are working with a camera that has 2048 pixels in each sensor line:

- The AOI Starting Pixel can be set to 1, 33, 65, 97, etc.

- The AOI Length can be set to 256, 288, 320, 352, etc.

- The AOI Starting Pixel + AOI Length \leq 2049.

If you are working with a camera that has 4096 pixels in each sensor line:

- The AOI Starting Pixel can be set to 1, 33, 65, 97, etc.

- The AOI Length can be set to 256, 288, 320, 352, etc.

- The AOI Starting Pixel + AOI Length \leq 4097.

If you are working with a camera that has 8192 pixels in each sensor line:

- The AOI Starting Pixel can be set to 1, 33, 65, 97, etc.

- The AOI Length can be set to 256, 288, 320, 352, etc.

- The AOI Starting Pixel + AOI Length \leq 8193.

When the area of interest feature is used, the maximum allowed line rate may increase. For more information about the impact of the AOI settings on the maximum allowed line rate, see Section 4.3 on [page 74](#).

Using the AOI Feature with Horizontal Binning Enabled

If the camera's horizontal binning feature (see Section 3.8 on [page 59](#)) is enabled, it will have an effect on the way that you set up the area of interest. With horizontal binning enabled, pairs of adjacent pixel in a line are binned together into a single pixel. When you set an AOI with horizontal binning enabled, the AOI settings are based on "binned" pixels rather than the actual physical pixels in the sensor lines.

If you are working with a camera that has sensor lines with 2048 physical pixels and you enable horizontal binning, you effectively reduce the resolution to 1024 "binned" pixels. In this case, you would set the AOI as if you were working with a sensor that actually has 1024 pixels and the guidelines for working with this situation would be:

- The AOI Starting Pixel can be set to 1 and can be increased in increments of 16 (e.g., it can be set to 1, 17, 33, etc.).

- The AOI Length must be a minimum of 128 pixels can be increased in increments of 16 (e.g., the length can be set to 128, 144, 160, etc.).

- The AOI Starting Pixel + AOI Length \leq 1025.

If you are working with a camera that has sensor lines with 4096 physical pixels and you enable horizontal binning, you effectively reduce the resolution to 2048 "binned" pixels. In this case, you would set the AOI as if you were working with a sensor that actually has 2048 pixels and the guidelines for working with this situation would be:

- The AOI Starting Pixel can be set to 1 and can be increased in increments of 16 (e.g., it can be set to 1, 17, 33, etc.).

- The AOI Length must be a minimum of 128 pixels can be increased in increments of 16 (e.g., the length can be set to 128, 144, 160, etc.).

- The AOI Starting Pixel + AOI Length \leq 2049.

If you are working with a camera that has sensor lines with 8192 physical pixels and you enable horizontal binning, you effectively reduce the resolution to 4096 "binned" pixels. In this case, you would set the AOI as if you were working with a sensor that actually has 4096 pixels and the guidelines for working with this situation would be:

- The AOI Starting Pixel can be set to 1 and can be increased in increments of 16 (e.g., it can be set to 1, 17, 33, etc.).

- The AOI Length must be a minimum of 128 pixels can be increased in increments of 16 (e.g., the length can be set to 128, 144, 160, etc.).

- The AOI Starting Pixel + AOI Length \leq 4097.

6.2.1 Setting the AOI

You can set the AOI with the Camera Configuration Tool Plus (CCT+) or by using binary write commands from within your own application to set the camera's control and status registers (CSRs).

With the CCT+

With the CCT+ (see Section 7.1 on [page 156](#)), you use the AOI Starting Pixel parameter and the AOI Length parameter in the AOI parameters group to set the AOI.

By Setting CSRs

You set the AOI starting pixel by writing a value to the Starting Pixel field of the AOI Starting Pixel CSR (see [page 176](#)).

You set the AOI length by writing a value to the Length field of the AOI Length CSR (see [page 177](#)).

See Section 7.2.2 on [page 164](#) for an explanation of CSRs and Section 7.3.1 on [page 197](#) for an explanation of using read/write commands.

6.3 Shading Correction

In theory, when a digital camera captures an image of a uniform object, the pixel values output from the camera should be uniform. In practice, however, variations in optics and lighting and small variations in the sensor's performance can cause the camera output to be non-uniform even when it is capturing images of a uniform object. The camera is equipped with a shading correction feature that allows it to correct the captured image for variations caused by optics, lighting, and sensor variations. There are two types of shading correction available on the camera, DSNU shading correction and PRNU shading correction. You can set the camera to do only DSNU correction, to do only PRNU correction, or to do both types of correction.

DSNU Shading Correction

When a line scan camera with a digital sensor captures a line in complete darkness, all of the pixel values in the line should be near zero and they should be equal. In practice, slight variations in the performance of the pixels in the sensor will cause some variation in the pixel values output from the camera when the camera is capturing lines in darkness. This type of variation is known as Dark Signal Non-uniformity (DSNU). DSNU shading correction corrects for the variations caused by DSNU.

PRNU Shading Correction

When a line scan camera with a digital sensor captures a line with the camera viewing a uniform light-colored target in bright light, all of the pixel values in the line should be near their maximum gray value and they should be equal. In practice, slight variations in the performance of the pixels in the sensor, variations in the optics, and variations in the lighting will cause some variation in the pixel values output from the camera. This type of variation is known as Photo Response Non-uniformity (PRNU). The PRNU shading correction feature on the camera can correct for the variations caused by PRNU.

The Factory Shading Value File and the User Shading Value File

To perform DSNU and PRNU shading correction, the camera needs a set of DSNU and PRNU shading correction values. The camera has two files in its nonvolatile memory where it stores the values that it needs to perform shading correction.

The first shading values file is called the "factoryshading" file. This file contains a complete collection of the values needed to perform both DSNU shading correction and PRNU shading correction. The values in this file are generated during the camera's factory setup procedure and they essentially serve as default shading values. The values in the factory file are optimized for performing shading correction with "standard" optics and lighting. Using the factory settings will give you reasonable DSNU and PRNU shading correction performance in most situations. The factory shading values file is in a protected area of the camera's memory and can't be changed. One advantage of the factory values is that they serve as a good default.

The second shading values file is called the "usershading" file. This file can also hold a complete collection of the values needed to perform both DSNU and PRNU shading correction. The values stored in this file must be generated by the camera user while the camera is operating under its real world conditions. This file contains the shading values that will normally be used for day-to-day camera operation. A procedure describing how to generate the values in this file appears on the next page.)

Guidelines When Using Shading Correction

When using the shading correction feature, make sure to take the following guidelines into account:

- Any time you make a change to the optics or lighting or if you change the camera's exposure mode or exposure time, you must generate a new set of user PRNU shading values. Using out of date PRNU shading values can result in poor image quality.

6.3.1 Enabling Shading Correction

You can enable shading correction with the Camera Configuration Tool Plus (CCT+) or by using binary read/write commands from within your own application to set the camera's control and status registers (CSRs).

With the CCT+

With the CCT+ (see Section 7.1 on [page 156](#)), you use the Shading Mode parameter in the DSNU and PRNU Shading Correction parameters group to enable shading correction. You can enable, DRNU correction only, PRNU correction only, or both DRNU and PRNU correction.

By Setting CSRs

You enable shading correction by writing the appropriate value to the Mode field of the Shading Mode CSR (see [page 178](#)).

Section 7.2.2 on [page 164](#) explains CSRs and Section 7.3.1 on [page 197](#) explains using read/write commands.

6.3.2 Generating and Saving User Shading Correction Values

This section includes procedures for generating the user DSNU and PRNU shading correction values that will be stored in the user shading correction values file. If you will be setting the camera to do DSNU correction only, then you only need to perform the DSNU procedure. If you will be setting the camera to do PRNU correction only, then you only need to perform the PRNU procedure. And if you will be setting the camera to do both DSNU and PRNU correction, you must follow both procedures.

Generating and Saving User DSNU Shading Correction Values

The procedure below describes how to generate user DSNU shading correction values. When you generate the values, they will automatically be stored in the camera's user shading value file.

You should be aware that the camera uses one set of DSNU values when it is operating in single line acquisition mode and a different set of values when it is operating in any one of the other line acquisition modes (see Chapter 3 on [page 39](#) for more information about line acquisition modes). This means that:

- If you will always be operating the camera in single line acquisition mode, you should set the camera for single line acquisition mode and then follow the steps below one time.
- If you will never be operating the camera in single line acquisition mode, you should set the camera for any one of the other acquisition modes and then follow the steps below one time.
- If you will sometimes operate the camera in single line acquisition mode and other times operate the camera in one of the other modes, you should first set the camera for single line acquisition mode and follow the steps below. You should then, set the camera for any one of the other acquisition modes and you should go through the steps a second time.

(The camera's user shading values file has one area where it holds the DSNU values it uses for single line mode and another area where it stores the values for all of the other modes.)

To generate a set of user DSNU values:

1. Set the camera for the desired line acquisition mode.
2. Make sure the area of interest parameters are set so that the camera will use the full length of the sensor (see Section 6.2 on [page 118](#)).
3. Ensure that the camera will be capturing lines in complete darkness by covering the camera lens, closing the iris in the lens, or darkening the room.
4. Begin acquiring lines either by generating an ExSync signal to trigger line acquisition or by setting the camera for a free run exposure time control mode.
5. Signal the camera to generate a set of DSNU values:
 - a. You can start the generation of a set of DSNU values with the Camera Configuration Tool Plus (see Section 7.1 on [page 156](#)). With the CCT+, set the value of the Generate parameter in the DSNU & PRNU Shading Correction parameters group to Generate DSNU Values.

- b. You can also start the generation of a set of DSNU values by using a binary write command (see Section 7.3 on [page 196](#)) to write a value to the Generate field of the Shading Value Generate CSR (see [page 178](#)).
6. The camera must make at least 64 acquisitions to create a set of DSNU shading correction values. If your camera is set to control exposure with an ExSync signal, you must generate at least 64 ExSync signal cycles after you signal the camera to begin generating the values. If you are running the camera in a free run exposure time control mode, you must wait long enough for the camera to complete at least 64 acquisitions.
 - a. When the camera is acquiring the lines it needs to create the DSNU shading values, the line valid and data valid signals will go high and low as you would normally expect. However, the data in these lines is not useful to you and should be ignored.

**Note**

If you started the generation of the shading values using the CCT+, you are using an ExSync signal to trigger acquisitions, and you are operating the camera at a line period greater than approximately 300 ms, you should be aware of a potential problem. Under these conditions, the CCT+ may time out while it is waiting for the camera to complete 64 acquisitions and you may see a “Camera is not responding ...” error message. This error is not fatal to the shading value creation process. If you close the error message window, wait several seconds and then click the Refresh button on the CCT+, the shading values will be properly created.

If you started the generation of the shading values using binary commands, you are using an ExSync signal to trigger acquisitions, and you are operating the camera at very low line rates, you should be aware of a restriction. The camera will not acknowledge or respond to binary commands while it is performing the 64 acquisitions needed to create a set of shading values. Once you have issued the binary command to start generating shading values, you should wait until the generation process is complete before you issue any further binary commands. The time needed to complete the generation process will be equal to 64 times the line period.

7. Once 64 acquisitions have been completed, the camera calculates the DSNU values:
 - a. The camera uses the data from the 64 acquisitions to calculate an average gray value for the pixels in each line.
 - b. The camera finds the pixel with the highest average gray value in each line.
 - c. For each of the other pixels in the line, the camera determines the offset that would be needed to make the pixel’s average value equal to the average value for the highest pixel.
 - d. The camera generates a set of DSNU shading values that contains the calculated offsets.
8. The generated set of DSNU values is automatically saved in the user shading values file in the camera’s non-volatile memory. Existing values in the file will be overwritten.
9. The user shading value file is automatically "activated." See Section 6.3.3 on [page 128](#) for more information about what it means to activate a shading file.

Generating and Saving User PRNU Shading Correction Values

The procedure below describes how to generate user PRNU shading correction values. When you generate the values, they will automatically be stored in the camera's user shading value file.

You should be aware that the camera uses one set of PRNU values when it is operating in single line acquisition mode and a different set of values when it is operating in any one of the other line acquisition modes (see Chapter 3 on [page 39](#) for more information about line acquisition modes). This means that:

- If you will always be operating the camera in single line acquisition mode, you should set the camera for single line acquisition mode and then follow the steps below one time.
- If you will never be operating the camera in single line acquisition mode, you should set the camera for any one of the other acquisition modes and then follow the steps below one time.
- If you will sometimes operate the camera in single line acquisition mode and other times operate the camera in one of the other modes, you should first set the camera for single line acquisition mode and follow the steps below. You should then, set the camera for any one of the other acquisition modes and you should go through the steps a second time.

(The camera's user shading values file has one area where it holds the PRNU values it uses for single line mode and another area where it stores the values for all of the other modes.)

To generate a set of user PRNU values:

1. Place a uniform white or light colored target in the field of view of the camera. Adjust your lighting, optics, line rate, exposure mode, exposure time, gain and camera temperature as you would for normal system operation.
2. Set the camera for the desired line acquisition mode.
3. Make sure the area of interest parameters are set so that the camera will use the full length of the sensor (see Section 6.2 on [page 118](#)).
4. Perform several acquisitions and examine the pixel values returned from the camera. The pixel values for the brightest pixels should be about 80 to 85% of maximum.
 - a. If the pixel values for the brightest pixels are at 80 to 85% of maximum, go on to step 3.
 - b. If the pixel values for the brightest pixels are not at 80 to 85% of maximum adjust your lighting and/or lens aperture setting to achieve 80 to 85%.
5. Perform several acquisitions and examine the pixel values in each line. In each line, the values for the darkest pixels must be at least 67% of the values for the lightest pixels in the line. (If the values for the darkest pixels are less than 67% of the value for the lightest pixels, the camera will not be able to fully correct for shading variations.)
 - a. If the values for the darkest pixels are at least 67% of the value for the lightest pixels, go on to step 4.
 - b. If the values for the darkest pixels are less than 67% of the value for the lightest pixels, it usually indicates extreme variations in lighting or poor quality optics. Make corrections as required.

6. Begin acquiring lines either by generating an ExSync signal to trigger line capture or by setting the camera for a free run exposure time control mode.

**Note**

When you generate the PRNU values in the step below, you will have two options:

1. You can generate the PRNU values without using DSNU shading correction. If you do this the pixel values used to calculate the PRNU correction values will not be corrected for DSNU.
2. You can generate the PRNU values with using DSNU shading correction. If you do this the pixel values used to calculate the PRNU correction values will be corrected for DSNU. (For this option to work correctly, you must have already generated DSNU values before you generate the PRNU values.)

7. Signal the camera to generate a set of PRNU values:
 - a. You can start the generation of a set of PRNU values with the Camera Configuration Tool Plus (see Section 7.1 on [page 156](#)). With the CCT+, set the value of the Generate parameter in the DSNU & PRNU Shading Correction parameters group to Generate PRNU Values or to Generate PRNU Values with DSNU.
 - b. You can also start the generation of a set of PRNU values by using a binary write command (see Section 7.3 on [page 196](#)) to write a value to the Generate field of the Shading Value Generate CSR (see [page 178](#)).
8. The camera must make at least 128 acquisitions to generate a set of PRNU values. If your camera is set to control exposure with an ExSync signal, you must generate at least 128 ExSync signal cycles after you signal the camera to begin generating the values. If you are running the camera in a free run exposure time control mode, you must wait long enough for the camera to complete at least 128 acquisitions.
 - a. When the camera is capturing the lines it needs to create the PRNU shading values, the line valid and data valid signals will go high and low as you would normally expect.

However, the data in these lines is not useful to you and should be ignored.

**Note**

If you started the generation of the shading values using the CCT+, you are using an ExSync signal to trigger acquisitions, and you are operating the camera at a line period greater than approximately 300 ms, you should be aware of a potential problem. Under these conditions, the CCT+ may time out while it is waiting for the camera to complete 128 acquisitions and you may see a “Camera is not responding ...” error message. This error is not fatal to the shading value creation process. If you close the error message window, wait several seconds and then click the Refresh button on the CCT+, the shading values will be properly created.

If you started the generation of the shading values using binary commands, you are using an ExSync signal to trigger acquisitions, and you are operating the camera at very low line rates, you should be aware of a restriction. The camera will not acknowledge or respond to binary commands while it is performing the 128 acquisitions needed to create a set of shading values. Once you have issued the binary command to start generating shading values, you should wait until the generation process is complete before you issue any further binary commands. The time needed to complete the generation process will be equal to 128 times the line period.

9. Once 128 acquisitions have been completed, the camera calculates the PRNU values:
 - a. The camera uses the data from the 128 acquisitions to calculate an average gray value for the pixels in each line.
 - b. The camera finds the pixel with the highest average gray value in the line.
 - c. For each of the other pixels in the line, the camera determines the additional gain that would be needed to make the pixel's average value equal to the average value for the highest pixel.
 - d. The camera generates a set of PRNU values that contains the calculated gain adjustments.
10. The generated set of PRNU values is automatically stored in the user shading values file in the camera's non-volatile memory. Existing values in the file will be overwritten.
11. The user shading value file is automatically "activated." See Section 6.3.3 on [page 128](#) for more information about what it means to activate a shading file.

6.3.3 Activating a Shading Values File

As explained in Section 6.3 on [page 121](#), the camera contains a set of factory determined shading correction values in a file in its non-volatile memory. As explained in Section 6.3.2 on [page 123](#), you can also generate a set of "user" shading values and save them to a separate file in the non-volatile memory.

Assuming that you have generated user shading values, you can choose to "activate" either the user shading values file or the factory shading values file. When you activate a shading values file, two things happen:

- The values from the activated file are immediately copied into the camera's volatile memory. When you have shading correction enabled, the camera uses the shading values in the volatile memory to perform shading correction.
- A link is created between the activated file and the volatile memory. The shading values from the activated file will automatically be copied into the volatile memory whenever the camera is powered up or reset. (Assume, for example, that the user shading values file is the activated file. In this case, when the camera is powered on or reset, the values from the user shading values file will be copied into the volatile memory of the camera and will be used to perform shading correction.)

Activating a Shading Values File

You can activate a shading values file with the Camera Configuration Tool Plus (CCT+) or by using binary read/write commands from within your own application to set the camera's bulk data control and status registers (CSRs).

With the CCT+

With the CCT+ (see Section 7.1 on [page 156](#)), you use the File Name Select parameter to select a shading values file and the Activate button in the Shading Files parameters group to activate the selected file.

By Setting CSRs

You can activate a shading values file by writing values to the shading values bulk data CSR.

Section 7.2.3 on [page 188](#) explains bulk data CSRs and using the bulk data activate process.

Section 7.3.1 on [page 197](#) explains using read/write commands.

6.3.4 Copying the Factory Shading Values into the User Shading Values File

As explained in Section 6.3 on [page 121](#), the camera contains a set of factory determined shading correction values in a file in its non-volatile memory. As explained in Section 6.3.2 on [page 123](#), you can also generate a set of "user" shading values and save them to a separate file in the non-volatile memory.

In some situations, it may be advantageous for you to be able to simply copy the contents of the factory shading values files into the file for user shading values

You can copy the values from the factory file into the user file with the Camera Configuration Tool Plus (CCT+) or by using binary read/write commands from within your own application to set the camera's bulk data control and status registers (CSRs).

With the CCT+

With the CCT+ (see Section 7.1 on [page 156](#)), you use the File Name Select parameter and the Copy button in the Shading Files parameters group to copy the data in the factory shading values file to the user shading values file.

By Setting CSRs

You can copy the data in the factory shading values file to the user shading values file by writing values to the shading values bulk data CSR.

Section 7.2.3 on [page 188](#) explains bulk data CSRs and using the bulk data copy process. Section 7.3.1 on [page 197](#) explains using read/write commands.

6.3.5 Downloading a Shading Values File to Your PC

Once you have generated a set of user shading values in the user shading values file as described in Section 6.12.1 on [page 151](#), you can download the user shading values file to your PC. You can also download the factory shading values file to your PC.

Using the download function together with the upload function that is described on the next page is useful if you want to transfer a user shading values file from one camera to another camera of the same type.

You can download the user or the factory shading values file by using the Camera Configuration Tool Plus (CCT+) or by using binary read/write commands from within your own application to set the camera's control and status registers (CSRs).

With the CCT+

With the CCT+ (see Section 7.1 on [page 156](#)), you use the File Name Select parameter in the Shading Files parameters group to select the user shading values file or the factory shading values file and use the Download button to download the selected file.

By Setting CSRs

You can download the user or the factory shading values file by writing values to the shading values bulk data CSR. Section 7.2.3 on [page 188](#) explains the bulk data CSRs and Section 7.2.3.3 on [page 191](#) explains how to use the CSRs to download a file. Section 7.3.1 on [page 197](#) explains using read/write commands.

6.3.6 Uploading a Shading Values File to Your Camera

Once you have downloaded a user shading values file to your PC as described on the previous page, you can upload the file from your PC to a camera.

Using the download function together with the upload function is useful if you want to transfer a user shading values file from one camera to another camera of the same type.

You can upload a user shading values file by using the Camera Configuration Tool Plus (CCT+) or by using binary read/write commands from within your own application to set the camera's control and status registers (CSRs).

Note that when you upload a user shading values file to your camera, you will overwrite any existing values in the camera's user shading values file.

With the CCT+

With the CCT+ (see Section 7.1 on [page 156](#)), you use the Upload button in the Shading Files parameters group to upload a user shading values file. When you click the button, the CCT+ will open a window that lets you navigate to your PC and select a file.

By Setting CSRs

You can upload a user shading values files by writing values to the shading values bulk data CSR. Section 7.2.3 on [page 188](#) explains the bulk data CSRs and Section 7.2.3.3 on [page 191](#) explains how to use the CSRs to upload a file. Section 7.3.1 on [page 197](#) explains using read/write commands.



Note

The factory shading values file can be downloaded from the camera to the PC. The factory shading values file can't be uploaded from the PC to the camera because the factory shading values file in the camera is protected and can't be overwritten.

6.4 Test Images

The test image mode is used to check the camera's basic functionality and its ability to transmit an image via the video data cables. Test images are especially useful for service purposes and for failure diagnostics. In test mode, the image is generated with a software program and the camera's digital devices and does not use the optics, imaging sensor, or ADCs. Four test images are available.

Guidelines When Using Test Images

- When using a test image, take the following guidelines into account:
 - If the camera is set for an exposure mode that uses an ExSync signal, the ExSync signal must be present and must toggle in order to output a line on the test image. Multiple transitions of the ExSync signal will produce a two dimensional image as shown in Figure 44 on [page 133](#) or Figure 46 on [page 134](#).
 - If the camera is set for free run, each cycle of the camera's internal control signal will trigger the output of a line on the test image.
 - The length of the exposure time has no effect on test images.

Enabling Test Images

You can enable a test image with the Camera Configuration Tool Plus (CCT+) or by using binary write commands from within your own application to set the camera's control and status registers (CSRs).

With the CCT+

With the CCT+ (see Section 7.1 on [page 156](#)), you use the Test Image Mode parameter in the Output Mode parameters group to enable a test image.

By Setting CSRs

You enable a test image by writing the appropriate value to the Mode field of the Test Image Mode CSR (see [page 179](#)).

See Section 7.2.2 on [page 164](#) for an explanation of CSRs and Section 7.3.1 on [page 197](#) for an explanation of using read/write commands.

6.4.1 Test Image One (Fixed Gradient)

When the camera is set for an 8 bit output mode, test image one is formed with an odd/even gray scale gradient that ranges from 0 to 255 and repeats every 512 pixels as shown in Figure 43. The odd pixel gradient starts at 0 and steps up, that is, the gray value of pixel 1 is 0, the gray value of pixel 3 is 1, the gray value of pixel 5 is 2, and so forth. The even gradient starts at 255 and steps down, that is, the gray value of pixel 2 is 255, the gray value of pixel 4 is 254, the gray value of pixel 6 is 253, and so forth.

At pixels 256 and 257, the gray value for both pixels is 128. At pixels 511 and 512, a white odd pixel is next to a black even pixel. At pixels 513 and 514, a black odd pixel is next to a white even pixel. To the human eye, the gradient appears to be a varying gray field with a white vertical line every 512 pixels.

Test image one is useful for checking the integrity of the data transmitted by the camera. If you capture lines and examine the pixel values in the captured lines, the values should be exactly as described above.

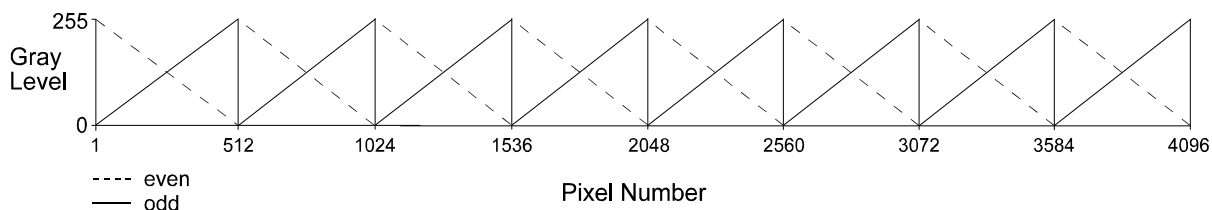

Fig. 43: Formation of Test Image One on a Camera with 4096 Pixels Per Line



Fig. 44: Test Image One



Note

When the camera is set for an 8 bit output mode, the pixel values in test image one range from 0 to 255 as described above.

If the camera is set for 10 bit output, the pixel values will range from 0 to 1023.

If the camera is set for 12 bit output, the pixel values will range from 0 to 4095.

6.4.2 Test Image Two (Moving Gradient)

Test image two is formed with a gray scale gradient that ranges from 0 to 255 and repeats every 256 pixels as shown in Figure 45. The gradient starts at 0 and steps up, that is, the gray value of pixel 1 is 0, the gray value of pixel 2 is 1, the gray value of pixel 3 is 2, and so forth.

The pattern shifts by one pixel each time the ExSync signal or the camera's internal control signal cycles. On the second cycle, the gray value of pixel 1 is 1, the gray value of pixel 2 is 2, the gray value of pixel 3 is 3, and so on. On the third cycle, the gray value of pixel 1 is 2, the gray value of pixel 2 is 3, the gray value of pixel 3 is 4, and so on. This shifting of the gradient makes the pattern appear to be moving as the ExSync signal or the internal control signal cycles.

When you view the output of a camera that is set for test image two, the pattern should appear to be gradually moving up the screen. This feature is useful for determining if the camera is receiving an ExSync signal from your frame grabber and if the frame grabber is receiving every line that is output from your camera.

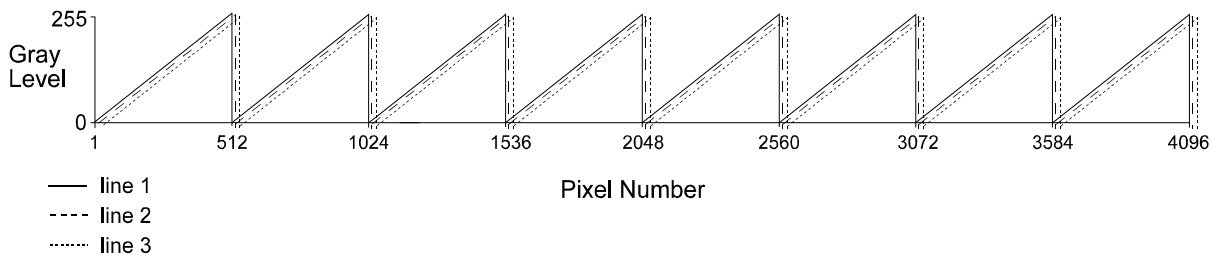

Fig. 45: Formation of Test Image Two on a Camera with 4096 Pixels Per Line



Fig. 46: Test Image Two



Note

When the camera is set for an 8 bit output mode, the pixel values in test image one range from 0 to 255 as described above.

If the camera is set for 10 bit output, the pixel values will range from 0 to 1023.

If the camera is set for 12 bit output, the pixel values will range from 0 to 4095.

6.4.3 Test Image Three (Uniform Black)

In test image three, all pixels will always have a value of 0 regardless of the output mode.

Test image three should always appear as a uniform, black image.

Test image three is useful for checking the integrity of the data transmitted by the camera. If you capture lines and examine the pixel values in the captured lines, the values should be exactly as described above.

6.4.4 Test Image Four (Uniform Gray)

In test image four, all pixels will have a value of 127 when the camera is set for an 8 bit output mode. When the camera is set a 10 bit output mode, all pixels will have a value of 511. And when the camera is set for a 12 bit output mode, all pixels will have a value of 2047.

Test image four should appear as a uniform, gray image.

Test image four is useful for checking the integrity of the data transmitted by the camera. If you capture lines and examine the pixel values in the captured lines, the values should be exactly as described above.

6.5 Line Stamp

The line stamp feature provides you with information about each acquired line such as the line counter value, the sum of the pixel values in the line, and the contrast value of the line. When the line stamp feature is enabled, 16 extra "stamp pixel" values are added to the end of each transmitted line as shown in Figure 47. As an example, the figure illustrates stamp pixels when a camera with 4096 pixels per line is set for a 2 tap video data output mode and edge or level controlled exposure.

Each stamp pixel carries an 8, 10, or 12 bit value that conveys information about the transmitted line.

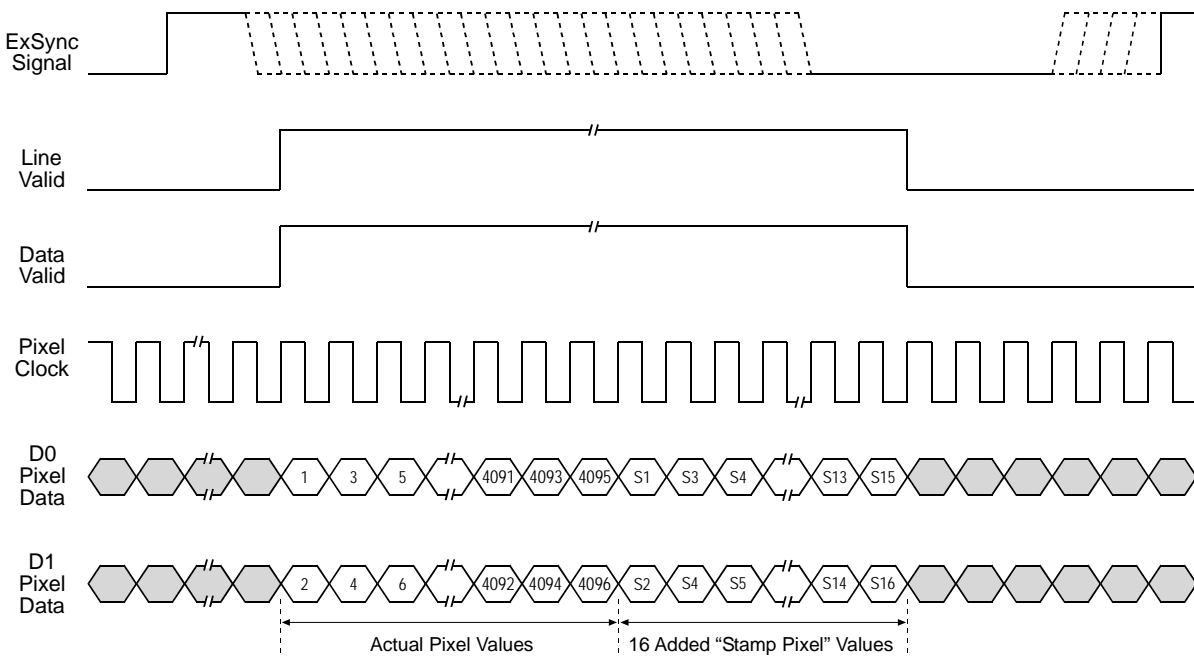

Fig. 47: Stamp Pixels with 2 Tap Video Data Output and Edge or Level Controlled Exposure



Note

When the camera is operating in an 8 bit output mode, the stamp pixels will be 8 bit values.

When the camera is operating in a 10 bit output mode, the stamp pixels will be 10 bit values but only the 8 MSBs will carry information. The 2 LSBs will be packed with zeros.

When the camera is operating in a 12 bit output mode, the stamp pixels will be 12 bit values but only the 8 MSBs will carry information. The 4 LSBs will be packed with zeros.

If the line stamp feature is used together with the AOI feature (see Section 6.2 on [page 118](#)), the stamp pixels are transmitted immediately after the last pixel in the AOI as shown in Figure 48. The figure illustrates what you would see if the AOI was set for a starting pixel of 33 and a length in pixels of 256. The line valid and data valid signals will be high while the pixels in the AOI and the stamp pixels are transmitted.

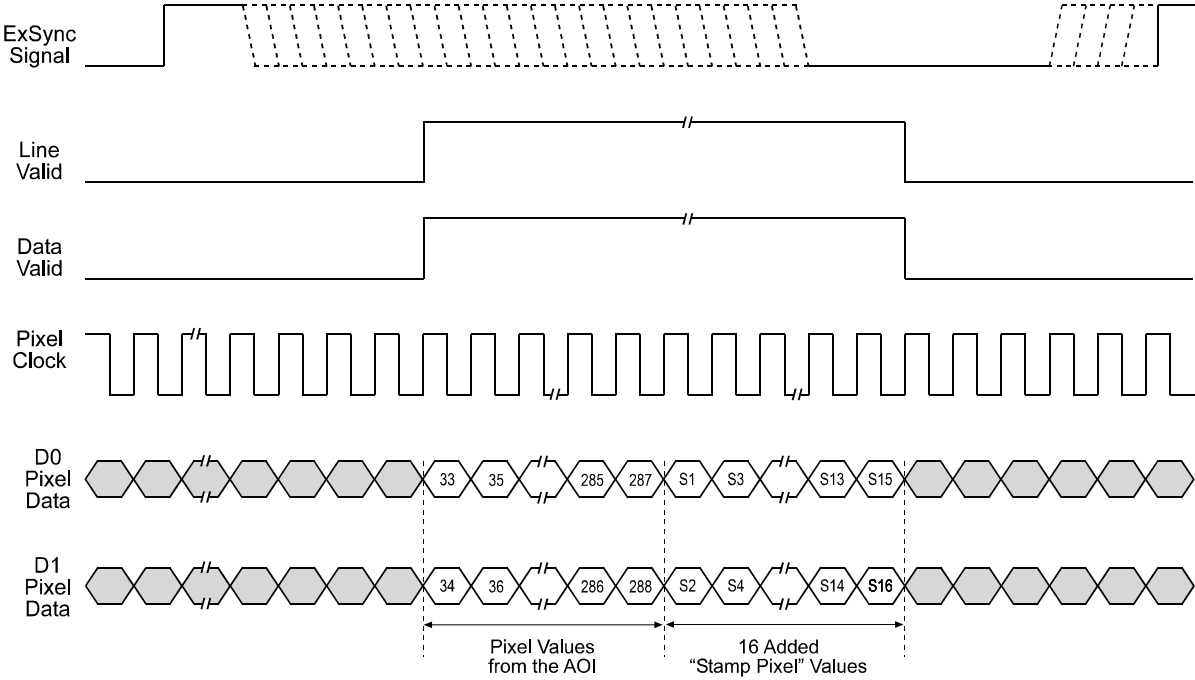

Fig. 48: Stamp Pixels with 2 Tap Video Data Output, Edge or Level Controlled Exposure, and an AOI

The table below lists the function of each stamp pixel. A more detailed explanation of how to interpret the pixel values follows the table.

Position	Function
S1	A fixed value of 0xAA
S2	A fixed value of 0x55 (with camera set for dual line acquisition mode and pixels from line A) A fixed value of 0x57 (with camera set for dual line acquisition mode and pixels from line B) A fixed value of 0x55 (with camera set for any other acquisition mode)
S3	Line Counter (LSByte)
S4	Line Counter (MSByte)
S5	Line Sum (LSByte)
S6	Line Sum (MidByte)
S7	Line Sum (MSByte)
S8	Reserved
S9	Total High Pixels (LSByte)
S10	Total High Pixels (MSByte)
S11	Total Low Pixels (LSByte)
S12	Total Low Pixels (MSByte)
S13	Contrast Value (LSByte)
S14	Contrast Value (MidByte)
S15	Contrast Value (MSByte)
S16	Reserved

Table 28: Stamp Pixel Functions

Stamp Pixels S1 and S2

Stamp pixel S1 always has a fixed value of 0xAA.

If the camera is set for one of the dual line acquisition modes and if the pixel values are from line A, stamp pixel S2 will have a fixed value of 0x55.

If the camera is set for one of the dual line acquisition modes and if the pixel values are from line B, stamp pixel S2 will have a fixed value of 0x57.

If the camera is set for any other line acquisition mode, stamp pixel S2 will have a fixed value of 0x55.

S1 and S2 can be used as a data integrity check. They can also be used to find the start of the stamp pixels.

For more information about line acquisition modes, see Section 3 on [page 39](#).

Stamp Pixels S3 and S4

Stamp pixels S3 and S4 represent the least significant and most significant bytes (respectively) of the line counter. The line counter increments by one for each line captured by the camera. The counter starts at 0 and wraps at 65535 (decimal). The line counter is reset to 0 whenever the camera is switched off or reset. The counter is also reset to 0 whenever the line stamp feature is disabled.

Stamp Pixels S5, S6 and S7

Stamp pixels S5, S6, and S7 represent the least significant, middle and most significant bytes (respectively) of the line sum. The line sum is simply the total of all of the pixel values in the captured line.

The line sum does not include the 16 added “stamp pixels.” If the AOI feature is being used, the line sum is based only on the pixels within the AOI.

Stamp Pixel S8

Stamp pixel S8 is reserved for future use. Currently, its value will always be 0.

Stamp Pixels S9 and S10

Stamp pixels S9 and S10 represent the least significant and most significant bytes (respectively) of the Total High Pixels. The Total High Pixels indicates the number of pixels in the captured line that are above a camera parameter called the “High Pixel Threshold” (see Section 6.5.1 on [page 140](#) for information on setting this parameter).

As an example, assume that the High Pixel Threshold is set to 200. Also assume that the camera has captured a line and that 56 of the pixels in that line have a value greater than 200. In this case, the Total High Pixels in the line would be 56.

The total high pixels does not include any of the 16 added “stamp pixels.” If the AOI feature is being used, the total high pixels is based only on the pixels within the AOI.

Stamp Pixels S11 and S12

Stamp pixels S11 and S12 represent the least significant and most significant bytes (respectively) of the Total Low Pixels. The Total Low Pixels indicates the number of pixels in the captured line that are below a camera parameter called the “Low Pixel Limit” (see Section 6.5.1 on [page 140](#) for information on setting this parameter).

As an example, assume that the Low Pixel Limit is set to 100. Also assume that the camera has captured a line and that 22 of the pixels in that line have a value less than 100. In this case, the Total Low Pixels in the line would be 22.

The total low pixels does not include any of the 16 added “stamp pixels.” If the AOI feature is being used, the total low pixels is based only on the pixels within the AOI.

The total high pixel and total low pixel values are useful if you want to perform automatic gain control from within your camera control software application. If you find that the total low pixel values are increasing over a period of time, an increase in the gain setting would be appropriate. If you find

that the total high pixel values are increasing over a period of time, a decrease in the gain setting would be appropriate.

Stamp Pixels S13, S14, and S15

Stamp pixels S13, S14, and S15 represent the least significant, middle, and most significant bytes (respectively) of the line contrast. The line contrast is the sum of the difference in pixel values for each pair of neighboring pixels in the captured line. In mathematical terms, the line contrast is:

$$\text{Line Contrast} = \sum_{i = \text{first pixel in AOI}}^{\text{last pixel in AOI} - 1} | \text{Pixel Value}_{i+1} - \text{Pixel Value}_i |$$

The line contrast does not include any of the 16 added “stamp pixels.” The line contrast is based only on the pixels within the current AOI (see Section 6.2.1 on [page 120](#)).

Line contrast values are useful when you are adjusting the camera’s focus. Generally, the higher the line contrast value, the better the focus.

Stamp Pixel S16

Stamp pixel S16 is reserved for future use. Currently, its value will always be 0.

6.5.1 Enabling and Setting the Line Stamp

You can enable and set the stamp feature with the Camera Configuration Tool Plus (CCT+) or by using binary write commands from within your own application to set the camera’s control and status registers (CSRs).

With the CCT+

With the CCT+ (see Section 7.1 on [page 156](#)), you use the Stamp Mode parameter in the Stamp parameters group to enable the stamp. You use the Stamp Low Pixel Limit parameter and the Stamp High Pixel Threshold parameter to set the low pixel limit and the high pixel threshold.

By Setting CSRs

You enable the stamp feature by writing the appropriate value to the Mode field of the Line Stamp Mode CSR (see [page 180](#)).

You set the low pixel limit by writing a value to the Low Pixel Limit field in the Line Stamp Low Pixel Limit CSR (see [page 181](#)).

You set the high pixel threshold by writing a value to the High Pixel Threshold field in the Line Stamp High Pixel Threshold CSR (see [page 182](#)).

See Section 7.2.2 on [page 164](#) for an explanation of CSRs and Section 7.3.1 on [page 197](#) for an explanation of using read/write commands.

6.6 Lookup Table

The sensor circuitry in the camera acquires pixel data at 12 bit depth. However, when the camera is set for an 8 bit video data output format, pixel data is only output at 8 bit depth. With the camera set for an 8 bit format, it normally converts the 12 bit data output from the sensor to 8 bit data by simply truncating the least significant 4 bits.

The lookup table feature lets you create a customized table that can be used to map the 12 bit values output from the sensor to 8 bit values that will be transmitted from the camera. Once you have entered values into the lookup table, you can use the table to control 12 bit to 8 bit conversion rather than relying on simple truncation.



Note

When the camera is operating in an 10 bit or 12 bit output mode and when the lookup table feature is enabled, only the 8 MSBs of the transmitted data will carry information. The 2 or 4 LSBs, respectively, will be packed with zeros.

The lookup table has 1025 indexed locations with an 8 bit value stored at each index like this:

Index	Data
0	User defined 8 bit value
4	User defined 8 bit value
8	User defined 8 bit value
12	User defined 8 bit value
16	User defined 8 bit value
•	
•	
•	
4080	User defined 8 bit value
4084	User defined 8 bit value
4088	User defined 8 bit value
4092	User defined 8 bit value
4096	User defined 8 bit value

Table 29: Lookup Table

When the lookup table feature is enabled, the camera will operate in this manner:

- If the sensor reports that a pixel has a 12 bit value of 0, the 8 bit value stored at index 0 will be transmitted.
- If the sensor reports that a pixel has a 12 bit value of 4, the 8 bit value stored at index 4 will be transmitted.
- If the sensor reports that a pixel has a 12 bit value of 8, the 8 bit value stored at index 8 will be transmitted.
 -
 -
 -
 -
- If the sensor reports that a pixel has a 12 bit value of 4084, the 8 bit value stored at index 4084 will be transmitted.
- If the sensor reports that a pixel has a 12 bit value of 4088, the 8 bit value stored at index 4088 will be transmitted.
- If the sensor reports that a pixel has a 12 bit value of 4092, the 8 bit value stored at index 4092 will be transmitted.
- The value stored at index 4096 is used for interpolation.

As you can see, the table does not include a user defined 8 bit value for every 12 bit value that the sensor can report. If the sensor reports a 12 bit pixel value that does not have a corresponding defined 8 bit value, it does a straight line interpolation between the two nearest defined values. For example, assume that the sensor reported that a certain pixel had a 12 bit value of 9. In this case, the camera would perform an interpolation between the values stored at index 8 and index 12 in the table. The result of the interpolation would then be transmitted out of the camera as an 8 bit value.

The value stored at index 4096 is only used for interpolation purposes when the sensor reports a 12 bit pixel value of 4093, 4094, or 4095.

Entering Values Into the Lookup Table

You can enter 8 bit values into the lookup table with the Camera Configuration Tool Plus (CCT+) or by using binary write commands from within your own application to set the camera's control and status registers (CSRs).

With the CCT+

With the CCT+ (see Section 7.1 on [page 156](#)), entering an 8 bit value at an index in the lookup table is a two step process:

1. Use the Lookup Table Index parameter in the Lookup Table parameters group to select an index in the lookup table.
2. Enter a value into the Lookup Table Value parameter in the Lookup Table parameters group. The value will be written to the index you selected in step one.

Repeat steps one and two to enter values for each index in the table.

By Setting CSRs

Entering an 8 bit value at an index in the lookup table is a two step process:

1. Select an index in the lookup table by writing a value to the Index field of the Lookup Table Index CSR (see [page 184](#)).
2. Write an 8 bit value to the Value field of the Lookup Table Value CSR (see [page 185](#)). The 8 bit value will be written to the lookup table index you selected in step one.

Repeat steps one and two to enter values for each index in the table.

See Section 7.2.2 on [page 164](#) for an explanation of CSRs and Section 7.3.1 on [page 197](#) for an explanation of using read/write commands.

Enabling the Lookup Table Feature

You can enable the lookup table feature with the Camera Configuration Tool Plus (CCT+) or by using binary write commands from within your own application to set the camera's control and status registers (CSRs).

With the CCT+

With the CCT+ (see Section 7.1 on [page 156](#)), you use the Lookup Table Enable parameter in the Lookup Table parameters group to enable the lookup table feature.

By Setting CSRs

You enable the lookup table feature by writing the appropriate value to the Mode field of the Lookup Table Mode CSR (see [page 183](#)).

See Section 7.2.2 on [page 164](#) for an explanation of CSRs and Section 7.3.1 on [page 197](#) for an explanation of using read/write commands.

6.7 Imaging Sensor Temperature

The camera is equipped with a temperature sensor that lets you monitor the temperature of the imaging sensor. You can check the temperature of the imaging sensor with the Camera Configuration Tool Plus (CCT+) or by using binary read commands from within your own application to read the camera's inquiry registers.

With the CCT+

With the CCT+ (see Section 7.1 on [page 156](#)), you use the Sensor Temperature parameter in the Camera Information parameters group to check the temperature of the imaging sensor.

By Reading Inquiry Registers

You check the temperature of the imaging sensor by reading the Temperature field of the Imaging Sensor Temperature Inquiry Register (see [page 163](#)).

See Section 7.2.2 on [page 164](#) for an explanation of Inquiry Registers and Section 7.3.1 on [page 197](#) for an explanation of using read/write commands.



Note

If the temperature of the imaging sensor rises above 75° C, an overtemperature error will be declared. See Section 6.9.1 on [page 146](#) for more information about overtemperature error detection.

6.8 Camera Power Undervoltage and Overvoltage Protection

The camera's nominal camera power voltage is 12 VDC ($\pm 10\%$). We do not recommend applying less than 10.8 VDC or greater than 13.2 VDC.

The camera has camera power undervoltage protection:

- If the camera power voltage is less than 10.5 VDC, the camera's internal power regulator will automatically disconnect, and the camera will no longer operate.
- When the camera power voltage is returned to the normal range, the camera will return to normal operation.

The camera also has camera power overvoltage protection up to 25 VDC:

- If the camera power voltage is between 14 and 18 VDC, a camera power overvoltage error will be detected (see Section 6.9.2 on [page 147](#)). The LED on the back of the camera will begin to flash red.
- If ac camera power voltage between 18 and 25 VDC is applied to the camera, the camera's internal power regulator will automatically disconnect, and the camera will no longer operate.
- When the camera power voltage is returned to the normal range, the camera will return to normal operation.

Applying a camera power voltage greater than 25 VDC can seriously damage the camera.

6.9 Error Condition Detection

6.9.1 Imaging Sensor Overtemperature Condition Detected

As described in Section 6.7 on [page 144](#), the camera includes a temperature sensor that is used to monitor the temperature of the imaging sensor.

The camera also has imaging sensor overtemperature protection. If the temperature of the camera's imaging sensor rises above 75° C, an overtemperature condition will be detected and the circuitry for the imaging sensor will switch off. In this situation, you will still be able to communicate with the camera and the camera will still be able to transmit test images, however, no live images can be generated. The imaging sensor circuitry will remain off until its temperature falls below 60° C. Once the sensor temperature falls below 60° C, the error condition will clear and the camera will begin to operate normally.

You can check to see if the camera has detected an overtemperature condition with the Camera Configuration Tool Plus (CCT+) or by using binary read commands from within your own application to read the camera's inquiry registers.

With the CCT+

With the CCT+ (see Section 7.1 on [page 156](#)), you use the Overtemperature parameter in the Camera Information parameters group to determine if an overtemperature condition has been detected. If the value is 1, an overtemperature condition is present.

By Reading Inquiry Registers

You check for an overtemperature condition by reading the value of bit 20 in the Camera Status field of the Camera Status Inquiry Register (see [page 161](#)). If the bit is set to 1, an overtemperature condition is present.

See Section 7.2.1 on [page 158](#) for an explanation of Inquiry Registers and Section 7.3.1 on [page 197](#) for an explanation of using read/write commands.



Note

The Overtemperature parameter in the CCT+ and bit 20 in the Camera Status field of the Camera Status Inquiry Register will be set to 1 when the camera detects an overtemperature condition. They will remain set to 1 until the condition is corrected and a reset or a power off/on is performed.

6.9.2 Camera Power Overvoltage Condition Detected

The required camera power voltage for the camera is 12 VDC \pm 10%.

If a camera power voltage between 14 and 18 VDC is applied to the camera, a camera power overvoltage condition will be detected. The LED on the back of the camera will begin to flash red. When the camera power voltage is returned to its normal range, the error condition will clear and the LED will stop flashing.

(Note that if the camera power voltage rises above 18 VDC, the camera's internal power will switch off as described in Section 6.8 on [page 145](#).)

You can check to see if the camera has detected a camera power overvoltage condition with the Camera Configuration Tool Plus (CCT+) or by using binary read commands from within your own application to read the camera's inquiry registers.

With the CCT+

With the CCT+ (see Section 7.1 on [page 156](#)), you use the Voltage Error parameter in the Camera Information parameters group to determine if a camera power overvoltage condition has been detected. If the value is 1, a camera power overvoltage condition is present.

By Reading Inquiry Registers

You check for an overvoltage condition by reading the value of bit 6 in the Camera Status field of the Camera Status Inquiry Register (see [page 161](#)). If the bit is set to 1, a camera power overvoltage condition is present.

See Section 7.2.1 on [page 158](#) for an explanation of Inquiry Registers and Section 7.3.1 on [page 197](#) for an explanation of using read/write commands.



Note

The Voltage Error parameter in the CCT+ and bit 6 in the Camera Status field of the Camera Status Inquiry Register will be set to 1 when the camera detects a camera power overvoltage condition. They will remain set to 1 until the condition is corrected, i.e., the camera power voltage is returned to its normal range.

Applying a camera power voltage greater than 25 VDC may seriously damage the camera. See Section 6.8 on [page 145](#) for more information.

6.10 Camera Status Checks

During operation, the camera performs a continuous series of self checks. You can view the current camera status in several ways:

- by using the Camera Configuration Tool Plus (see Section 7.1 on [page 156](#)). Check the Camera Status parameter in the Camera Information parameters group to see if any error codes are present.
- by using binary read/write commands from within your own application to read the value in the Camera Status field of the Camera Status inquiry register (see [page 161](#)).
Section 7.2.1 on [page 158](#) explains inquiry registers and Section 7.3.1 on [page 197](#) explains using read/write commands.
- by checking the LED on the back of the camera. If certain error conditions are present, the LED will flash (see Section 8.3 on [page 206](#)).

6.11 Camera Reset

You can initiate a camera reset with the Camera Configuration Tool Plus (CCT+) or by using binary write commands from within your own application to set the camera's control and status registers (CSRs). A reset is the equivalent of switching off power to the camera and switching power back on.

With the CCT+

With the CCT+ (see Section 7.1 on [page 156](#)), click on "Camera" in the menu at the top of the CCT+ window and a drop down list will appear. Click on "Reset Camera" in the drop down list to initiate a reset.

By Setting CSRs

You can initiate a reset by writing the appropriate value to the Reset field of the Camera Reset CSR (see [page 186](#)).

See Section 7.2.2 on [page 164](#) for an explanation of CSRs and Section 7.3.1 on [page 197](#) for an explanation of using read/write commands.



Note

Whenever the camera is powered on or when a camera reset is performed, your PC may receive one random character on the serial interface. We recommend clearing the serial input buffers in your PC after a camera power on or reset.

6.12 Configuration Sets

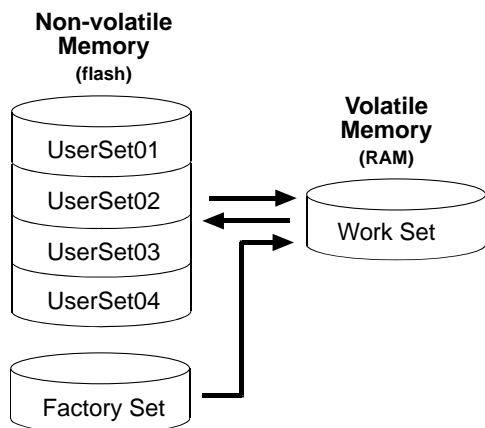

Fig. 49: Configuration Sets

A configuration set is a group of values that contains all of the parameter settings needed to control the camera. There are three basic types of configuration sets: the work configuration set, the factory configuration set, and user configuration sets.

Work Configuration Set

The work configuration set contains the camera's current parameter settings and thus determines the camera's performance. If you use the CCT+ to change the camera settings or if you change settings by writing to the camera's registers, you are making changes to the work configuration set. The work configuration set

resides in the camera's volatile memory and the settings are lost if the camera is reset or if power is switched off. The work configuration set is usually just called the "work set" for short.

Factory Configuration Set

When a camera is manufactured, a test setup is performed on the camera and an optimized configuration is determined. The factory configuration set contains the camera's factory optimized parameter settings. The factory set is saved in a permanent file in the camera's non-volatile memory. The factory set can not be altered by the user and since it is stored in non-volatile memory, it is not lost when the camera is reset or switched off. The factory configuration set is usually just called the "factory set" for short and is named *FactorySet*.

User Configuration Sets

As mentioned above, the work configuration set resides in the camera's volatile memory, and the parameters settings in the work set are lost if the camera is reset or is switched off. The camera can save the parameter settings from the current work set to a file in the camera's non-volatile memory. Files in the non-volatile memory are not lost when the camera is reset or switched off. There are four files in the camera's non-volatile memory available for holding a saved configuration set. A configuration set saved in one of these files is commonly referred to as a "user configuration set" or "user set" for short.

The four files available for holding a saved user configuration set are called, *UserSet01*, *UserSet02*, *UserSet03*, and *UserSet04*.



Note

For 8k cameras, only two user sets (*UserSet01* and *UserSet02*) are available.



Note

The configuration sets described in this section only include parameter settings and the values stored in the lookup table (see Section 6.6 on [page 141](#)).

Configuration sets do not include the values used for shading correction. Values for shading correction are stored in a different file. For more information about shading correction and shading correction values, see Section 6.3 on [page 121](#).

6.12.1 Saving the Work Set to a User Set File

As mentioned above, the work configuration set is stored in the camera's volatile memory and the parameter settings in the work set are lost if the camera is reset or if power is switched off. The camera can save the current work set values in the volatile memory to files in the camera's non-volatile memory. Files in the non-volatile memory are not lost at reset or power off. There are four files available for holding a saved user configuration set: *UserSet01*, *UserSet02*, *UserSet03*, and *UserSet04*. Saved configuration sets are commonly referred to as "user configuration sets" or "user sets."



Note

For 8k cameras, only two user sets (*UserSet01* and *UserSet02*) are available.

Saving a User Configuration Set

You can save the current work set to one of the files in the non-volatile memory by using the Camera Configuration Tool Plus (CCT+) or by using binary read/write commands from within your own application to set the camera's control and status registers (CSRs).

With the CCT+

With the CCT+ (see Section 7.1 on [page 156](#)), you use the File Name Select parameter and the Copy button in the User Set Files parameters group. Clicking the copy button will copy the work set settings to the selected user set file in the non-volatile memory.

By Setting CSRs

You can save the current work set settings to a file in the non-volatile memory by writing values to the bulk data CSR for configuration sets.

Section 7.2.3 on [page 188](#) explains the bulk data CSRs and explains how to use the CSRs to save the work set to a user set file. Section 7.3.1 on [page 197](#) explains using read/write commands.

6.12.2 “Activating” a User Set File or the Factory Set File

As explained on [page 149](#), a factory configuration set containing an optimized set of parameters is created when the camera is manufactured. The factory set is saved in a permanent file in the camera’s non-volatile memory.

As explained on [page 151](#), you can also save up to four different "user" configuration sets to files in the camera’s non-volatile memory.

Assuming that you have saved one or more user set files, you can choose to make one of the saved user set files or the factory set file the “activated” file. When you activate a file, two things happen:

- The values from the activated file are immediately copied into the work set in the camera’s volatile memory. The camera will now actively use the configuration values that were copied into the work set.
- A link is created between the activated file and the camera’s volatile memory. The values in the activated file will automatically be copied into the work set whenever the camera is powered up or reset. (Assume, for example, that the UserSet01 file is the activated file. In this case, when the camera is powered on or reset, the values from the UserSet01 file will be copied into the volatile memory of the camera and will be the actively used parameter settings.)

You can activate a saved user set file or the factory set file by using the Camera Configuration Tool Plus (CCT+) or by using binary read/write commands from within your own application to set the camera’s bulk data control and status registers (CSRs).

With the CCT+

With the CCT+ (see Section 7.1 on [page 156](#)), you use the File Name Select parameter and the Activate button in the User Set Files parameters group to activate a saved user set file or the factory set file.

By Setting CSRs

You can activate a saved user set file or the factory set file by writing values to the bulk data CSR for configuration sets. The bulk data “activate” process is used to activate a stored file.

Section 7.2.3 on [page 188](#) explains bulk data CSRs and using the bulk data activate process. Section 7.3.1 on [page 197](#) explains using read/write commands.

6.12.3 Which Configuration Set File will Load at Startup or at Reset?

On the initial wake-up after delivery, the camera loads the factory configuration set into the work set.

At each subsequent power on or reset, the configuration set file that was last activated is loaded into the work set.

If there is no activated file, the factory set file will be loaded into the work set.

6.12.4 Downloading Configuration Set Files to Your PC

Once you have saved user sets to the user set files in your camera, you can download the user set files to your PC. You can also download the factory set file to your PC.

Using the download function together with the upload function that is described on the next page is useful if you want to transfer a user set file from one camera to another camera of the same type.

You can download a user set file or the factory set file by using the Camera Configuration Tool Plus (CCT+) or by using binary read/write commands from within your own application to set the camera's control and status registers (CSRs).

With the CCT+

With the CCT+ (see Section 7.1 on [page 156](#)), you use the File Name Select parameter in the Configuration Set Files parameters group to select a user set file or the factory set file and use the Download button to download the selected file.

By Setting CSRs

You can download a user set file or the factory set file by writing values to the configuration set bulk data CSR. Section 7.2.3 on [page 188](#) explains the bulk data CSRs and Section 7.2.3.3 on [page 191](#) explains how to use the CSRs to download a file. Section 7.3.1 on [page 197](#) explains using read/write commands.

6.12.5 Uploading Configuration Set Files to Your Camera

Once you have downloaded user configuration set files to your PC as described on the previous page, you can upload the files from your PC to a camera.

Using the download function together with the upload function is useful if you want to transfer a user set file from one camera to another camera of the same type.

You can upload a user set file by using the Camera Configuration Tool Plus (CCT+) or by using binary read/write commands from within your own application to set the camera's control and status registers (CSRs).

Note that when you upload a user set file to your camera, you will overwrite any existing values in the camera's user set file of the same name.

With the CCT+

With the CCT+ (see Section 7.1 on [page 156](#)), you use the Upload button in the Configuration Set Files parameters group to upload a user set file. When you click the button, the CCT+ will open a window that lets you navigate to your PC and select a file.

By Setting CSRs

You can upload a user set file by writing values to the configuration set bulk data CSR. Section 7.2.3 on [page 188](#) explains the bulk data CSRs and Section 7.2.3.3 on [page 191](#) explains how to use the CSRs to upload a file. Section 7.3.1 on [page 197](#) explains using read/write commands.



Note

The factory configuration set file can be downloaded from the camera to the PC. The factory configuration set file can't be uploaded from the PC to the camera because the factory configuration set file in the camera is protected and can't be overwritten.

7 Configuring the Camera

The camera comes with a factory set of parameters that will work properly for most applications with only minor changes. For normal operation, the following parameters are usually configured by the user:

- Video data output mode
- Line acquisition mode
- Exposure time control mode
- Exposure time (for ExSync programmable or free run programmable exposure modes)
- Line period (for free run exposure modes)

To customize operation for your particular application, the following parameters may also need to be configured:

- Gain
- Offset
- Area of interest
- Stamp
- Shading correction

The camera is programmable via the RS-644 serial connection that is integrated into the Camera Link interface between the frame grabber and the camera. Two methods can be used to change the camera's parameters:

- The first and easier approach is to change the parameters using the Camera Configuration Tool Plus (CCT+). The CCT+ is especially useful during initial camera testing and the camera design in process. See Section 7.1 on [page 156](#) for more information about the configuration tool.
- You can also change the parameters directly from within your application software by using binary read/write commands to set values in the camera's registers (see Section 7.2 on [page 157](#)).

7.1 Configuring the Camera with the Camera Configuration Tool Plus (CCT+)

The Camera Configuration Tool Plus (CCT+) is a Windows™ based program used to easily change the camera's parameter settings. The CCT+ is especially useful during initial camera testing and the camera design in process.

The CCT+ communicates via the RS-644 serial connection that is integrated into the Camera Link interface between the frame grabber and the camera. The tool automatically generates the binary programming commands that are described in Section 7.2 on [page 157](#).

The Installation and Setup Guide for Camera Link Cameras includes detailed information about installing the CCT+ and includes instructions that describe how to use the CCT+ to change the camera's parameters. The guide is available in the downloads section of the Basler website: www.baslerweb.com.



Note

In demo mode, the CCT+ does not cover the full functionality of the camera. We therefore recommend not to use the CCT+ in demo mode.

7.2 Configuring the Camera By Setting Registers

The camera has blocks of mapped memory space known as registers. By reading values from the registers, you can determine basic information about the camera and information about the camera's current parameter settings. By writing values to the registers, you can set camera parameters and control how the camera's features will operate. There are three types of registers in the camera:

Inquiry Registers - these registers provide basic information about the camera. Section 7.2.1 on [page 158](#) explains inquiry registers in more detail, lists the inquiry registers in the camera, and describes the function of each register.

Feature Control and Status Registers - these registers let you set the parameters associated with the camera's features. Section 7.2.2 on [page 164](#) explains feature control and status registers in more detail, lists the feature control and status registers in the camera, and describes the function of each register.

Bulk Data Control and Status Registers - these registers let you store and recall sets of values that the camera uses as a group. Section 7.2.3 on [page 188](#) explains bulk data and the bulk data control and status registers in more detail. It also lists the bulk data registers in the camera and describes the function of each register.

A special binary read/write command protocol is used to read from and write to the registers in the camera. Read and write commands are sent to the camera via the RS-644 serial link between the camera and the frame grabber. Section 7.3.1 on [page 197](#) describes the binary read/write command protocol in detail and also provides information on using the serial link. Sample code that illustrates how to use the read/write commands is available from Basler (see Section 7.4 on [page 204](#)).

7.2.1 Inquiry Registers

Inquiry registers contain basic information about the camera and information about the camera's current status. Each inquiry register contains one or more fields and each field has an assigned address within the camera's memory space. By using a binary read command, you can read the data in a field and get information about the camera.

The address for any field within a register is equal to the register base address plus the offset for the field. For example, the Vendor Information Inquiry Register (see below) has a Vendor Name field with an address of 0x0101 (the base address of 0x0100 plus an offset of 0x0001). By reading the data at address 0x0101, you can get information about the camera vendor's name.

The section starting below lists the inquiry registers in the camera and shows detailed information about the use of each field within the registers.

7.2.1.1 Inquiry Register Details

Vendor Information Inquiry

Register Base Address: 0x0100			
Field Name: Register Status	Offset: 0x0000	Size: 1 Byte	Type: Read only
Description: The integer value in this field indicates the status of this inquiry register: 0x00 = The register is not available 0x01 = The register is available			
Field Name: Vendor Name	Offset: 0x0001	Size: 20 Bytes	Type: Read only
Description: String containing the camera vendor's name. The string is zero terminated if less than 20 bytes are needed and unterminated if all 20 bytes are needed.			

Model Information Inquiry

Register Base Address: 0x0200			
Field Name: Register Status	Offset: 0x0000	Size: 1 Byte	Type: Read only
Description: The integer value in this field indicates the status of this inquiry register: 0x00 = The register is not available 0x01 = The register is available			
Field Name: Model Info	Offset: 0x0001	Size: 20 Bytes	Type: Read only
Description: String containing the camera's model number. The string is zero terminated if less than 20 bytes are needed and unterminated if all 20 bytes are needed.			

Product ID Inquiry

Register Base Address: 0x0300			
Field Name: Register Status	Offset: 0x0000	Size: 1 Byte	Type: Read only
Description: The integer value in this field indicates the status of this inquiry register: 0x00 = The register is not available 0x01 = The register is available			
Field Name: Product ID	Offset: 0x0001	Size: 20 Bytes	Type: Read only
Description: String containing the camera's product ID number. The string is zero terminated if less than 20 bytes are needed and unterminated if all 20 bytes are needed.			

Serial Number Inquiry

Register Base Address: 0x0400			
Field Name: Register Status	Offset: 0x0000	Size: 1 Byte	Type: Read only
Description: The integer value in this field indicates the status of this inquiry register: 0x00 = The register is not available 0x01 = The register is available			
Field Name: Serial Number	Offset: 0x0001	Size: 20 Bytes	Type: Read only
Description: String containing the camera's serial number. The string is zero terminated if less than 20 bytes are needed and unterminated if all 20 bytes are needed.			

Camera Version Inquiry

Register Base Address: 0x0500			
Field Name: Register Status	Offset: 0x0000	Size: 1 Byte	Type: Read only
Description: The integer value in this field indicates the status of this inquiry register: 0x00 = The register is not available 0x01 = The register is available			
Field Name: Camera Version	Offset: 0x0001	Size: 3 Bytes	Type: Read only
Description: The value in this field indicates the camera's version information. The bytes in the field are interpreted as follows: Byte 1 = Low byte of the camera version (BCD coded) Byte 2 = High byte of the camera version (BCD coded) Byte 3 = Register layout ID (BCD coded)			

Firmware Version Inquiry

Register Base Address: 0x0510			
Field Name: Register Status	Offset: 0x0000	Size: 1 Byte	Type: Read only
Description: The integer value in this field indicates the status of this inquiry register: 0x00 = The register is not available 0x01 = The register is available			
Field Name: Firmware Version	Offset: 0x0001	Size: 128 Bytes	Type: Read only
Description: String containing the camera's firmware version. The string is zero terminated if less than 128 bytes are needed and unterminated if all 128 bytes are needed.			

Camera Status Inquiry

The camera has been programmed to detect several error conditions. When an error condition is detected, a flag is set. The camera status inquiry register allows you to read the error flags.

Register Base Address: 0x0C00			
Field Name: Register Status	Offset: 0x0000	Size: 1 Byte	Type: Read only
Description: The integer value in this field indicates the status of this inquiry register: 0x00 = The register is not available 0x01 = The register is available			
Field Name: Camera Status	Offset: 0x0001	Size: 4 Bytes	Type: Read only
Description: Each bit in this field specifies an error condition (see table below). Bit 0 is the least significant bit. If a bit is set to 1, the error condition assigned to that bit is present. If the bit is set to 0, the error is not present.			
Bit	Description		
0	Reserved		
1	The camera is busy performing an internal operation (such as generating shading values).		
2	A reset has occurred.		
3	Parameter error. For example, a parameter has been set to a value that is out of range or not allowed. A black image is produced (all pixel values are equal to zero).		
4	A user set load has failed.		
5	A file operation has failed.		
6	A camera power overvoltage condition is present (see Section 6.9.2 on page 147).		
7	A binary read/write command protocol error has been detected. For more information about the error, read the Binary Command Protocol Status Inquiry Register (see page 163). This bit is auto-cleared on read.		
8 ... 15	Reserved		
16	An FPGA not ready error has occurred. For more information about the error, read the FPGA Status Inquiry register (see page 162). This bit clears when you read the FPGA Status Inquiry register.		
17	A trigger error has occurred. Either the maximum allowed line rate has been exceeded or the ExSync signal is missing. For more information about the error, read the FPGA Status Inquiry register (see page 162). This bit clears when you read the FPGA Status inquiry register.		
18	Reserved		
19	The last shading value generation process failed. The DSNU shading value generation process can fail if the pixel values in the lines captured during the generation process are too high. (This process should be performed in darkness or in very low light conditions.) The PRNU shading value generation process can fail if the values for the darkest pixels in the captured lines are less than 1/2 of the values for the highest pixels. This problem is often caused by extremely non-uniform lighting or by poor quality optics. This bit will clear when you perform a successful shading value generation process.		
20	An overtemperature condition is present (see Section 6.9.1 on page 146).		
21 ... 31	Reserved		

FPGA Status Inquiry

The camera has been programmed to detect several error conditions in its field programmable gate array (FPGA). When an error condition is detected, a flag is set. The FPGA status inquiry register allows you to read the error flags.

Register Base Address: 0x0C10			
Field Name: Register Status	Offset: 0x0000	Size: 1 Byte	Type: Read only
Description: The integer value in this field indicates the status of this inquiry register: 0x00 = The register is not available 0x01 = The register is available			
Field Name: FPGA Status	Offset: 0x0001	Size: 1 Byte	Type: Read only
Description: Each bit in this field specifies an error condition (see table below). Bit 0 is the least significant bit. If a bit is set to 1, the error condition assigned to that bit is present. If the bit is set to 0, the error is not present.			
Bit	Description		
0	No FPGA firmware available.		
1	FPGA firmware is available, but the firmware has failed to load.		
2	The camera's maximum line rate has been exceeded. (Note: If you are operating the camera in ExSync programmable mode and you trigger the camera faster than allowed, the camera will automatically ignore any trigger signals that would cause a max line rate exceeded condition and this bit will not be set.)		
3	There is no ExSync signal.		
4	Reserved		
5	Reserved		
6	Reserved		
	Reserved		
7	Reserved		

Binary Command Protocol Status Inquiry

The camera has been programmed to detect several errors in the format of any binary commands received by the camera. When an error condition is detected, a flag is set. The binary command status inquiry register allows you to read the error flags.

Register Base Address: 0x0C30			
Field Name: Register Status	Offset: 0x0000	Size: 1 Byte	Type: Read only
Description: The integer value in this field indicates the status of this inquiry register: 0x00 = The register is not available 0x01 = The register is available			
Field Name: Binary Command Status	Offset: 0x0001	Size: 1 Byte	Type: Read only
Description: Each bit in this field specifies an error condition (see table below). Bit 0 is the least significant bit. If a bit is set to 1, the error condition assigned to that bit is present. If the bit is set to 0, the error is not present.			
Bit	Description		
0	A binary command with no BFS was received (see Section 7.3.1 on page 197).		
1	A byte timeout has occurred (see Section 7.3.1.1 on page 200).		
2	A binary command with an invalid OpCode was received (see Section 7.3.1 on page 197).		
3	A binary command with no BFE was received (see Section 7.3.1 on page 197).		
4	A binary command with an incorrect BCC was received (see Section 7.3.1 on page 197).		
5	A binary command with an address error was received (see Section 7.3.1 on page 197).		
6	Reserved		
7	An unknown error has occurred.		

Imaging Sensor Temperature Inquiry

Register Base Address: 0x2710			
Field Name: Register Status	Offset: 0x0000	Size: 1 Byte	Type: Read only
Description: The integer value in this field indicates the status of this inquiry register: 0x00 = The register is not available 0x01 = The register is available			
Field Name: Temperature	Offset: 0x0001	Size: 4 Bytes	Type: Read only
Description: The value in this field indicates the temperature of the imaging sensor in °C. The value in this field is a standard IEEE-754 single precision (32 bit) floating point number.			

7.2.2 Feature Control and Status Registers

The feature control and status registers (CSRs) let you set the parameters for camera features such as exposure mode, gain, offset, and the AOI. These registers also let you check the current parameter settings and the status for each feature.

Each feature has one or more CSRs associated with it. The fields within a feature's CSR(s) are used to control how the feature operates. By using binary write commands to write to fields within a feature's CSR(s), you can change the parameter settings for the feature. By using binary read commands, you can determine the current setting for the parameters and get information about the feature's status.

The address for any field within a register is equal to the register base address plus the offset for the field. Look at the Video Data Output Mode CSR on [page 173](#) as an example. The Mode field of this register has an address of 0x1701 (the base address of 0x1700 plus the offset of 0x0001). By writing a value to this address, you can set the video data output mode. By reading the value at this address, you can determine the current output mode setting.

The Video Data Output Mode CSR is a simple CSR with only two fields. Most of the other feature CSRs have several read/write fields that let you set the parameters associated with the feature. They may also have read only fields that contain information about the minimum and maximum allowed setting for each parameter. Section 7.2.2.2 on [page 166](#) lists the feature CSRs in the camera and shows detailed information about the use of each field within the register.

7.2.2.1 “Raw” Value Fields vs. “Absolute” Value Fields

As you look through the descriptions of the feature CSRs, you will notice that some CSRs have a parameter that can be set by writing a value to a “raw” field or by writing a value to an “absolute” field. You will find this to be true for the Exposure Time, Line Period, Gain, and Offset parameters. The common characteristic among these parameters is that they are “scalar”, i.e., they can be set to a value within a continuous scale rather than just a small set of individually defined values. Any one of these scalar parameters can be set on a “raw” scale or on an “absolute” scale. A raw scale is simply a range of integer values that has no defined units. An absolute scale is a range of floating point values that has defined units.

Consider the Gain parameter as an example:

Setting the Raw Gain

If you set the gain by writing a value to the Raw Gain field of the Gain CSR, you can write any integer value from 2731 to 16383 (decimal). Writing an integer value to the raw register sets the gain, but it doesn't directly tell you how many dB of gain you will be getting from the camera at that setting. To determine the dB of gain you are getting at a particular raw gain setting, you must use the formula:

$$\text{Gain in dB} = 20 \times \log_{10} \left(\frac{\text{setting}}{4096} \right)$$

Setting the Absolute Gain

If you set the gain by writing a value to the Absolute Gain field of the Gain CSR, you can write a floating point value from -3.5 to +12.04 (decimal) in increments of 0.01. Writing a floating point value to the absolute register sets the gain directly in dB. For example, if the absolute gain field is set to 3.42, then the camera would be set for 3.42 dB of gain.

**Note**

You do not need to set both the raw field and the absolute field. Setting just one of the fields is sufficient and you can choose to set whichever field best suits your needs.

7.2.2.2 Feature Control and Status Register Details

Camera Link Clock Speed CSR

Register Base Address: 0x3900			
Field Name: Register Status	Offset: 0x0000	Size: 1 Byte	Type: Read only
Description: The integer value in this field indicates the status of this control and status register: 0x00 = The register is not available 0x01 = The register is available and all related settings are OK 0x80 = A value in the register is set out of range			
Field Name: Clock Speed	Offset: 0x0001	Size: 1 Byte	Type: Read/Write
Description: Writing an integer to this field sets the clock speed for the Camera Link interface: 0x06 = 40 MHz clock speed 0x0e = 80 MHz clock speed See Section 2.8.4 on page 35 for more information about the Camera Link clock speed.			

Video Data Output Mode CSR

Register Base Address: 0x1700			
Field Name: Register Status	Offset: 0x0000	Size: 1 Byte	Type: Read only
Description: The integer value in this field indicates the status of this control and status register: 0x00 = The register is not available 0x01 = The register is available and all related settings are OK 0x80 = A value in the register is set out of range			
Field Name: Mode	Offset: 0x0001	Size: 1 Byte	Type: Read/Write
Description: Writing an integer to this field sets the video data output mode: 0x01 = 2 Tap 8 Bit Mode 0x03 = 2 Tap 10 Bit Mode 0x05 = 2 Tap 12 Bit Mode 0x10 = 4 Tap 8 Bit Mode 0x11 = 8 Tap 8 Bit Mode 0x12 = 4 Tap 10 Bit Mode 0x13 = 4 Tap 12 Bit Mode See Chapter 5 on page 85 for a description of the video data output modes.			

Line Acquisition Mode CSR

Register Base Address: 0x3600			
Field Name: Register Status	Offset: 0x0000	Size: 1 Byte	Type: Read only
Description: The integer value in this field indicates the status of this control and status register: 0x00 = The register is not available 0x01 = The register is available and all related settings are OK 0x80 = A value in the register is set out of range			
Field Name: Mode	Offset: 0x0001	Size: 1 Byte	Type: Read/Write
Description: Writing an integer to this field sets the line acquisition mode: 0x00 = Single Line [Max 70 kHz] 0x02 = Vertical Binning 0x03 = Time Delayed Line Summing - Line A Delayed 0x04 = Time Delayed Line Summing - Line B Delayed 0x05 = Line Averaging 0x06 = Time Delayed Line Averaging - Line A Delayed 0x07 = Time Delayed Line Averaging - Line B Delayed 0x08 = Dual Line [Max 140 kHz] - Line A First 0x09 = Dual Line [Max 140 kHz] - Line B First See Chapter 3 on page 39 for a description of the line acquisition modes.			

Horizontal Binning CSR

Register Base Address: 0x1B00			
Field Name: Register Status	Offset: 0x0000	Size: 1 Byte	Type: Read only
Description: The integer value in this field indicates the status of this control and status register: 0x00 = The register is not available 0x01 = The register is available and all related settings are OK 0x80 = A value in the register is set out of range			
Field Name: Mode	Offset: 0x0001	Size: 1 Byte	Type: Read/Write
Description: Writing an integer to this field sets the horizontal binning mode: 0x00 = Horizontal binning disabled 0x01 = Horizontal binning enabled See Chapter 3.8 on page 59 for more information about the horizontal binning feature.			

Exposure Time Control Mode CSR

Register Base Address: 0x1400			
Field Name: Register Status	Offset: 0x0000	Size: 1 Byte	Type: Read only
Description: The integer value in this field indicates the status of this control and status register: 0x00 = The register is not available 0x01 = The register is available and all related settings are OK 0x80 = A value in the register is set out of range			
Field Name: Mode	Offset: 0x0001	Size: 1 Byte	Type: Read/Write
Description: Writing an integer to this field sets the exposure time control mode: 0x00 = Free run, programmable 0x02 = Free run, edge controlled 0x04 = ExSync. level controlled 0x05 = ExSync, programmable 0x06 = ExSync, edge controlled See Section 4.1 on page 67 for a description of the exposure time control modes.			

Exposure Time CSR

Note: The exposure time can be set by writing a floating point value to the Absolute Exposure Time field or by writing an integer value to the Raw Exposure Time field. See Section 7.2.2.1 on [page 164](#) for an explanation of the difference between these two fields.

Register Base Address: 0x1500			
Field Name: Register Status	Offset: 0x0000	Size: 1 Byte	Type: Read only
Description: The integer value in this field indicates the status of this control and status register: 0x00 = The register is not available 0x01 = The register is available and all related settings are OK 0x80 = A value in the register is set out of range			
Field Name: Absolute Exposure Time	Offset: 0x0001	Size: 4 Bytes	Type: Read/Write
Description: Writing a floating point value to this field sets the exposure time in μs . For example, if the value in this field is set to 5.2, the exposure time will be 5.2 μs . The allowed range for the exposure time can vary depending on the camera model and how the camera is configured. You should check the absolute min and absolute max fields of this register to determine the allowed range with the current configuration. The increment is 0.1. The value in this field is a standard IEEE-754 single precision (32 bit) floating point number. See Chapter 4 on page 67 for more information about exposure time.			
Field Name: Absolute Min	Offset: 0x0005	Size: 4 Bytes	Type: Read only
Description: Minimum allowed floating point value for the absolute exposure time setting. This field is updated to reflect limitations caused by the way that any related features are set. The value in this field is a standard IEEE-754 single precision (32 bit) floating point number.			
Field Name: Absolute Max	Offset: 0x0009	Size: 4 Bytes	Type: Read only
Description: Maximum allowed floating point value for the absolute exposure time setting. This field is updated to reflect limitations caused by the way that any related features are set. The value in this field is a standard IEEE-754 single precision (32 bit) floating point number.			
Field Name: Raw Exposure Time	Offset: 0x000D	Size: 4 Bytes	Type: Read/Write
Description: Writing an integer value to this field sets the exposure time. The allowed range for this value can vary depending on the camera model and how the camera is configured. You should check the raw min and raw max fields of this register to determine the allowed range with the current configuration. The integer value represents a multiplier, and the actual exposure time is equal to the value in this field times 0.1 μs . For example, if the value in this field is set to 1200, then: Exposure Time = 1200 x 0.1 μs Exposure Time = 120 μs The bytes in this field are interpreted as follows: Byte 1 = Low byte of the raw value Byte 2 = Mid byte of the raw value Byte 3 = High byte of the raw value Byte 4 = Always 0 (not used)			

Field Name: Raw Min	Offset: 0x0011	Size: 4 Bytes	Type: Read only
Description: Minimum allowed integer value for the raw exposure time setting. This field is updated to reflect limitations caused by the way that any related fields are set. The bytes in this field are interpreted as follows: Byte 1 = Low byte of the min value Byte 2 = Mid byte of the min value Byte 3 = High byte of the min value Byte 4 = Always 0 (not used)			
Field Name: Raw Max	Offset: 0x0015	Size: 4 Bytes	Type: Read only
Description: Maximum allowed integer value for the raw exposure time setting. This field is updated to reflect limitations caused by the way that any related fields are set. The bytes in this field are interpreted as follows: Byte 1 = Low byte of the max value Byte 2 = Mid byte of the max value Byte 3 = High byte of the max value Byte 4 = Always 0x00 (not used)			

Line Period CSR

Note: The line period can be set by writing a floating point value to the Absolute Line Period field or by writing an integer value to the Raw Line Period field. See Section 7.2.2.1 on [page 164](#) for an explanation of the difference between these two fields.

Register Base Address: 0x1600			
Field Name: Register Status	Offset: 0x0000	Size: 1 Byte	Type: Read only
Description: The integer value in this field indicates the status of this control and status register: 0x00 = The register is not available 0x01 = The register is available and all related settings are OK 0x80 = A value in the register is set out of range			
Field Name: Absolute Line Period	Offset: 0x0001	Size: 4 Bytes	Type: Read/Write
Description: Writing a floating point value to this field sets the line period in μs . For example, if the value in this field is set to 180.6, the line period will be 180.6 μs . The allowed range for the absolute line period can vary depending on the camera model and how the camera is configured. You should check the absolute min and absolute max fields of this register to determine the allowed range with the current configuration. The increment is 0.1. The value in this field is a standard IEEE-754 single precision (32 bit) floating point number. See Section 4.2 on page 71 for more information about the line period.			
Field Name: Absolute Min	Offset: 0x0005	Size: 4 Bytes	Type: Read only
Description: Minimum allowed floating point value for the absolute line period setting. This field is updated to reflect limitations caused by the way that any related features are set. The value in this field is a standard IEEE-754 single precision (32 bit) floating point number.			
Field Name: Absolute Max	Offset: 0x0009	Size: 4 Bytes	Type: Read only
Description: Maximum allowed floating point value for the absolute line period setting. This field is updated to reflect limitations caused by the way that any related features are set. The value in this field is a standard IEEE-754 single precision (32 bit) floating point number.			
Field Name: Raw Line Period	Offset: 0x000D	Size: 4 Bytes	Type: Read/Write
Description: Writing an integer value to this field sets the line period. The allowed range for this value can vary depending on the camera model and how the camera is configured. You should check the raw min and raw max fields of this register to determine the allowed range with the current configuration. The integer value represents a multiplier, and the line period is equal to the value in this field times 0.1 μs . For example, if the value in this field is set to 1500, then: $\text{Line Period} = 1500 \times 0.1 \mu\text{s}$ $\text{Exposure Time} = 150 \mu\text{s}$ The bytes in this field are interpreted as follows: Byte 1 = Low byte of the raw value Byte 2 = Mid byte of the raw value Byte 3 = High byte of the raw value Byte 4 = Always 0 (not used)			

Field Name: Raw Min	Offset: 0x0011	Size: 4 Bytes	Type: Read only
Description: Minimum allowed integer value for the raw line period setting. This field is updated to reflect limitations caused by the way that any related fields are set. The bytes in this field are interpreted as follows: Byte 1 = Low byte of the min value Byte 2 = Mid byte of the min value Byte 3 = High byte of the min value Byte 4 = Always 0 (not used)			
Field Name: Raw Max	Offset: 0x0015	Size: 4 Bytes	Type: Read only
Description: Maximum allowed integer value for the raw line period setting. This field is updated to reflect limitations caused by the way that any related fields are set. The bytes in this field are interpreted as follows: Byte 1 = Low byte of the max value Byte 2 = Mid byte of the max value Byte 3 = High byte of the max value Byte 4 = Always 0x00 (not used)			

Gain CSR

Note: The gain can be set by writing a floating point value to the Absolute Gain field or by writing an integer value to the Raw Gain field. See Section 7.2.2.1 on [page 164](#) for an explanation of the difference between these two fields.

Register Base Address: 0x0E00			
Field Name: Register Status	Offset: 0x0000	Size: 1 Byte	Type: Read only
Description: The integer value in this field indicates the status of this control and status register: 0x00 = The register is not available 0x01 = The register is available and all related settings are OK 0x80 = A value in the register is set out of range			
Field Name: Absolute Gain	Offset: 0x0001	Size: 4 Bytes	Type: Read/Write
Description: Writing a floating point value to this field sets the gain in dB. The value in this field is a standard IEEE-754 single precision (32 bit) floating point number. See Section 6.1 on page 115 for more information about gain.			
Field Name: Absolute Min	Offset: 0x0005	Size: 4 Bytes	Type: Read only
Description: Minimum allowed floating point value for the absolute gain setting. The value in this field is a standard IEEE-754 single precision (32 bit) floating point number.			
Field Name: Absolute Max	Offset: 0x0009	Size: 4 Bytes	Type: Read only
Description: Maximum allowed floating point value for the absolute gain setting. The value in this field is a standard IEEE-754 single precision (32 bit) floating point number.			
Field Name: Raw Gain	Offset: 0x000D	Size: 2 Bytes	Type: Read/Write
Description: Writing an integer value to this field sets the gain. The dB of gain that the camera will achieve at a given setting is determined by the formula shown in Section 6.1 on page 115 . The bytes in this field are interpreted as follows: Byte 1 = Low byte of the raw value Byte 2 = High byte of the raw value			
Field Name: Raw Min	Offset: 0x000F	Size: 2 Bytes	Type: Read only
Description: Minimum allowed integer value for the raw gain setting. The bytes in this field are interpreted as follows: Byte 1 = Low byte of the min value Byte 2 = High byte of the min value			
Field Name: Raw Max	Offset: 0x0011	Size: 2 Bytes	Type: Read only
Description: Maximum allowed integer value for the raw gain setting. The bytes in this field are interpreted as follows: Byte 1 = Low byte of the max value Byte 2 = High byte of the max value			

Offset CSR

Note: The offset can be set by writing a floating point value to the Absolute Offset field or by writing an integer value to the Raw Offset field. See Section 7.2.2.1 on [page 164](#) for an explanation of the difference between these two fields.

Register Base Address: 0x0F00			
Field Name: Register Status	Offset: 0x0000	Size: 1 Byte	Type: Read only
Description: The integer value in this field indicates the status of this control and status register: 0x00 = The register is not available 0x01 = The register is available and all related settings are OK 0x80 = A value in the register is set out of range			
Field Name: Absolute Offset	Offset: 0x0001	Size: 4 Bytes	Type: Read/Write
Description: Writing a floating point value to this field directly sets the offset in DN (digital numbers). For example, if you set this value to +5.00, you would increase the digital values output from the camera by 5. The allowed range for the absolute offset can vary depending on how the camera is configured. You should check the absolute min and absolute max fields of this register to determine the allowed range with the current configuration. The increment is 0.01. The value in this field is a standard IEEE-754 single precision (32 bit) floating point number. See Section 6.1 on page 115 for more information about offset.			
Field Name: Absolute Min	Offset: 0x0005	Size: 4 Bytes	Type: Read only
Description: Minimum allowed floating point value for the absolute offset setting. The value in this field is a standard IEEE-754 single precision (32 bit) floating point number.			
Field Name: Absolute Max	Offset: 0x0009	Size: 4 Bytes	Type: Read only
Description: Maximum allowed floating point value for the absolute offset setting. The value in this field is a standard IEEE-754 single precision (32 bit) floating point number.			

Field Name: Raw Offset	Offset: 0x000D	Size: 2 Bytes	Type: Read/Write
<p>Description: Writing an integer value to this field sets the offset.</p> <p>The allowed range for this value can vary depending on how the camera is configured. You should check the raw min and raw max fields of this register to determine the allowed range with the current configuration.</p> <p>The DN of offset that the camera will apply is determined as follows:</p> <p>If the camera is set for an 8 bit video data output mode, increasing the integer value by 16 will increase the digital values output from the camera by 1 and decreasing the integer value by 16 will decrease the digital values output from the camera by 1.</p> <p>If the camera is set for a 10 bit video data output mode, increasing the integer value by 4 will increase the digital values output from the camera by 1 and decreasing the integer value by 4 will decrease the digital values output from the camera by 1.</p> <p>If the camera is set for a 12 bit video data output mode, increasing the integer value by 1 will increase the digital values output from the camera by 1 and decreasing the integer value by 1 will decrease the digital values output from the camera by 1.</p> <p>The bytes in this field are interpreted as follows:</p> <p>Byte 1 = Low byte of the raw value</p> <p>Byte 2 = High byte of the raw value</p>			
Field Name: Raw Min	Offset: 0x000F	Size: 2 Bytes	Type: Read only
<p>Description: Minimum allowed integer value for the raw gain setting.</p> <p>The bytes in this field are interpreted as follows:</p> <p>Byte 1 = Low byte of the min value</p> <p>Byte 2 = High byte of the min value</p>			
Field Name: Raw Max	Offset: 0x0011	Size: 2 Bytes	Type: Read only
<p>Description: Maximum allowed integer value for the raw gain setting.</p> <p>The bytes in this field are interpreted as follows:</p> <p>Byte 1 = Low byte of the max value</p> <p>Byte 2 = High byte of the max value</p>			

Area of Interest Starting Pixel CSR

Register Base Address: 0x1000			
Field Name: Register Status	Offset: 0x0000	Size: 1 Byte	Type: Read only
<p>Description: The integer value in this field indicates the status of this control and status register:</p> <p>0x00 = The register is not available</p> <p>0x01 = The register is available and all related settings are OK</p> <p>0x80 = A value in the register is set out of range</p>			
Field Name: Starting Pixel	Offset: 0x0001	Size: 2 Bytes	Type: Read/Write
<p>Description: Writing an integer to this field sets the starting pixel for the area of interest (AOI) feature.</p> <p>The area of interest starting pixel can be set to a minimum of 1 and the setting can be increased in increments of 32 if horizontal binning is not enabled and increments of 16 if horizontal binning is enabled.</p> <p>If the value is set to 1, the starting pixel for the AOI will be 1. If the value is set to 33, the starting pixel for the AOI will be 33. And so on.</p> <p>The allowed range for this value can vary depending on how the area of interest length parameter is set. You should check the raw min and raw max fields of this register to determine the allowed range with the current configuration.</p> <p>The 2 bytes in this field are interpreted as follows:</p> <p>Byte 1 = Low byte of the starting pixel value</p> <p>Byte 1 = High byte of the starting pixel value</p> <p>See Section 6.2 on page 118 for more information about the AOI feature.</p>			
Field Name: Min	Offset: 0x0003	Size: 2 Bytes	Type: Read only
<p>Description: Minimum allowed integer value for the starting pixel setting. This field is updated to reflect limitations caused by the way any related features are set.</p> <p>The 2 bytes in this field are interpreted as follows:</p> <p>Byte 1 = Low byte of the min value</p> <p>Byte 1 = High byte of the min value</p>			
Field Name: Max	Offset: 0x0005	Size: 2 Bytes	Type: Read only
<p>Description: Maximum allowed integer value for the starting pixel setting. This field is updated to reflect limitations caused by the way any related features are set.</p> <p>The 2 bytes in this field are interpreted as follows:</p> <p>Byte 1 = Low byte of the max value</p> <p>Byte 1 = High byte of the max value</p>			
Field Name: Increment	Offset: 0x0007	Size: 2 Bytes	Type: Read only
<p>Description: An integer value indicating the increment for the starting pixel setting.</p> <p>The 2 bytes in this field are interpreted as follows:</p> <p>Byte 1 = Low byte of the increment</p> <p>Byte 1 = High byte of the increment</p>			

Area of Interest Length CSR

Register Base Address: 0x100A			
Field Name: Register Status	Offset: 0x0000	Size: 1 Byte	Type: Read only
<p>Description: The integer value in this field indicates the status of this control and status register:</p> <p>0x00 = The register is not available</p> <p>0x01 = The register is available and all related settings are OK</p> <p>0x80 = A value in the register is set out of range</p>			
Field Name: Length	Offset: 0x0001	Size: 2 Bytes	Type: Read/Write
<p>Description: Writing an integer to this field sets the length in pixels for the area of interest (AOI) feature.</p> <p>If horizontal binning is not enabled, the area of interest length can be set to a minimum of 256 and increased in increments of 32.</p> <p>If horizontal binning is enabled, the area of interest length can be set to a minimum of 128 and increased in increments of 16.</p> <p>If the value is set to 256, the length of the AOI will be 256. If the value is set to 288, the length of the AOI will be 288. And so on.</p> <p>The allowed range for this value can vary depending on how the area of interest starting pixel parameter is set. You should check the raw min and raw max fields of this register to determine the allowed range with the current configuration.</p> <p>The 2 bytes in this field are interpreted as follows:</p> <p>Byte 1 = Low byte of the length setting</p> <p>Byte 1 = High byte of the length setting</p> <p>See Section 6.2 on page 118 for more information about the AOI feature.</p>			
Field Name: Min	Offset: 0x0003	Size: 2 Bytes	Type: Read only
<p>Description: Minimum allowed integer value for the AOI length setting. This field is updated to reflect limitations caused by the way any related features are set.</p> <p>The 2 bytes in this field are interpreted as follows:</p> <p>Byte 1 = Low byte of the min value</p> <p>Byte 1 = High byte of the min value</p>			
Field Name: Max	Offset: 0x0005	Size: 2 Bytes	Type: Read only
<p>Description: Maximum allowed integer value for the AOI length setting. This field is updated to reflect limitations caused by the way any related features are set.</p> <p>The 2 bytes in this field are interpreted as follows:</p> <p>Byte 1 = Low byte of the max value</p> <p>Byte 1 = High byte of the max value</p>			
Field Name: Increment	Offset: 0x0007	Size: 2 Bytes	Type: Read only
<p>Description: An integer value indicating the increment for the AOI length setting.</p> <p>The 2 bytes in this field are interpreted as follows:</p> <p>Byte 1 = Low byte of the increment</p> <p>Byte 1 = High byte of the increment</p>			

Shading Mode CSR

Register Base Address: 0x2000			
Field Name: Register Status	Offset: 0x0000	Size: 1 Byte	Type: Read only
Description: The integer value in this field indicates the status of this control and status register: 0x00 = The register is not available 0x01 = The register is available and all related settings are OK 0x80 = A value in the register is set out of range			
Field Name: Mode	Offset: 0x0001	Size: 1 Byte	Type: Read/Write
Description: Writing an integer to this field sets the shading correction mode: 0x00 = Shading correction disabled 0x01 = Enable DSNU shading correction only 0x02 = Enable PRNU shading correction only 0x03 = Enable DSNU and PRNU shading correction See Section 6.3 on page 121 for more information about the shading correction feature.			

Shading Value Generate CSR

Register Base Address: 0x2100			
Field Name: Register Status	Offset: 0x0000	Size: 1 Byte	Type: Read only
Description: The integer value in this field indicates the status of this control and status register: 0x00 = The register is not available 0x01 = The register is available and all related settings are OK 0x02 = The generation process failed 0x80 = A value in the register is set out of range			
Field Name: Generate	Offset: 0x0001	Size: 1 Byte	Type: Read/Write
Description: Writing an integer to this field sets the shading correction mode: 0x00 = No generation 0x01 = Generate DSNU correction values 0x02 = Generate PRNU correction values and do not use DSNU correction during generation 0x03 = Generate PRNU correction values and use DSNU correction during generation See Section 6.3 on page 121 for more information about the shading correction feature.			

Test Image Mode CSR

Register Base Address: 0x1800			
Field Name: Register Status	Offset: 0x0000	Size: 1 Byte	Type: Read only
Description: The integer value in this field indicates the status of this control and status register: 0x00 = The register is not available 0x01 = The register is available and all related settings are OK 0x80 = A value in the register is set out of range			
Field Name: Mode	Offset: 0x0001	Size: 1 Byte	Type: Read/Write
Description: Writing an integer to this field sets the test image mode: 0x00 = Test images disabled 0x01 = Test image 1 enabled (fixed gray gradient) 0x02 = Test image 2 enabled (moving gray gradient) 0x03 = Test image 3 enabled (uniform black) 0x04 = Test image 4 enabled (uniform gray) See Section 6.4 on page 132 for more information about the test image feature.			

Line Stamp Mode CSR

Register Base Address: 0x2B00			
Field Name: Register Status	Offset: 0x0000	Size: 1 Byte	Type: Read only
Description: The integer value in this field indicates the status of this control and status register: 0x00 = The register is not available 0x01 = The register is available and all related settings are OK 0x80 = A value in the register is set out of range			
Field Name: Mode	Offset: 0x0001	Size: 1 Byte	Type: Read/Write
Description: Writing an integer to this field sets the line stamp mode: 0x00 = Line stamp off 0x01 = Line stamp on See Section 6.5 on page 136 for more information about the line stamp feature.			

Line Stamp Low Pixel Limit CSR

Register Base Address: 0x2B20			
Field Name: Register Status	Offset: 0x0000	Size: 1 Byte	Type: Read only
Description: The integer value in this field indicates the status of this control and status register: 0x00 = The register is not available 0x01 = The register is available and all related settings are OK 0x80 = A value in the register is set out of range			
Field Name: Low Pixel Limit	Offset: 0x0001	Size: 2 Bytes	Type: Read/Write
Description: Writing an integer to this field sets the low pixel limit for the line stamp feature. When the camera is set for 8 bit output, you should set the low pixel limit within a range from 0 (0x0000) to 255 (0x00FF). When the camera is set for 10 bit output, you should set the low pixel limit within a range from 0 (0x0000) to 1023 (0x03FF). When the camera is set for 12 bit output, you should set the low pixel limit within a range from 0 (0x0000) to 4095 (0x0FFF). The 2 bytes in this field are interpreted as follows: Byte 1 = Low byte of the low pixel limit Byte 1 = High byte of the low pixel limit See Section 6.5 on page 136 for more information about the line stamp feature and the low pixel limit.			
Field Name: Min	Offset: 0x0003	Size: 2 Bytes	Type: Read only
Description: Minimum allowed integer value for the low pixel limit. This field is updated to reflect limitations caused by the way any related features are set. The 2 bytes in this field are interpreted as follows: Byte 1 = Low byte of the min value Byte 1 = High byte of the min value			
Field Name: Max	Offset: 0x0005	Size: 2 Bytes	Type: Read only
Description: Maximum allowed integer value for the low pixel limit. This field is updated to reflect limitations caused by the way any related features are set. The 2 bytes in this field are interpreted as follows: Byte 1 = Low byte of the max value Byte 1 = High byte of the max value			
Field Name: Increment	Offset: 0x0007	Size: 2 Bytes	Type: Read only
Description: An integer value indicating the increment for the low pixel limit setting. The 2 bytes in this field are interpreted as follows: Byte 1 = Low byte of the increment Byte 1 = High byte of the increment			

Line Stamp High Pixel Threshold CSR

Register Base Address: 0x2B40			
Field Name: Register Status	Offset: 0x0000	Size: 1 Byte	Type: Read only
Description: The integer value in this field indicates the status of this control and status register: 0x00 = The register is not available 0x01 = The register is available and all related settings are OK 0x80 = A value in the register is set out of range			
Field Name: High Pixel Threshold	Offset: 0x0001	Size: 2 Bytes	Type: Read/Write
Description: Writing an integer to this field sets the high pixel threshold for the line stamp feature. When the camera is set for 8 bit output, you should set the high pixel threshold within a range from 0 (0x0000) to 255 (0x00FF). When the camera is set for 10 bit output, you should set the high pixel threshold within a range from 0 (0x0000) to 1023 (0x03FF). When the camera is set for 12 bit output, you should set the high pixel threshold within a range from 0 (0x0000) to 4095 (0x0FFF). The 2 bytes in this field are interpreted as follows: Byte 1 = Low byte of the high pixel threshold Byte 1 = High byte of the high pixel threshold See Section 6.5 on page 136 for more information about the line stamp feature and the high pixel threshold.			
Field Name: Min	Offset: 0x0003	Size: 2 Bytes	Type: Read only
Description: Minimum allowed integer value for the high pixel threshold. This field is updated to reflect limitations caused by the way any related features are set. The 2 bytes in this field are interpreted as follows: Byte 1 = Low byte of the min value Byte 1 = High byte of the min value			
Field Name: Max	Offset: 0x0005	Size: 2 Bytes	Type: Read only
Description: Maximum allowed integer value for the high pixel threshold. This field is updated to reflect limitations caused by the way any related features are set. The 2 bytes in this field are interpreted as follows: Byte 1 = Low byte of the max value Byte 1 = High byte of the max value			
Field Name: Increment	Offset: 0x0007	Size: 2 Bytes	Type: Read only
Description: An integer value indicating the increment for the high pixel threshold setting. The 2 bytes in this field are interpreted as follows: Byte 1 = Low byte of the increment Byte 1 = High byte of the increment			

Lookup Table Mode CSR

Register Base Address: 0x4100			
Field Name: Register Status	Offset: 0x0000	Size: 1 Byte	Type: Read only
Description: The integer value in this field indicates the status of this control and status register: 0x00 = The register is not available 0x01 = The register is available and all related settings are OK 0x80 = A value in the register is set out of range			
Field Name: Mode	Offset: 0x0001	Size: 1 Byte	Type: Read/Write
Description: Writing an integer to this field sets the lookup table mode: 0x00 = Lookup table disabled 0x01 = Lookup table enabled See Section 6.6 on page 141 for more information about the lookup table feature.			

Lookup Table Index CSR

Register Base Address: 0x4108			
Field Name: Register Status	Offset: 0x0000	Size: 1 Byte	Type: Read only
Description: The integer value in this field indicates the status of this control and status register: 0x00 = The register is not available 0x01 = The register is available and all related settings are OK 0x80 = A value in the register is set out of range			
Field Name: Lookup Table Index	Offset: 0x0001	Size: 2 Bytes	Type: Read/Write
Description: Writing an integer to this field selects an index in the lookup table. The 2 bytes in this field are interpreted as follows: Byte 1 = Low byte of the lookup table index Byte 1 = High byte of the lookup table index See Section 6.6 on page 141 for more information about the lookup table feature.			
Field Name: Min	Offset: 0x0003	Size: 2 Bytes	Type: Read only
Description: Minimum allowed integer value for the lookup table index. The 2 bytes in this field are interpreted as follows: Byte 1 = Low byte of the min value Byte 1 = High byte of the min value			
Field Name: Max	Offset: 0x0005	Size: 2 Bytes	Type: Read only
Description: Maximum allowed integer value for the lookup table index. The 2 bytes in this field are interpreted as follows: Byte 1 = Low byte of the max value Byte 1 = High byte of the max value			
Field Name: Increment	Offset: 0x0007	Size: 2 Bytes	Type: Read only
Description: An integer value indicating the increment for the lookup table index. The 2 bytes in this field are interpreted as follows: Byte 1 = Low byte of the increment Byte 1 = High byte of the increment			

Lookup Table Value CSR

Register Base Address: 0x4111			
Field Name: Register Status	Offset: 0x0000	Size: 1 Byte	Type: Read only
Description: The integer value in this field indicates the status of this control and status register: 0x00 = The register is not available 0x01 = The register is available and all related settings are OK 0x80 = A value in the register is set out of range			
Field Name: Lookup Table Value	Offset: 0x0001	Size: 1 Byte	Type: Read/Write
Description: Writing an integer to this field enters a value into the camera's lookup table at the index currently specified by the lookup table index CSR. See Section 6.6 on page 141 for more information about the lookup table feature.			
Field Name: Min	Offset: 0x0002	Size: 1 Byte	Type: Read only
Description: Minimum allowed integer value for a lookup table value.			
Field Name: Max	Offset: 0x0003	Size: 1 Byte	Type: Read only
Description: Maximum allowed integer value for a lookup table value.			
Field Name: Increment	Offset: 0x0004	Size: 1 Byte	Type: Read only
Description: An integer value indicating the increment for the lookup table value.			

Camera Reset CSR

Register Base Address: 0x0B00			
Field Name: Register Status	Offset: 0x0000	Size: 1 Byte	Type: Read only
Description: The integer value in this field indicates the status of this control and status register: 0x00 = The register is not available 0x01 = The register is available and all related settings are OK 0x80 = A value in the register is set out of range			
Field Name: Reset	Offset: 0x0001	Size: 1 Byte	Type: Read/Write
Description: Writing an integer value of 1 (0x01) to this field will initiate a camera reset. The reset behavior of the camera is similar to power up behavior.			

Serial Communication CSR

An RS-644 serial connection is integrated into the Camera Link interface between the frame grabber installed in your computer and the camera. The serial connection is used to issue commands to the camera for changing modes and parameters. You can use the serial communication CSR to set the bitrate for the camera's RS-644 serial port.

The default setting is 9600 bps.

The setting is changed immediately after the successful receipt of this command.

Register Base Address: 0x0D00			
Field Name: Register Status	Offset: 0x0000	Size: 1 Byte	Type: Read only
Description: The integer value in this field indicates the status of this control and status register: 0x00 = The register is not available 0x01 = The register is available and all related settings are OK 0x80 = A value in the register is set out of range			
Field Name: Bitrate	Offset: 0x0001	Size: 1 Byte	Type: Read/Write
Description: Writing an integer to this field sets the bit rate: 0x0F = 9600 bps (default) 0x11 = 19200 bps 0x12 = 38400 bps 0x13 = 57600 bps 0x14 = 115200 bps See Section 2.9.1 on page 37 and Section 7.3 on page 196 for more information about serial communication.			



Note

When changing a setting for serial communication, use the following procedure:

1. Issue the write command with the new setting.
2. Wait one second.
3. Change the setting on the frame grabber's RS-644 serial port.
4. Resume communication.

The RS-644 serial port on some Camera Link frame grabbers will only support a bitrate of 9600. If you are using a Camera Link frame grabber, check the grabber's documentation before attempting to change the bitrate.

At reset or power off/on, the camera returns to the 9600 bps setting.

7.2.3 Bulk Data and the Bulk Data Control and Status Registers

The term “bulk data” refers to a collection of values used by the camera as a block. A configuration set (see Section 6.12 on [page 149](#)) is an example of one type of bulk data. A single configuration set contains values for all of the normal parameter settings needed to configure the camera and the values within a configuration set are used by the camera as a block. A set of shading values (see Section 6.3 on [page 121](#)) is an examples of another type of bulk data. The set of shading values contains all of the values needed to do shading correction, and the camera uses the shading values as a block.

The camera has a file system similar to the file system used on PCs. The camera can store blocks of bulk data such as a configuration set or the set of shading values in named files within the camera’s non-volatile memory. The camera’s bulk data control and status registers (CSRs) are used to save blocks of bulk data to files in the non-volatile memory. For example, you can use the configuration set bulk data control register to store the settings from the current work configuration set in a named file.

For sprint cameras, there are two types of bulk data: configuration sets and shading values. There is a separate bulk data control and status register for each type of bulk data. The configuration set bulk data CSR is used to work with configuration sets, the shading value CSR is used to work with shading values.

By writing to fields within a bulk data CSR you can do things such as saving a block of bulk data to a file in the non-volatile memory, copying a saved bulk data file from the camera to a PC and creating a list of existing saved bulk data files. Section 7.2.3.4 on [page 194](#) lists the bulk data CSRs and provides a general description of the use of each field within the registers.

The best way to understand the use of the bulk data CSRs is to read about the different tasks that you can perform with them. Section 7.2.3.1 on [page 189](#) describes the tasks and procedures that are normally performed by manipulating the Configuration Set Bulk Data CSR. Section 7.2.3.2 on [page 190](#) describes the tasks and procedures that are normally performed by manipulating the Shading Values Bulk Data CSR.

7.2.3.1 Using the Configuration Set Bulk Data CSR

Saving the Work Configuration Set to a User Set File

As described in Section 6.12 on [page 149](#), the work configuration set resides in the camera's volatile memory. Assume that you want to save the parameter values in the current work set to the *UserSet01* file in the camera's non-volatile memory. To do so, you would follow this procedure:

1. Use a binary write command to write the file name *UserSet01* to the Name field of the configuration set bulk data CSR (see [page 194](#)).
2. Use a binary write command to set the value of the Control field of the configuration set bulk data CSR to 0x06. Setting the value to 0x06 initiates a copy function.

This procedure will copy the current work set settings from the camera's volatile memory into a file called *UserSet01* in the non-volatile memory. Note that any existing data in the file will be overwritten.

Sample code that illustrates how to save a bulk data file is available from Basler (see [Section 7.4 on page 204](#)).



Note

There are four files available in the non-volatile memory to hold saved user configuration sets: *UserSet01*, *UserSet02*, *UserSet03*, or *UserSet04*. You must use one of these file names when you save a user configuration set.

Activating a User Set File or the Factory Set File

The process of “activating” a user set file or the factory set file, accomplishes two things:

- The values from the activated file are immediately copied into the work set in the camera's volatile memory. The camera will now actively use the configuration values that were copied into the work set.
- A link is created between the activated file and the camera's volatile memory. The values in the activated file will automatically be copied into the work set whenever the camera is powered up or reset.

As an example, assume that you have saved a configuration set to the *UserSet01* file and that you want to activate this file. To do so, you would follow this procedure:

1. Use a binary write command to write the file name *UserSet01* to the Name field of the configuration set bulk data CSR (see [page 194](#)).
2. Use a binary write command to set the value of the Control field in the configuration set bulk data CSR to 0x05. Setting the value to 0x05 initiates an activate function.

This procedure would find the *UserSet01* file in the non-volatile memory and would copy the values in the file into the camera's volatile memory. It would also create a link to the file so that the values in the file would be loaded into volatile memory after a reset or a power up.

If you want to activate the factory set, you would following a similar procedure but use *FactorySet* as the file name.

Sample code that illustrates how to activate a saved bulk data file is available from Basler (see Section 7.4 on [page 204](#)).

7.2.3.2 Using the Shading Values Bulk Data CSR

Activating the User Shading Values File or the Factory Shading Values File

The process of “activating” the user shading value file or the factory shading value file, accomplishes two things:

- It copies the values from the file into the camera's volatile memory. This means that the values will now be actively used by the camera.
- It creates a link to the activated file. If the camera is reset or if it is powered off and then back on, the shading values from the activated file will be loaded into volatile memory of the camera and actively used by the camera when shading correction is enabled.

As an example, assume that you have generated user shading values and that you want to activate the user shading values file. To do so, you would follow this procedure:

1. Use a binary write command to write the file name *UserShading* to the Name field of the shading value bulk data CSR (see [page 195](#)).
2. Use a binary write command to set the value of the Control field in the shading value bulk data CSR to 0x05. Setting the value to 0x05 initiates an activate function.

This procedure would find the *Usershading* file in the non-volatile memory and would copy the values in the file into the camera's volatile memory. It would also create a link to the file so that the values in the file would be loaded into volatile memory after a reset or a power up.

If you want to activate the factory shading value file, you would following a similar procedure but use *FactoryShading* as the file name.

Sample code that illustrates how to activate a saved bulk data file is available from Basler (see Section 7.4 on [page 204](#)).

Copying the Factory Shading Values File into the User Shading Values File

Assume that you want to copy the shading values in the factory shading values file into the user shading values file. To do so, you would follow this procedure:

1. Use a binary write command to write the file name *UserShading* to the Name field of the shading value bulk data CSR (see [page 195](#)).
2. Use a binary write command to set the value of the Control field of the configuration set bulk data CSR to 0x06. Setting the value to 0x06 initiates a copy function.

This procedure will copy the contents of the factory shading values file into the user shading values file. Note that any existing data in the user shading values file will be overwritten.

Sample code that illustrates how to create a bulk data file is available from Basler (see [Section 7.4](#) on [page 204](#)).

7.2.3.3 General Procedures for Working with Bulk Data CSRs

Enumerating Bulk Data Files

Bulk data file enumeration allows you to look through a list of the bulk data files that currently contain saved parameters.

As an example, assume that you want to see a list of all of the configuration set files that currently contains saved parameters. To do so, you would follow this procedure:

1. Use a binary write command to set the value of the Control field in the configuration set bulk data CSR (see [page 194](#)) to 0x00. Setting the value to 0x00 initiates an enumerate function.
2. Use a binary read command to read the Name field of the configuration set bulk data CSR. This is the name of a configuration set file that contains saved data.
3. Use a binary read command to read the value in the Info field of the configuration set bulk data CSR.
 - a. If the value is 0x00, it means that the file contains saved parameters and it is not an activated file. Continue to step 4.
 - b. If the value is 0x04, it means that the file contains saved parameters and it is an activated file. Continue to step 4.
 - c. If the value is 0x01 no more configuration set files with saved parameters exist. Exit the procedure.
4. Use a binary write command to set the value of the Control field in the configuration set bulk data CSR to 0x01. Setting the value to 0x01 initiates an enumerate next function.
5. Return to step 2.

This procedure would list all of the configuration set bulk data files that contain a saved parameter set.

If you wanted to enumerate the existing saved shading value file, you would use a similar procedure but you would write to and read from the shading value bulk data CSR instead.

Sample code that illustrates how to enumerate bulk data files is available from Basler (see [Section 7.4](#) on [page 204](#)).

Downloading a Bulk Data File from the Camera to a PC

You can download a bulk data file from the camera's non-volatile memory to your host PC.

As an example, assume that you have saved a configuration set to the *UserSet02* file and that you want to download this file from the camera to your host PC. To do so, you would follow this procedure:

Use a binary write command to write the file name *UserSet02* to the Name field of the configuration set bulk data CSR.

1. Use a binary read command to read the Size field of the configuration set bulk data CSR.
2. If the file contains saved data, this field will tell you the file size. If the file does not contain saved data, this field will be 0.
3. Use a binary write command to set the value of the Control field in the configuration set bulk data CSR to 0x02. Setting the value to 0x02 places the camera in read mode.
4. Use a binary command to do a bulk data read from the camera. The binary command must have the following characteristics:

OpCode = 0x05 (This OpCode makes the binary command a bulk data read)

DataLen = the number of bytes to be read (Max is 255 characters*)

Address = 0x281B (Base address for the configuration set bulk data CSR plus the offset for the Data field)

Data = none

5. You will receive a bulk data response frame from the camera. (The amount of data in the response will be as specified by the DataLen in step 4.)
6. Use a binary read command to read the value in the Info field of the configuration set bulk data CSR.
 - a. If the value is 0x01 no more data exists in the file. Exit the procedure.
 - b. If the value is 0x00, more data exists and this is not an activated file. Return to step 4.
 - c. If the value is 0x04, more data exists and this is an activated file. Return to step 4.

* Up to 255 characters can be read with a single binary bulk data read command. If the file is larger than 255 characters, repeated binary bulk data read commands are required. When repeated bulk data read commands are required, the file is read sequentially with each read command starting where the previous read stopped.

This procedure will download the data in the file to the host computer.

If you want to download a shading values bulk data file to the host PC, you would use a similar procedure but you would use the shading values bulk data CSR instead.

Sample code that illustrates how to download a bulk data file is available from Basler (see Section 7.4 on [page 204](#)).

Uploading a Bulk Data File from a PC to the Camera

You can upload a bulk data file from your host PC to the camera's non-volatile memory.

As an example, assume that you previously downloaded a saved configuration set file named *UserSet02* to your PC. Also assume that you now want to upload this file from your host PC to a camera. To do so, you would follow this procedure:

1. Use a binary write command to write the file name *UserSet02* to the Name field of the configuration set bulk data CSR.
 2. Use a binary write command to set the value of the Control field in the configuration set bulk data CSR to 0x03. Setting the value to 0x03 places the camera in write mode.
 3. Use a binary command to do a bulk data write to the camera. The binary write command must have the following characteristics:
 - OpCode = 0x04 (This OpCode makes the command a bulk data write)
 - DataLen = the number of bytes to be written (Max is 255 characters*)
 - Address = 0x281B (Base address for the configuration set bulk data CSR plus the offset for the Data field)
 - Data = Bytes to be written
 4. Repeat step 3 as many times as needed to write all of the data from the PC to the camera.
 5. Close the bulk data file in the camera. To close the file, use a binary write command to set the value of the Control field in the configuration set bulk data CSR to 0x02. Setting the value to 0x02 places the camera in read mode and closes the file.
- * Up to 255 characters can be written with a single binary bulk data write command. If the file is larger than 255 characters, repeated binary bulk data write commands are required. When repeated bulk data write commands are required, the file is written sequentially with each write command starting where the previous write stopped.

This procedure will upload the data in the file to the camera.

If you want to upload a user shading value bulk data file from a PC to a camera, you would use a similar procedure but you would use the shading value bulk data CSR instead.

Sample code that illustrates how to upload a bulk data file is available from Basler (see Section 7.4 on [page 204](#)).



Note

When you upload a bulk data file from the PC to the camera, it will overwrite any existing data in the camera file with the same name. For example, if you upload a configuration set file called *UserSet02* from a PC to a camera, it will overwrite the existing contents of the *UserSet2* file in the camera.

You can download the factory configuration set file from the camera to the PC, but you can't upload the factory configuration set from the PC to the camera. The factory configuration set in the camera is protected and can't be overwritten.

7.2.3.4 Bulk Data Control and Status Register Details

Configuration Set CSR

See Section 7.2.3.1 on [page 189](#) for information about using the configuration set bulk data control register.

Register Base Address: 0x2800			
Field Name: Register Status	Offset: 0x0000	Size: 1 Byte	Type: Read only
Description: The integer value in this field indicates the status of this control and status register: 0x00 = The register is not available 0x01 = The register is available and all related settings are OK 0x80 = A value in the register is set out of range			
Field Name: Control	Offset: 0x0001	Size: 1 Byte	Type: Read/Write
Description: Writing an integer to this field selects a bulk data control function: 0x00 = Enumerate 0x01 = ENext 0x02 = Read 0x03 = Write 0x04 = Erase 0x05 = Activate 0x06 = Copy			
Field Name: Info	Offset: 0x0002	Size: 1 Byte	Type: Read only
Description: If you are performing a bulk read or write operation, this field will indicate when no more data exists: 0x00 = More data exists 0x01 = No more data exists 0x02 = File operation error 0x04 = This is an activated file			
Field Name: File Name	Offset: 0x0003	Size: 20 Bytes	Type: Read/Write
Description: Character string indicating the name of the bulk data file. The field contains 20 characters (left aligned and zero padded). Only the following names are allowed: FactorySet, UserSet01, UserSet02, UserSet03, and UserSet04. UserSet03 and UserSet04 are not allowed for 8k cameras.			
Field Name: Size	Offset: 0x0017	Size: 4 Bytes	Type: Read only
Description: If the file name refers to an already existing bulk data file, this field will contain the file size in bytes. Otherwise, the field contains zeros.			
Field Name: Data	Offset: 0x001B	Size: Variable	Type: Read/Write
Description: Byte sized register that is used to sequentially write to or read from a bulk data file.			

Shading Values CSR

See Section 7.2.3.2 on [page 190](#) for information about using the shading values bulk data control registers.

Register Base Address: 0x2A00			
Field Name: Register Status	Offset: 0x0000	Size: 1 Byte	Type: Read only
Description: The integer value in this field indicates the status of this control and status register: 0x00 = The register is not available 0x01 = The register is available and all related settings are OK 0x80 = A value in the register is set out of range			
Field Name: Control	Offset: 0x0001	Size: 1 Byte	Type: Read/Write
Description: Writing an integer to this field selects a bulk data control function: 0x00 = Enumerate 0x01 = ENext 0x02 = Read 0x03 = Write 0x04 = Erase 0x05 = Activate 0x06 = Copy			
Field Name: Info	Offset: 0x0002	Size: 1 Byte	Type: Read only
Description: If you are performing a bulk read or write operation, this field will indicate when no more data exists: 0x00 = More data exists 0x01 = No more data exists 0x02 = File operation error 0x04 = This is an activated file			
Field Name: File Name	Offset: 0x0003	Size: 20 Bytes	Type: Read/Write
Description: Character string indicating the name of the bulk data file. The field contains 20 characters (left aligned and zero padded). Only the following names are allowed: FactoryShading, UserShading.			
Field Name: Size	Offset: 0x0017	Size: 4 Bytes	Type: Read only
Description: If the file name refers to an already existing bulk data file, this field will contain the file size in bytes. Otherwise, the field contains zeros.			
Field Name: Data	Offset: 0x001B	Size: Variable	Type: Read/Write
Description: Byte sized register that is used to sequentially write to or read from a bulk data file.			

7.3 Using Binary Read/Write Commands

As explained in Section 7.2 on [page 157](#), each camera has control and status registers with one or more fields that are used to set the values for parameters associated with a camera feature. For example, the gain control and status register has two fields that can be used to set the camera's gain (see Section 6.1 on [page 115](#)). By writing values to fields in the control registers, you configure the camera and control how it operates. By reading values from fields in the control registers, you can determine how the camera is currently configured.

Each camera also has inquiry registers with fields that contain basic information such as the camera's serial number and software version numbers. By reading values in the inquiry register fields, you can determine some basic information about the camera.

A "binary read/write command" protocol has been developed for use with the camera.

You can read the data in a register field by sending a binary read command to the camera. For example, you can use a read command to determine the current value of the Mode field of the Test Image Mode control and status register (see [page 179](#)). When you issue a read command to the camera, the camera responds by sending the requested data back to the host computer.

You can write data to a register field by sending a write command to the camera. For example, you can use a write command to change the value of the Mode field of the Test Image control register. When you issue a write command to the camera, the value in the register field will be replaced and the camera will send a write response back to the host computer.

Each field within a control register or an inquiry register has a specific memory address. When you issue a binary read or a binary write command, the address for the field you want to work with is included as part of the command. Section 7.3.1 on [page 197](#) describes the binary read/write command format in detail. Sample code that illustrates how to use binary read and write commands is available from Basler (see Section 7.4 on [page 204](#)).

Binary read/write commands are issued to the camera via the RS-644 serial connection in the Camera Link interface between the frame grabber and the camera. A standard application programmer's interface (API) for asynchronous serial reading and writing via the RS-644 port on the frame grabber has been defined in the Camera Link standard (Appendix B, API Functions). All Camera Link compatible frame grabbers provide a software library (.dll file) named `clser***.dll` where `***` is specific to the frame grabber vendor. There are four functions exported by that DLL:

- `clSerialNit` - Initialize the serial communication for a specific board.
- `clSerialRead` - Read bytes from the camera.
- `clSerialWrite` - Write bytes to the camera.
- `clSerialClose` - Close the serial communication.

To execute the binary programming commands, you can call up the functions exported by the DLL.



Note

When the camera is powered on or when a camera reset is performed, your PC may receive one random character on the serial interface. We recommend clearing the serial input buffers in your PC after a camera power on or reset.

7.3.1 The Binary Read/Write Command Protocol

With the binary read/write command protocol, data is placed into a “frame” and sent to the camera. When the frame is received, it is checked for validity. If valid, the data is extracted from the frame and the command is executed.

This section describes the basic layout of a binary command frame. Figure 50 shows a graphical representation of the fields within a binary command frame. The text below the graphic describes each field of the command frame in detail.

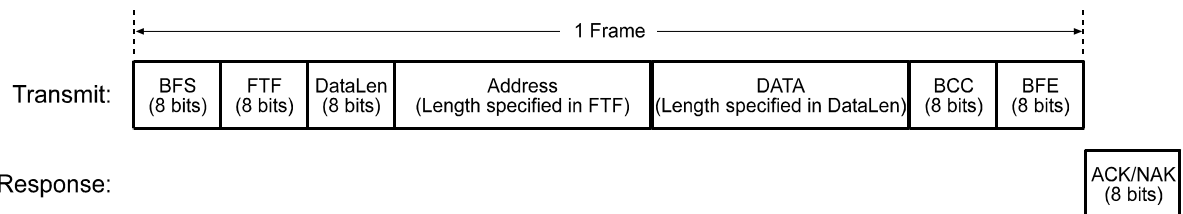

Fig. 50: Representation of a Command Frame and Response

BFS Binary Frame Start field
Identifies the start of a binary frame.
Size = 1 byte
The value of the BFS byte is always 0x01.

FTF Frame Type and Format field
Identifies the frame type and format.
Size = 1 byte
The bits in the FTF field are assigned as follows:

7	6	5	4	3	2	1	0
OpCode					BCC-Code	AddrLen	

The MSB of the FTF field is on the left (highest bit of the opcode) and the LSB of the field is on the right (lowest bit of the address length).

The value in the OpCode portion of the FTF field defines the function of the binary command, that is, whether it is a read command or a write command. The following OpCodes are available:

OpCode	Function
0b00000	This is a write command used to write a single setting to the camera.
0b00001	This is a read command used to read a single setting from the camera.
0b00010	This is a read response frame without an address field. (The AddrLen bits are "don't care").
0b00100	This is a bulk write command used to upload a file into the camera.
0b00101	This is a bulk read command used to download a file from the camera.
0b00110	This is a bulk read response frame without an address field. (The AddrLen bits are "don't care")

The BCC-Code portion of the FTF field indicates the presence of a Block Check Character (BCC). (The use of a BCC is optional.)

BCC-Code	Function
0b0	This frame (and also the response frame) contains no BCC field.
0b1	This frame (and also the response frame) contains a BCC field.

The AddrLen portion of the FTF field indicates the size of the command and status register (CSR) address to which the command is being sent.

AddrLen	Length of the Address Field
0b00	16 bits (= 2 bytes)
0b01	32 bits (= 4 bytes)
0b10	48 bits (= 6 bytes)
0b11	64 bits (= 8 bytes)

All CSR addresses are 16 bits.

Example of an FTF field:

Assume that you are issuing a write command, that you are using a BCC and that the CSR address you are writing to is a 16 bit address. In this case, the OpCode bits would be 0b00000, the BCC-Code bit would be 0b1 and the AddrLen bits would be 0b00. This would result in a binary value of 0b00000100, which translates to a hex value of 0x04 for the FTF field.

DataLen	<p>Data Length field</p> <p>For read commands, the DataLen field indicates the number of bytes to read from the given CSR address.</p> <p>For write commands, the DataLen field indicates the number of bytes contained in the Data field.</p> <p>Size = 1 byte</p> <p>Range of possible settings: 0 to 255.</p> <p>DataLen = 0 will result in an ACK, but no further command will be executed.</p>
Address	<p>Address field</p> <p>For read commands, indicates the CSR address for the read.</p> <p>For write commands, indicates the CSR address for the write.</p> <p>Size = Number of bytes indicated in the AddrLen portion of the FTF field</p>
Data	<p>Data field</p> <p>For read commands, this field contains no data.</p> <p>For write commands, this field contains the data to be written to the CSR.</p> <p>Size for read commands = 0 bytes.</p> <p>Size for write commands = the number of bytes indicated in the DataLen field of the frame.</p>
BCC	<p>Block Check Character field</p> <p>The use of a block check character in read/write commands is optional.</p> <p>If bit 2 of the FTF field is 0, the BCC is not used and the BCC field will contain no data.</p> <p>If bit 2 of the FTF field is 1, the BCC field will contain the block check character.</p> <p>Size = 0 bytes if bit 2 of the FTF field is 0 1 byte if bit 2 of the FTF field is 1</p> <p>The block check character is the exclusive-or sum (XOR sum) of the bytes in the FTF, DataLen, Address and Data fields (see Section 7.3.2.3 on page 203).</p>
BFE	<p>Binary Frame End field</p> <p>Identifies the end of a binary frame.</p> <p>Size = 1 byte</p> <p>The value of the BFE byte is always 0x03.</p>
ACK/NAK Response	<p>Positive frame acknowledge/negative frame acknowledge</p> <p>Size = 1 byte</p> <p>The value for a positive frame acknowledgement (ACK) is 0x06 and for a negative frame acknowledgement (NAK) is 0x15.</p>

**Note**

All values are formatted as little endian (Intel format).

7.3.1.1 Error Checking and Responses

ACK/NAK

When the camera receives a frame, it checks to see if the order of the bytes in the frame is correct. If the FTF field indicates that the frame includes a BCC, the camera checks to see if the XOR sum of the relevant frame fields matches the block check character. The camera also checks to see if the number of bytes in the data field is equal to the number specified in the DataLen field.

If all checks are correct, an ACK is sent to the host. If any check is incorrect, a NAK is sent.

Byte Timeouts

The camera checks the time between the receipt of each byte in the frame. If the time between any two bytes exceeds 0.5 seconds, the camera enters a “garbage state” and discards any more incoming bytes. The camera remains in this state until it sees a new BFS.

Read Commands

In the normal case, when a read command is sent to the camera, the camera responds with an ACK and a returned frame. The returned frame will contain the data requested.

If the camera receives a read command with an unknown or invalid address in the Address field of the frame, it will respond with an ACK but will send no frame.

If the host sends a read command and gets no ACK/NAK, the host can assume that no camera is present or the camera is in a “garbage state” for some reason.

If the host sends a read command and gets an ACK/NAK but does not receive a frame within 500 ms, the host can assume that there was a problem with the read command.

Write Command

In the normal case, when a write command is sent to the camera, the camera responds with an ACK.

If the camera receives a write command with an unknown or invalid address in the Address field of the frame, it will respond with an ACK but will not perform the write.

After a write command has been issued by the host, the host can verify the write by issuing a corresponding read command and checking that the returned data is as expected (unless the address is “write-only”). The host can read the Camera Status fields in the Camera Status inquiry register (see [page 162](#)) and check the returned data to see if an error condition has been detected.



Note

For many of the write commands listed in the tables on [page 166](#) through [page 187](#), only data within a specified range or a specified group of values is valid. If the data in a write command is not within the allowed range or specified group of allowed values, the camera **will not** execute the write command.

7.3.2 Basic Read/Write Command Explanations

7.3.2.1 Read Command

This section includes a text description the hex digits included in a command message used to read the Status field of the Test Image Mode CSR (see [page 179](#)). The intent of this section is to give you a basic understanding of the elements included in a read command. Sample code that illustrates how to send a read command is available from Basler (see Section 7.4 on [page 204](#)).

The hex digits included in the read command are:

0x01, 0x0C, 0x01, 0x00, 0x18, 0x01, 0x03

0x01 is the BFS field.

The value in the BFS field is always 0x01.

0x0C is the FTF field.

The hex value of 0x0C in the FTF field converts to a binary value of 0b00001100.

Bits 7 through 3 of the binary value indicate the OpCode. As shown in the OpCode table on [page 198](#), an OpCode value of 0b00001 indicates that this is a read command frame.

Bit 2 indicates the presence or absence of a BCC in the frame. As shown in the OpCode table, when this bit is set to 0b1, it indicates that a BCC is present.

Bits 1 and 0 indicate the AddrLen. As shown in the OpCode table, a value of 0b00 for the AddrLen indicates that the address portion of this frame contains a 16-bit address. If you check the table on [page 179](#), you will find that the address for the Status field of the Test Image Mode CSR is 0x1800, a 16-bit address. (You are free to use any supported AddrLen as long as the CSR address will fit into it.)

0x01 is the DataLen field.

This field indicates the data size in bytes that will be transferred by using this read command. As shown in the table on [page 179](#), the data size for the Status field of the Test Image Mode CSR is 1 byte.

(Note that for read commands, the data size specified in the DataLen field represents the number of bytes of data that you expect to see in the response frame. No data bytes are actually included in the read command.)

0x00, 0x18 is the Address field (in little endian).

This field indicates the CSR address from which the data bytes will be read.

The little endian values of 0x00, 0x18 in the address field translate to an address of 0x1800. If you check the table on [page 179](#), you will find that 0x1800 is the address for the Status field of the Test Image Mode CSR.

0x15 is the BCC field.

See Section 7.3.2.3 on [page 203](#) for instructions on calculating a BCC.

(Note that the use of a BCC is optional. In this example, we assume that a BCC is used.)

0x03 is the BFE.

The value in the BFE field is always 0x03.

7.3.2.2 Write Command

This section includes a text description the hex digits included in a command message used to write a value of 0x01 to the Mode field of the Test Image Mode CSR (see [page 179](#)). The intent of this section is to give you a basic understanding of the elements included in a write command. Sample code that illustrates how to send a write command is available from Basler (see [Section 7.4 on page 204](#)).

The hex digits included in the write command are:

0x01, 0x04, 0x01, 0x01, 0x18, 0x01, 0x1D, 0x03

0x01 is the BFS field.

The value in the BFS field is always 0x01.

0x04 is the FTF field.

The hex value of 0x04 in the FTF field converts to a binary value of 0b00000100.

Bits 7 through 3 of the binary value indicate the OpCode. As shown in the OpCode table on [page 198](#), an OpCode value of 0b00000 indicates that this is a write command frame.

Bit 2 indicates the presence or absence of a BCC in the frame. As shown in the OpCode table, when this bit is set to 0b1, it indicates that a BCC is present.

Bits 1 through 0 indicate the AddrLen. As shown in the OpCode table, a value of 0b00 for the AddrLen indicates that the Address field in this frame contains a 16-bit address. If you check the table on [page 179](#), you will find that the address for the Mode field of the Test Image Mode CSR is 0x1801, a 16-bit address. (You are free to use any supported AddrLen as long as the CSR address will fit into it.)

0x01 Is the DataLen field.

This field indicates the data size in bytes that will be transferred by using this write command. As shown in the table on [page 179](#), the data size for the Mode field of the Test Image Mode CSR is 1 byte.

0x01, 0x18 is the Address field in little endian.

This field indicates the CSR address to which the data bytes will be written.

The little endian values of 0x01, 0x18 in the address field translate to an address of 0x1801. If you check the table on [page 179](#), you will find that 0x1801 is the address for the Mode field the Test Image Mode CSR. (The address for any field within a CSR is equal to the base address for the CSR plus the offset for the CSR field. In this case, the base address of the Test Image Mode CSR is 1800 and the offset for the Mode field is 0001. This results in an address of 1801 for the Mode field.)

0x01 is the Data field.

This field contains the data that must be written to the register in order to activate Test Image One (see the table on [page 179](#)).

0x1D is the BCC field.

See [Section 7.3.2.3 on page 203](#) for instructions on calculating a BCC.

(Note that the use of a BCC is optional. In this example, we assume that a BCC is used.)

0x03 is the BFE field.

The value in the BFE field is always 0x03.

7.3.2.3 Calculating the Block Check Character

The use of a block check character (BCC) in camera commands is optional (see Section 7.3.1 on [page 197](#)). If you choose to use a BCC, the BCC will be the exclusive-or sum (XOR sum) of the bytes in the FTF field, the DataLen field, the Address field and the Data field of the command frame. For the write command example shown in Section 7.3.2.2 on [page 202](#), the block check character is 0x18. Let's consider how this block check character was calculated.

Calculating XOR sums is most easily understood when numbers are shown in their binary form, so in the example calculations shown below, the hexadecimal digits in our command have been converted to binary.

To find the XOR sum of two binary numbers, you add the two digits in each column using the following rules:

If both digits are 0, the result is 0.

If both digits are 1, the result is 0.

If one of the digits is a 1 and the other is a 0, the result is 1.

With all of this in mind, here is how the check digit for the write command shown in Section 7.3.2.2 on [page 202](#) would be calculated:

0 0 0 0 0 1 0 0 = the binary representation of 0x04 (FTF)

0 0 0 0 0 0 0 1 = the binary representation of 0x01 (DataLen)

0 0 0 0 0 1 0 1 = XOR sum

0 0 0 0 0 1 0 1 = Previous XOR Sum

0 0 0 0 0 0 0 1 = the binary representation of 0x01 (Address Byte 1)

0 0 0 0 0 1 0 0 = New XOR sum

0 0 0 0 0 1 0 0 = Previous XOR sum

0 0 0 1 1 0 0 0 = the binary representation of 0x18 (Address Byte 2)

0 0 0 1 1 1 0 0 = New XOR sum

0 0 0 1 1 1 0 0 = Previous XOR Sum

0 0 0 0 0 0 0 1 = the binary representation of 0x01 (Data)

0 0 0 1 1 1 0 1 = Final XOR sum

0 0 0 1 1 1 0 1 = 0x1D = the block check character

7.4 Binary Command Sample Code

Sample code that illustrates how to use binary commands with sprint cameras is available at the Basler web site. Please look for the Binary Protocol II programming sample at:

<http://www.baslerweb.com>

8 Troubleshooting and Support

This section outlines the resources available to you if you need help working with your camera. It also provides some basic troubleshooting information that you can use to solve problems.

8.1 Tech Support Resources

The troubleshooting resources in this section of the manual will help you to find the cause of many common problems. If you need more assistance, you can contact the Basler technical support team for your area. Technical support contact information is located in the title pages of this manual.

You will also find helpful information such as frequently asked questions, downloads, and application notes on the Basler website at:

www.baslerweb.com/indizes/beitrag_index_en_22089.html

If you do decide to contact Basler technical support, please take a look at the form that starts on [page 215](#) before you call. Filling out this form will help make sure that you have all of the information the technical support team needs to help you with your problem.

You will also find helpful information such as frequently asked questions, downloads, and technical notes at our website: www.baslerweb.com.

8.2 Obtaining an RMA Number

Whenever you want to return material to Basler, you must request a Return Material Authorization (RMA) number before sending it back. The RMA number **must** be stated in your delivery documents when you ship your material to us! Please be aware that if you return material without an RMA number, we reserve the right to reject the material.

You can find detailed information about how to obtain an RMA number on the Basler website at: www.baslerweb.com/beitraege/beitrag_en_79701.html

8.3 Fault Finding Using the Camera LED

During bootup, the camera loads firmware and performs initial self checks. Once bootup is complete, the camera performs a continuous series of self checks. If an error condition is detected, the LED will begin to flash. The number of flashes indicate the detected error as shown in Table 30.

If several error states are present, the LED outputs the error code that has the highest priority.

To get more information about the camera's current condition, you can check the camera status as described in Section 6.10 on [page 148](#).

LED	Description	Priority
LED is not lit	Power to the camera is not present or the input voltage is too low (see Section Section 2.5 on page 30 and Section 6.8 on page 145).	
LED is solid green for several seconds, flashes orange and then becomes solid orange	This is the normal LED sequence at power on or after a camera reset.	
Solid orange	The camera has power and is OK.	-
LED flashes with gradually increasing frequency	Indicates that the camera is busy performing a normal operation such as generating shading tables. When the operation is complete, the flashing stops.	-
Continuous red flashing	An overvoltage condition has been detected (see Section 6.8 on page 145).	1 (highest)
Continuous fast orange flashing	General error. Please contact Basler technical support.	2
Continuous slow orange flashing	One of the following errors is present: <ul style="list-style-type: none"> ■ No FPGA firmware is available. ■ Firmware available but error when booting the FPGA. Please contact Basler technical support.	3
Repeated pattern of 6 slow orange flashes	An erroneous parameter set has been loaded. Load another parameter set.	4
Repeated pattern of 5 slow orange flashes	Parameter error. For example, a parameter is set out of range or to a value that is not valid.	5

Table 30: Camera Status Indicators

LED	Description	Priority
Repeated pattern of 4 slow orange flashes	<p>One of the following errors is present:</p> <ul style="list-style-type: none"> ■ A byte time-out has occurred (see Section 7.3.1.1 on page 200). ■ Invalid OpCode in a read or write command (see Section 7.3.1 on page 197). ■ Incoming data has been discarded since no BFS was included (see Section 7.3.1 on page 197). ■ Invalid BCC in a read or write command (see Section 7.3.1 on page 197). ■ Invalid address in a read or write command (see Section 7.3.1 on page 197). ■ Invalid data length in a read or write command (see Section 7.3.1 on page 197). ■ An unknown error with the binary read/write command format has occurred. 	6
Repeated pattern of 3 slow orange flashes	The last shading table generation process failed. The flashing will stop when you successfully complete a generation process or you reset the camera.	7
Repeated pattern of 2 slow orange flashes	<p>One of the following errors is present:</p> <p>The maximum allowed line rate has been exceeded (see Section Section 4.3 on page 74).</p> <p>ExSync has not changed state for 5 seconds or longer. Check the cable and the ExSync generating device.</p>	8 (lowest)

Table 30: Camera Status Indicators

8.4 Troubleshooting Charts

The following pages contain several troubleshooting charts that can help you find the cause of problems users sometimes encounter. The charts assume that you are familiar with the camera's features and settings and with the settings for your frame grabber. If you are not, we suggest you review the manuals for your camera and frame grabber before you troubleshoot a problem.

8.4.1 No Image

Use this chart if you see no image at all when you attempt to capture an image with your frame grabber (in this situation, you will usually get a message from the frame grabber such as “time-out”). If you see a poor quality image, a completely black image, or a completely white image, use the chart in Section 8.4.2 on [page 211](#).

Before making or breaking any camera connections, always switch off power to the system (camera and host PC).

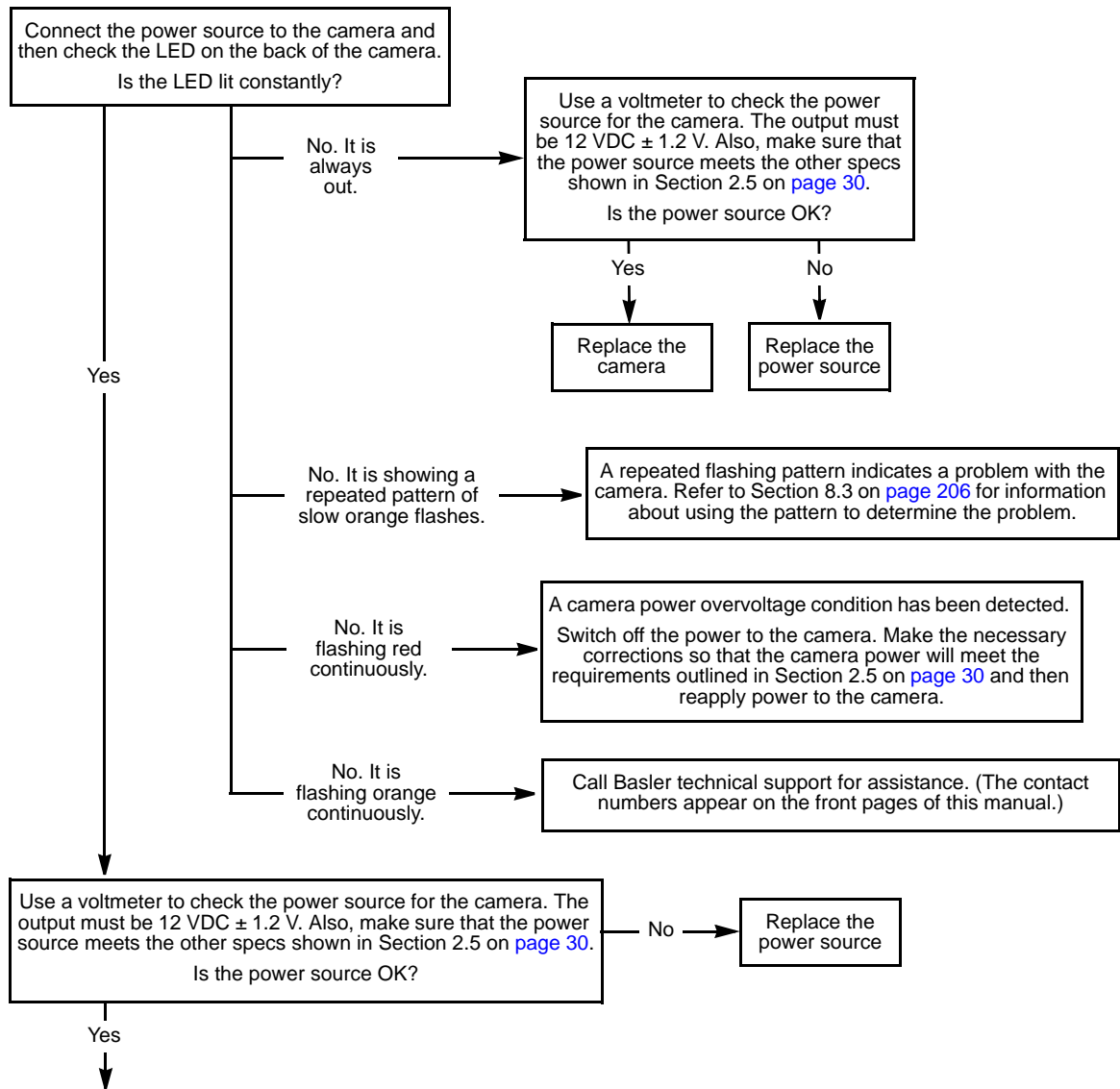

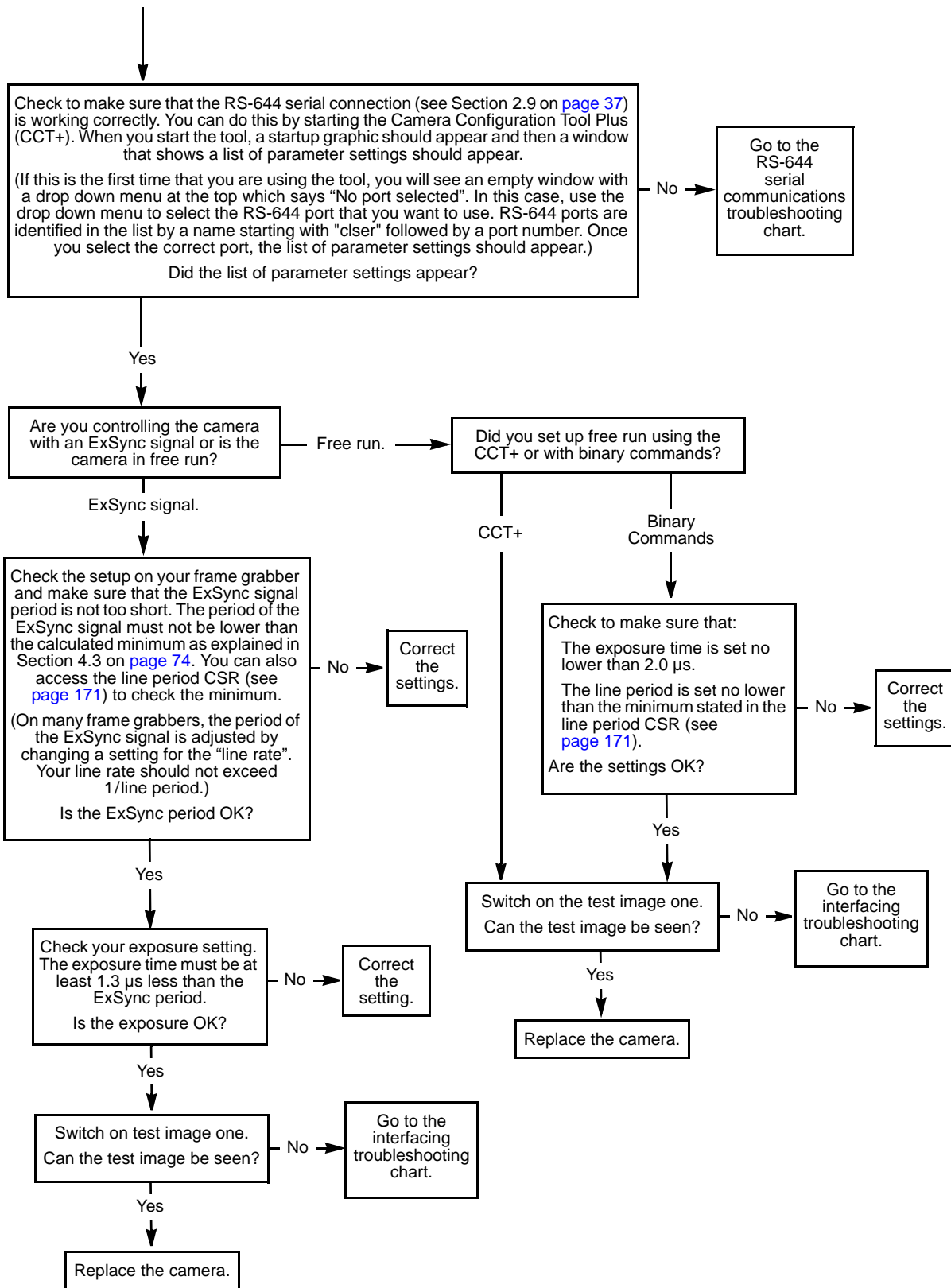

8.4.2 Poor Quality Image

Use this chart if the image is poor quality, is completely white, or is completely black. If you get no image at all when you attempt to capture an image with the frame grabber, use the chart that appears in Section 8.4.1 on [page 209](#).

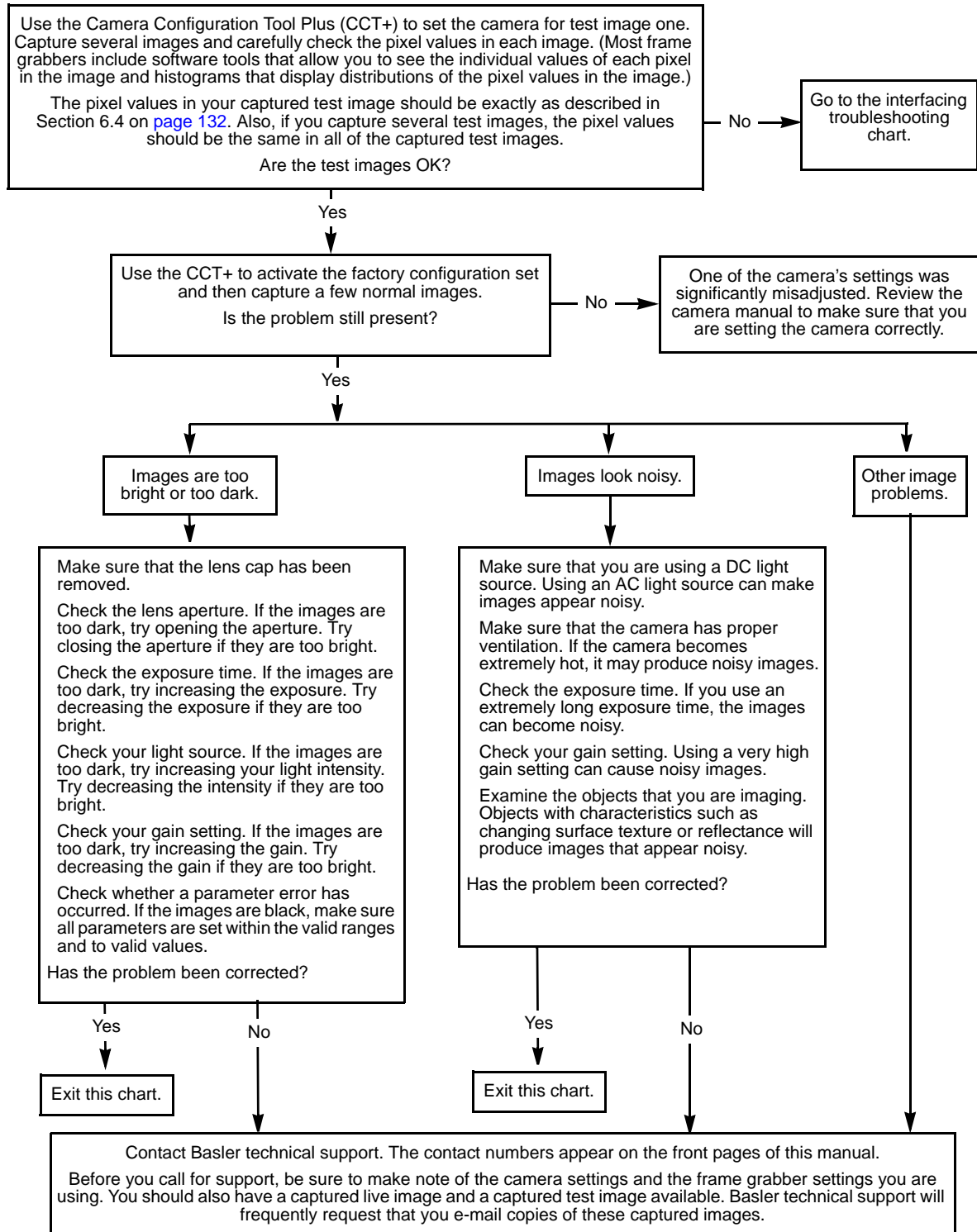

8.4.3 Interfacing

Use the interfacing troubleshooting chart if you think that there is a problem with the cables between your devices or if you have been directed here from another chart.

Before making or breaking any camera connections, always switch off power to the system (camera and host PC).

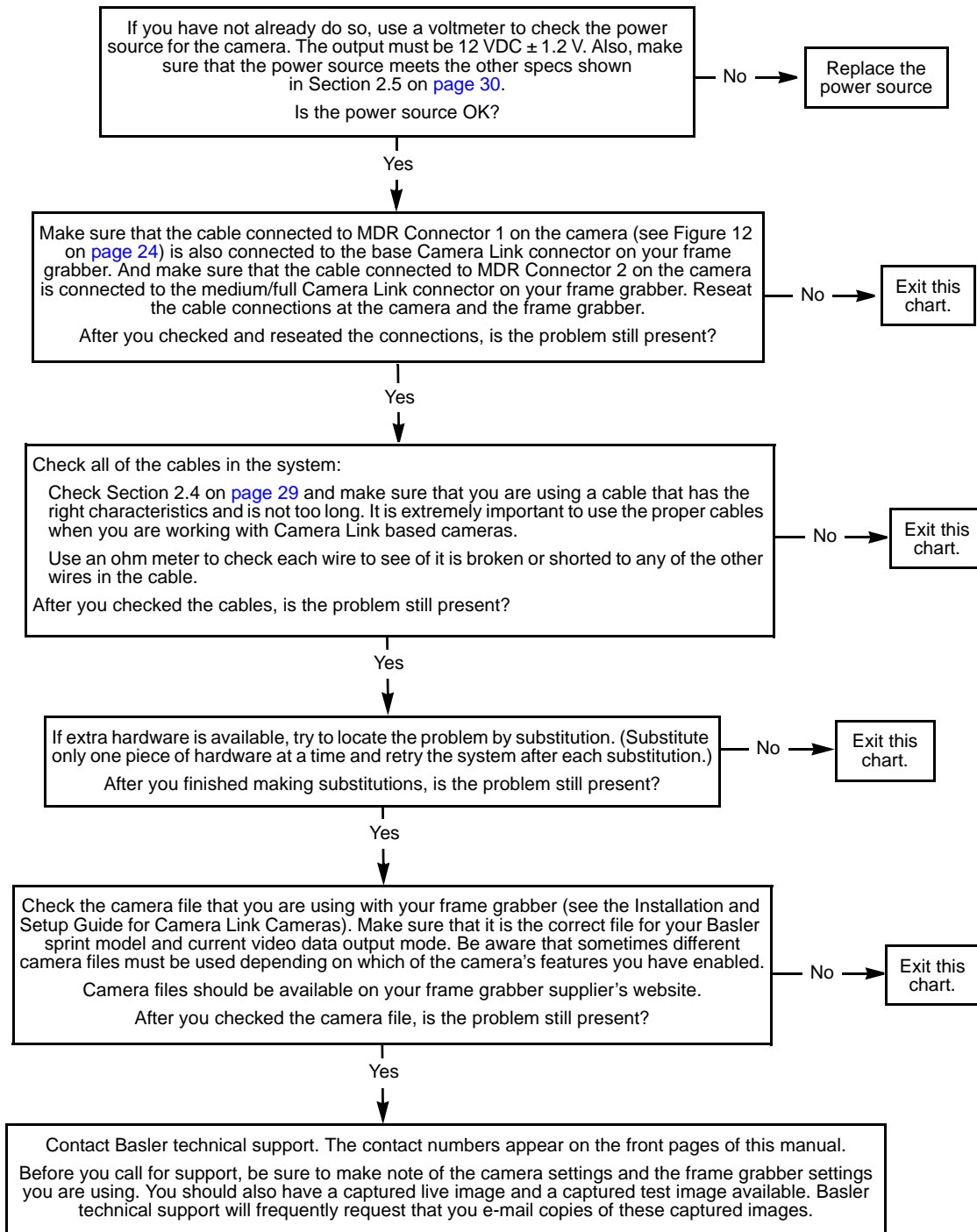

8.4.4 RS-644 Serial Communication

Use the serial communication troubleshooting charts if you think that there is a problem with RS-644 serial communication or if you have been directed here from another chart.

Before making or breaking any camera connections, always switch off power to the system (camera and host PC).

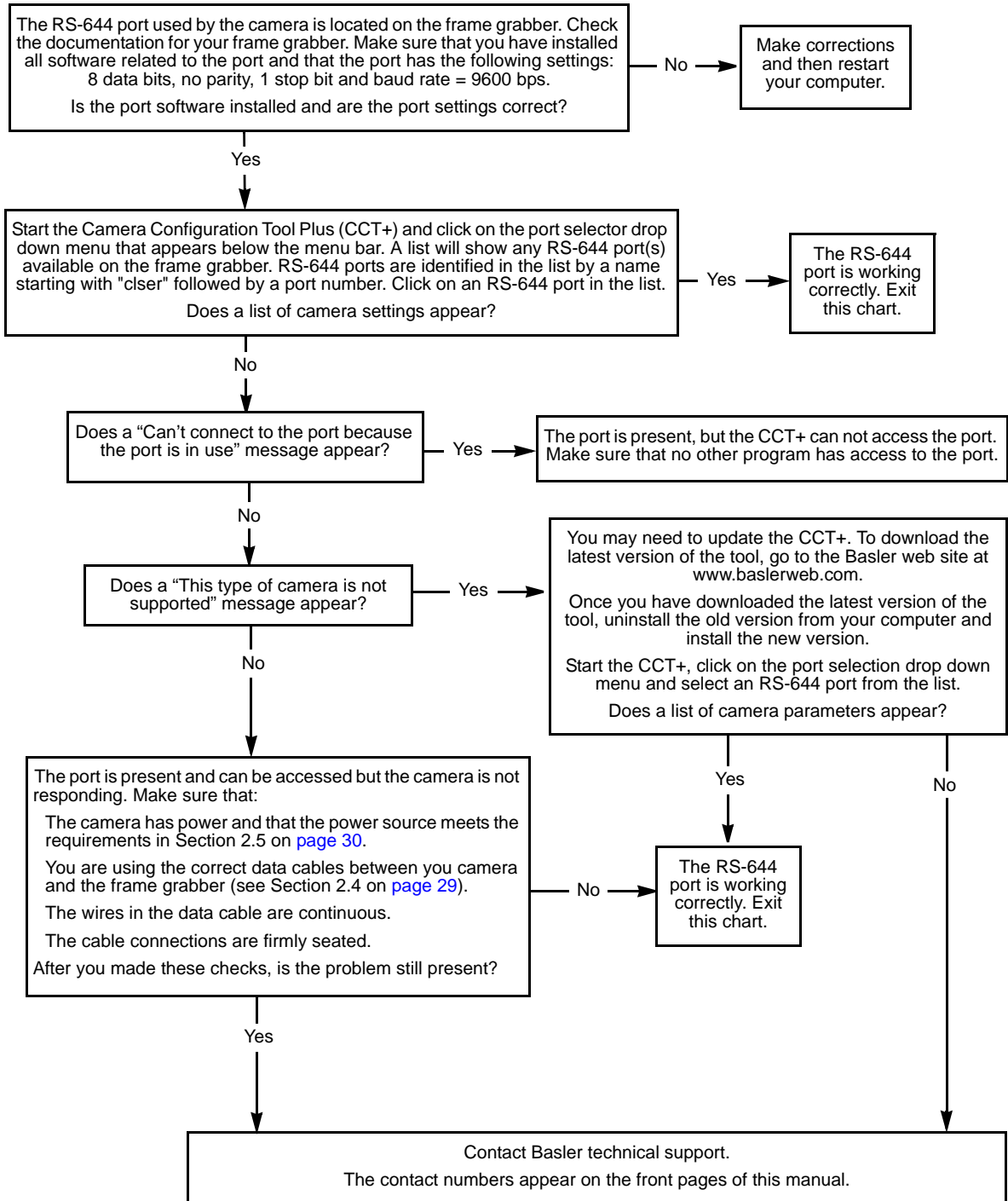

8.4.5 Before Calling Basler Technical Support

To help you as quickly and efficiently as possible when you have a problem with a Basler camera, it is important that you collect several pieces of information before you contact Basler technical support.

Copy the form that appears on this and the next page (or download it from the support section of www.baslerweb.com), fill it out, and fax the pages to your local dealer or to your nearest Basler support center. Or, you can write an e-mail listing the requested pieces of information and with the requested files attached. Our technical support contact numbers are shown in the title pages of this manual.

- 1 The camera's product ID: _____
- 2 The camera's serial number: _____
- 3 The operating system: _____
- 4 Frame grabber that you use with the camera: _____
- 5 CCT+ version that you use with the camera: _____
- 6 Describe the problem in as much detail as possible:
(If you need more space, use an extra sheet of paper.)

- 7 If known, what's the cause of the problem?

- 8 When did the problem occur?
 - After start. While running.
 - After a certain action (e.g., a change of parameters):

- 9 How often did/does the problem occur?
 - Once. Every time.
 - Regularly when:

 - Occasionally when:

10 How severe is the problem?

Camera can still be used.

Camera can be used after I take this action:

Camera can no longer be used.

11 Did your application ever run without problems?

Yes

No

12 Parameter set

It is very important for Basler technical support to get a copy of the exact camera parameters that you were using when the problem occurred.

To make a copy of the parameters, start the CCT+, select the File menu, and click Dump Current Settings to File. Send the generated file to Basler technical support.

If you cannot access the camera, please try to state the following parameter settings:

Video data output mode:

Exposure time control mode:

Exposure time:

Gain:

Offset:

Frame rate:

13 Live image/test image

If you are having an image problem, try to generate and save live images that show the problem. Also generate and save test images. Please save the images in BMP format, zip them, and send them to Basler technical support.

Revision History

Doc. ID Number	Date	Changes
AW00016201000	5 Dec 2006	Draft version for review only.
AW00016202000	1 Feb 2007	Preliminary version. Applies to prototypes only.
AW00016203000	11 Jul 2007	First release covering production cameras.
AW00016204000	25 Oct 2007	<p>Updated the camera version ID number stated in Section 1.1 on page 1.</p> <p>Updated the specification tables in Section 1.2 on page 2.</p> <p>Updated the warranty precautions on page 22.</p> <p>Added information about the switchable Camera Link clock speed to Section 2.8.4 on page 35.</p> <p>Added information about a new dual line acquisition mode to Section 3.1 on page 39 and Section 3.3 on page 41.</p> <p>Updated the line valid delay values in Table 12 on page 91, Table 15 on page 98, and Table 19 on page 107.</p> <p>Updated the description of the line stamp feature in Section 6.5 on page 136.</p> <p>Updated the line contrast formula on page 140.</p> <p>Updated the descriptions of the microcontroller firmware version and FPGA firmware version inquiry registers on page 154.</p> <p>Added the description of the Camera Link clock speed control and status register on page 166.</p>
AW00016205000	8 Jan 2008	<p>Removed the section of the manual that describes camera installation. The installation procedure is now available as a separate document.</p> <p>Updated the camera version ID number stated in Section 1.1 on page 1.</p> <p>Updated the specification tables in Section 1.2 to include new 2k and 4k camera models.</p> <p>Added Section 1.3 on page 5, which describes the available lens adapters.</p> <p>Updated Section 2.1 on page 24 and Section 2.2.3 on page 27 to show the connectors available on the new camera models.</p> <p>Updated Section 2.6 on page 31 and Section 2.8.4 on page 35 to describe the Camera Link configuration available on the new camera models.</p> <p>Updated Section 3 on page 39 and Section 3.3 on page 41 to clarify the line acquisition modes available on each camera model.</p> <p>Corrected the description of Vertical Binning Line Acquisition mode in Section 3.4 on page 49 and the description of the horizontal binning feature in Section 3.8 on page 59.</p> <p>Updated the exposure start delays listed in Table 9 on page 70.</p> <p>Updated the formulas and descriptions throughout Section 4.3 on page 74 to include information relevant to the new 2k and 4k camera models.</p> <p>(Continued on the next page.)</p>

Doc. ID Number	Date	Changes
		<p>(Continued from the previous page.)</p> <p>Added Table 11 on page 86, which describes the video data output modes available on each model.</p> <p>Updated Figure 35 on page 91 through Figure 40 on page 111 to reflect the sensor sizes available on the new camera models.</p> <p>Updated Table 13 on page 93, Table 15 on page 98, and Table 19 on page 107 to reflect minor timing changes made with the new camera models.</p> <p>Updated Section 6.1.1 on page 115 to reflect a change in the minimum allowed gain setting.</p> <p>Updated Section 6.2 on page 118 to reflect the sensor sizes available in the new camera models.</p> <p>Added Section 6.6 on page 141 and the register information on page 183, page 184, and page 185 to describe the new lookup table feature.</p>

Doc. ID Number	Date	Changes
AW00016206000	12 Sep 2008	<p>Integrated the 8k camera models.</p> <p>Updated contact addresses and phone numbers.</p> <p>Updated the camera version ID number in Section 1.1 on page 1.</p> <p>Replaced "input power" by "camera power" in Section 1.7 on page 20, Section 2 on page 23, Section 6 on page 115, Section 7.2.1.1 on page 158, and Section 8.4.1 on page 209.</p> <p>Modified the labelling of the y axis of Figure 4 in Section 1.4 on page 10.</p> <p>Updated the minimum high time of the ExSync signal in Section 2.7.2 on page 33.</p> <p>Corrected the recommendations of when to use Line A First and Line B First modes in Section 3.3 on page 41.</p> <p>Updated the calculations of the actual exposure time with ExSync edge controlled mode and of the max. allowed programmed exposure time with ExSync programmable mode in Section 4.1.3 on page 69.</p> <p>Added a note about a decreased maximum line rate for the spA2048-140km when operated with 8 tap output at 80:Mhz in Section 4.3 on page 74 and Section 5.1 on page 85.</p> <p>Updated the calculation for the max. allowed line rate according to formula 1 in Section 4.3.2 on page 80.</p> <p>Added Section 4.3.4 on page 82: "Camera Settings for the Maximum Specified Line Rate".</p> <p>Updated and added line valid delay data in Section 5.2.1.2 on page 93, Section 5.2.2.2 on page 102, and Section 5.2.3.2 on page 112.</p> <p>Removed the incorrect information that the line counter is reset whenever the stamp feature is disabled from Section 6.5 on page 136.</p> <p>Added note about data depth of the transmitted data when using the lookup table feature with a 10 bit or 12 bit video data output mode in Section 6.6 on page 141.</p> <p>Added the name "FactorySet" in Section 6.12 on page 149.</p> <p>Added note not to use the CCT+ in demo mode in Section 7.1 on page 156.</p> <p>Removed the Microcontroller Firmware Version Inquiry, the FPGA Firmware Version Inquiry, and the FPGA Configuration Version Inquiry registers in Section 7.2.1.1 on page 158.</p> <p>Added the Firmware Version Inquiry register in Section 7.2.1.1 on page 158.</p> <p>Additions and corrections in the Configuration Set and Shading Values CSRs in Section 7.2.3.4 on page 194:</p> <ul style="list-style-type: none"> ■ Added "Erase" and corrected the enumeration for "Activate" in the Control fields. ■ Corrected the value for "This is an activated file" in the Info fields. ■ Added the allowed file names to the File Name fields. <p>Updated the minimum difference between the exposure time and the ExSync period in Section 8.4.1 on page 209.</p> <p>Minor corrections and modification throughout the manual.</p>

Doc. ID Number	Date	Changes
AW00016207000	18 Dec 2008	<p>Corrected the tolerances for the distance between the CMOS sensor and the front surface of the lens adapter mount for 2k and 4k cameras in Figure 5 on page 12 and Figure 6 on page 13.</p> <p>Improved the indications of the reference planes for the camera housings in Figure 5 on page 12 through Figure 7 on page 14 and Figure 9 on page 16 through Figure 11 on page 18.</p> <p>Corrected the minimum gain value in Section 7.2.2.1 on page 164.</p> <p>Expanded Section 8.1 on page 205 and added Section 8.2 on page 205 describing how to obtain an RMA number.</p>
AW00016208000	09 Apr 2009	<p>Added references to the table with parameter settings for achieving the maximum line rates in Section 1.2 on page 2.</p> <p>Added information about the set screws for attaching lens mounts in Figure 5 on page 12 and Figure 9 on page 16.</p> <p>Corrected the minimum high time for the ExSync signal in level controlled mode in Section 4.1.3 on page 69.</p> <p>Changed the jitter related to exposure times to 100 ns in Section 4.1.3 on page 69.</p> <p>Modified the explanation related to using a too long exposure time for ExSync programmable mode in Section 4.1.3 on page 69.</p> <p>Added advice for increasing the line rate in Section 4.3.3 on page 81.</p> <p>Indicated on page 161 that a black image results if a parameter error has occurred.</p> <p>Corrected the minimum gain value in the example in Section 7.2.2.1 on page 164.</p> <p>Added the parameter error to Section 8.4.2 on page 211.</p>

Feedback

Your feedback will help us improve our documentation. Please click the link below to access an online feedback form. Your input is greatly appreciated.

<http://www.baslerweb.com/umfrage/survey.html>

Index

Numerics

2 tap video data output modes	88
4 tap video data output modes	96
8 tap video data output modes	105

A

absolute values	165
acquisition modes	
see line acquisition modes	
AOI	
see area of interest	
area of interest	77, 118
segment	77
area of interest length control and status register	177
area of interest starting pixel control and status register	176

B

base Camera Link configuration	24, 31
binary command protocol status inquiry register	163
binary read/write commands	196
binning, horizontal	59
bulk data	188
bulk data registers	157, 188

C

cabling	29
calculations, design	63
camera configuration tool	156
Camera Link cable	29
Camera Link clock speed	35
Camera Link clock speed control and status register	166
Camera Link implementation	31
camera power	30
camera reset control and status register	186
camera status inquiry register	161
camera version inquiry register	159
CCT+	156
cleaning the camera and sensor	22

cleaning the sensor	22
clock speed, Camera Link	35
code samples	204
configuration set control and status register	194
configuration sets	
defined	149
saving	151
configuration tool	156
connectors	
locations	24
pin assignments	25
pin numbering	27
types	28
control and status registers	157, 164

D

data valid bit	34
design calculations	63
design recommendations, system	61
dimensions	
2k and 4k cameras	12
2k and 8k cameras	11
8k cameras	15, 16
DSNU shading correction	121
dual line acquisition modes	41
dust	21

E

edge controlled exposure time control mode	67, 71
eight tap video data output modes	105
environmental requirements	19
exposure start delay	70
exposure time control and status register	169
exposure time control mode control and status register	168
exposure time control modes	
edge controlled	67, 71
level controlled	68
programmable	68, 72
ExSync signal	33, 67

F

firmware version inquiry register	160
four tap video data output modes	96
FPGA status inquiry register	162
free run	71

G

gain	115
gain control and status register	173

H

heat dissipation	19
helical mount	
UNIFOOC 100/95/_/V-Basler	5, 6
UNIFOOC 76	8
horizontal binning	59
horizontal binning control and status register	168
housing size	
2k cameras	2
4k cameras	3
8k cameras	4
humidity	19

I

imaging sensor temperature inquiry register	163
input signals	
ExSync	33
serial to camera	33
inquiry registers	157, 158

L

LED	206
lens adapter	8
2k cameras	2
4k cameras	3
8k cameras	4
lens adapter (2k, 4k cameras)	15
lens mount	
M58 x 0.75/_/V-Basler	5, 8
level controlled exposure time control mode	68
line acquisition mode control and status register	167

line acquisition modes	39
dual line	41
line averaging	57
single line (max 70 kHz)	40
time delayed line averaging	58
time delayed line summing	51
vertical binning	49
line averaging acquisition mode	57
line period	
conversion to line rate	81
line period control and status register ..	171
line rate	
conversion to line period	81
maximum allowed	74
maximum specified	82
line stamp	136
line stamp high pixel threshold control and status register	182
line stamp low pixel limit control and status register	181
line stamp mode control and status register	180
line valid bit	34
line valid delay	91–114
lookup table	141
lookup table index control and status register	184
lookup table mode control and status register	183
lookup table value control and status register	185

M

maximum allowed line rate	74
maximum specified line rate	82
medium/full Camera Link configuration	24, 31
minimum line rate	
2k cameras	2
4k cameras	3
8k cameras	4
model info inquiry register	158
mounting holes	
2k and 4k cameras	11
8k cameras	15

O

offset	116
offset control and status register	174
operating recommendations	61
output signals	
Camera Link clock	35
data valid bit	34
ExSync	67
line valid bit	34
pixel data bits	34
serial to frame grabber	36
overtemperature	146
overvoltage protection	145

P

parameter sets, saving	149
pin assignments	25
pin numbering	27
pixel data bits	34
pixel data sequence	
see video data sequence	89
pixel size	2, 3, 4
power	30
power cable	29
precautions	20
PRNU shading correction	121
product ID inquiry register	159
programmable exposure time control mode	68, 72

R

raw values	164
read/write commands	196
recommendations	
operating	61
system design	61
registers	157
reset	148
return material authorization	205
RMA number	205
RS-644 serial communication	37

S

sample code	204
saving camera parameter sets	149

sensor

cleaning	22
line location (2k, 4k cameras)	14
line location (8k cameras)	18
positioning accuracy (2k and 4k cameras)	13
positioning accuracy (8k cameras) ...	17
size	2, 3, 4
serial communication	37
serial communication control and status register	187
serial number inquiry register	159
serial to camera input signal	33
serial to frame grabber output signal	36
shading correction	121
shading mode control and status register	178
shading value generate control and status register	178
shading values control and status register	195
single line (max 70 kHz) acquisition mode	40
specifications	2
spectral response	10
status checks	148
synchronization signal	
see ExSync signal	67

T

technical support	205
temperature	19
test image mode control and status register	179
test images	132
time delayed line averaging acquisition mode	58
time delayed line summing acquisition mode	51
troubleshooting	208
two tap video data output modes	88

U

undervoltage protection	145
-------------------------------	-----

V

vendor info inquiry register	158
ventilation	19
vertical binning acquisition mode	49
video data output mode control and status register	166
video data output modes	85
video data sequence	
2 tap output modes	89
4 tap output modes	97
8 tap output modes	105

W

weight	
2k cameras	2
4k cameras	3
8k cameras	4